

H7625B, H7626B, H7635B, C H7636B, H7655B, H7656B

DUCT-MOUNT AND OUTDOOR-MOUNT HUMIDITY/ TEMPERATURE SENSORS

INSTALLATION INSTRUCTIONS

APPLICATION

The H76XXB Duct-Mount and H76XXC Outdoor-Mount Humidity/Temperature Sensors are universal Relative Humidity transmitters that can be powered with either a +18 to 40 Vdc or 24 Vac supply. The devices are half wave rectified. The transmitter also includes either a 20K ohm NTC thermistor or a 1K platinum PTC (compatible with the T775) for optional temperature use.

The humidity sensors are designed with a field selectable 4 to 20 mA, 0 to 5 Vdc, or 0 to 10 Vdc output signal equivalent to 0 to 100% RH. All units are shipped from the factory with a default setting to accept AC power with three-wire, 0 to 10 Vdc output.

INSTALLATION

When Installing this Product...

1. Read these instructions carefully. Failure to follow them could damage the product or cause a hazardous condition.
2. Check ratings given in instructions and on the product to ensure the product is suitable for your application.
3. Installer must be a trained, experienced service technician.
4. After installation is complete, check out product operation as provided in these instructions.



CAUTION

Electrical Shock or Equipment Damage Hazard.

Can shock individuals or short equipment circuitry.

Disconnect power supply before installation.



CAUTION

Equipment Damage Hazard.

Improper wiring can damage the sensor beyond repair.

Follow the wiring instructions carefully.

Mounting

The method of mounting depends on the particular sensor application. The following procedures include outdoor and duct applications. Also refer to the instructions for the electronic control.

Duct mounting Configuration

The H7625B, H7626B, H7635B, H7636B, H7655B and H7656B can be mounted in a duct to sense humidity and temperature.

IMPORTANT

Select a location to expose sensor to average duct humidity and temperature. Avoid locations where stratification can cause sensing errors.

NOTES:

- Knockouts allow 1/2 in. conduit connection. To avoid damaging board during installation, the cover can be detached completely.
 - Carefully remove wire plug from board.
 - Set the cover aside.
1. Drill a 3/4" diameter hole in the duct where the transmitter is to be mounted.
 2. Insert the stainless steel probe into the hole until the foam is in direct contact with the duct.
 3. Attach the transmitter to the duct using the supplied #8 X 3/4" self-tapping screws.
 4. Remove the cover and install your conduit connector or watertight fitting. The outer ring is used when using a 1/2" NPT conduit fitting.
 5. After wiring the unit, place the cover back on and gently turn it until it is tight.

Outdoor Mounting Configuration

The H7635C senses outdoor air humidity and temperature. Mount this control where it can sense average outdoor air humidity and temperature. Normally, the north side of a building provides a suitable location.

NOTES:

- H7635C is weatherproof for outdoor use. Knockouts allow 1/2 in. conduit connection.
- To avoid damaging board during installation, the cover can be detached completely.
- Carefully remove wire plug from board.
- Set the cover aside.



The transmitter should be mounted under an eave, shield, or in an area out of the elements or direct sunlight. The aluminum tube should point down when mounting the outside transmitter.

Refer to Figure 1 for proper mounting position.

1. Place the unit where it is to be mounted with the cover facing out.
2. Attach the unit with the supplied #8 X 3/4" self-tapping screws.
3. Remove the cover and install your conduit connector, watertight fitting or 1/2" vent plug. The outer ring is used when using a 1/2" NPT conduit fitting.
4. After wiring the unit, place the cover back on and turn it until it is tight.

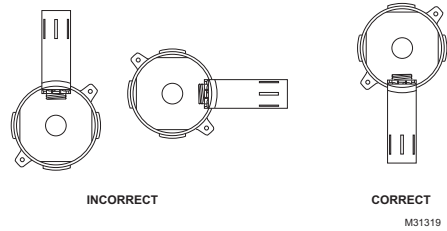

Fig. 1. Typical sensor location.

Output Settings

The humidity output signal can be adjusted for 0-5Vdc, 0-10 Vdc or 4-20 mA using the switch block. Switches 6, 7, and 8 are used to set the output.

NOTE: Refer Fig. 2 for switch settings.

Table 1. Controller Compatibility and Output Settings.

Controller	Required Sensor Output Setting	LONSPEC™ Setting
W7750, W7760, W7761	4-20 mA	C7600C
W7750B,C W7760C, W7753, W7760	0-10 Vdc (default)	H7621/31
T7350, XL50, XL100, XL500 XF Modules, XFL	0-10 Vdc (default)	n/a
Non-Honeywell	0-5 Vdc	n/a

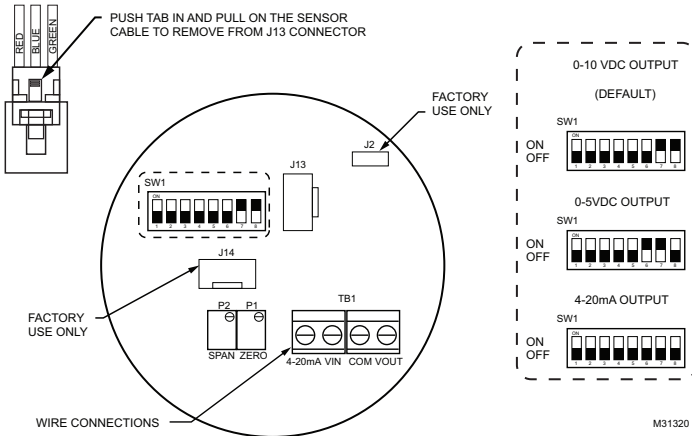

Fig. 2. DIP switch and Wire Connection locations.

REVERSE ACTING OUTPUT

The output can be changed to reverse acting mode. The output range stays the same but the corresponding RH value is opposite.

Example: Direct Acting (DA) (Default)

0-10V output mode
 0V = 0% RH and 10V = 100% RH

Reverse Acting (RA)

0-10V output mode,
 0V = 100% and 10V = 0%

To change the transmitter to reverse acting or back to direct acting, set switch 4 ON to put the unit in setup mode. After switch 4 is on, switch 2 will put the unit in direct/reverse acting mode. When switch 2 is set to ON, the output can be used to show if the unit is in direct or reverse acting mode. For direct acting the output will be 1V for 0-5V, 2V for 0-10V, and 7.2mA for 4-20mA. For reverse acting the output will be 4V for 0-5V, 8V for 0-10V, and 16.8mA for 4-20mA.

With switches 2 and 4 ON, each time switch 5 is set to ON the output will change to reverse acting or direct acting.

To reset the unit to the default setting, toggle both switches 5 and 6 ON then OFF while both switches 2 and 4 are ON.

When all calibration is completed, remember to place the switches back into the positions that correspond to the output needed as shown in Figure 3.

WIRING

A 16 to 22 AWG shielded cable is recommended for all transmitters. Twisted pair may be used for 2-wire current output transmitters. The connections to the temperature sensor should be made with wire nuts or crimp-style connectors. Refer to Figure 3 for wiring diagrams.

CAUTION

Never connect or disconnect wiring with power applied.

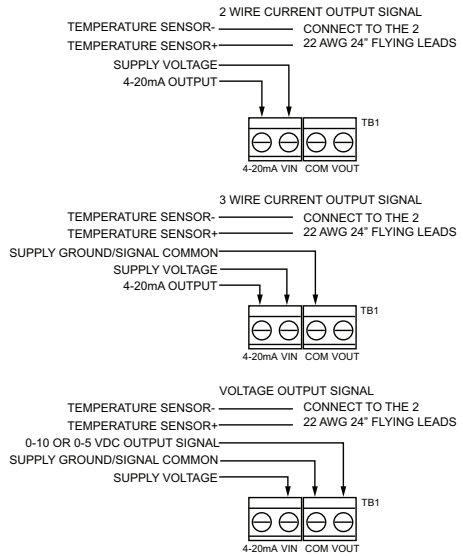

Fig. 3. Wiring Diagrams

CAUTION

It is recommended that you use an isolated UL-listed class 2 transformer when powering the unit with 24 VAC. Failure to wire the devices with the correct polarity when sharing transformers may result in damage to any device powered by the shared transformer.

IMPORTANT

When using shielded cable, ground the shield only at the controller end (see Fig. 4). Grounding both ends can cause a ground loop.

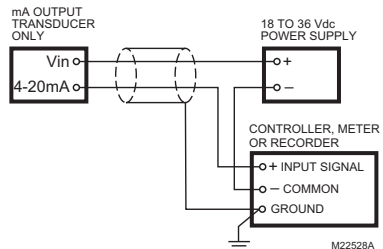
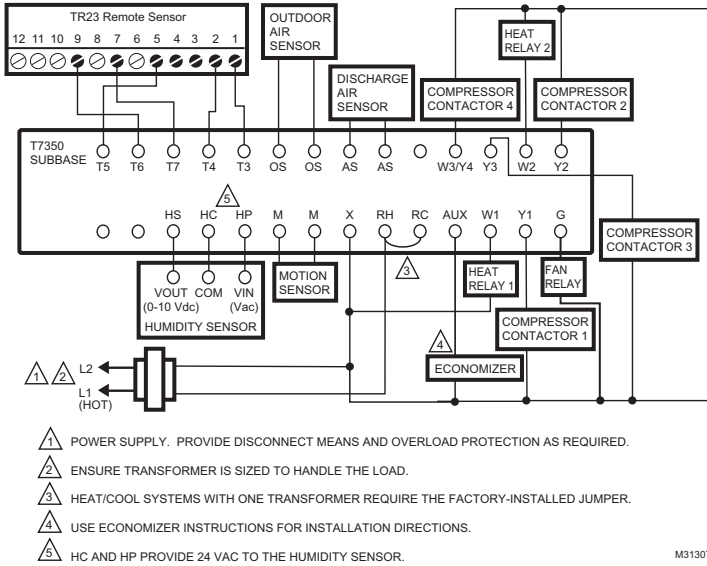
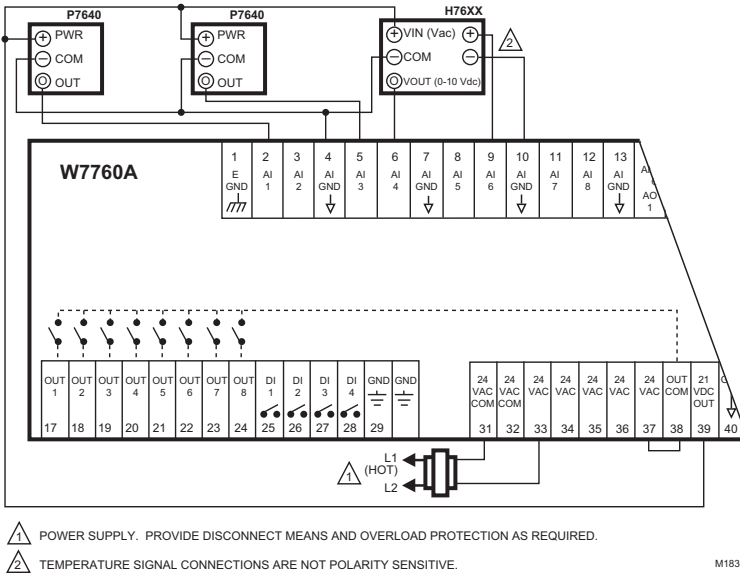

Fig. 4. Typical wiring diagram for transducer with two-wire mA output with external DC power supply.



M31307

Fig. 5. Humidity Sensor (0-10 Vdc output) wiring with T7350 (use with RH/Temperature combination T7350 units only).



M18302C

Fig. 6. Typical wiring diagram for 5-wire temperature/humidity sensor with Vdc output (used with the XL15A controller).

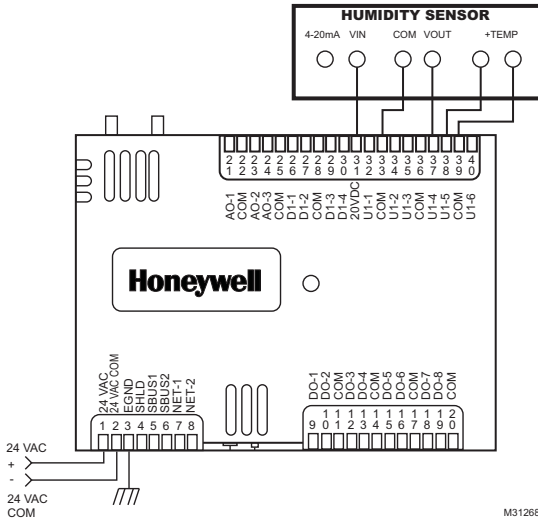

Fig. 7. Typical wiring diagram for 5-wire temperature/humidity sensor with Vdc output (used with the Spyder controller).

CHECKOUT

CAUTION

Equipment Damage Hazard.
Can short electric circuitry.

- Never connect 120 Vac to the transducer.
- Connect only DC voltage to a transducer intended for DC supply.

NOTE: Use laboratory quality meters and gauges for applications requiring a high degree of accuracy.

1. Verify that the transducer is mounted in the correct position.
2. Verify appropriate input signal and voltage supply.
3. Verify appropriate configuration range.

Converting Output Signal to Percent RH

4 to 20mA Signal

$((\text{mA signal}) - 4) / 0.16 = \text{percent RH}$
Example: 12mA output signal
 $(12 - 4) / 0.16 = 50\% \text{ RH}$

0 to 5 Vdc Signal

$(\text{VDC signal}) / 0.05 = \text{percent RH}$
Example: 1.25vdc output signal
 $1.25 / 0.05 = 25\% \text{ RH}$

0 to 10 Vdc Signal

$(\text{VDC signal}) / 0.10 = \text{percent RH}$
Example: 7.50vdc output signal
 $7.50 / 0.10 = 75\% \text{ RH}$

Table 2. Troubleshooting.

Problem	Items to Check
No reading	<ul style="list-style-type: none"> • Verify correct supply voltage at the power terminal blocks. • Verify correct wiring configuration and DIP switch settings per Figures 2 and 3. • Verify that terminal screws are connected tightly with all wires firmly in place.
Erratic readings	<ul style="list-style-type: none"> • Verify all wires are terminated properly. • Ensure that there is no condensation on the board. • Verify clean input power. In areas of high RF interference or noise, shielded cable can be necessary to stabilize signal.
Inaccurate readings	<ul style="list-style-type: none"> • If you suspect that the transmitter is not reading within the specified tolerance, please contact the factory for further assistance

APPENDIX

RH Test and Configuration DIP Switch Settings (Table 3)

IMPORTANT

- Only adjust these switches for troubleshooting or recalibrating the sensor.
(Adjustment is not normally necessary.)

Test mode will make the transmitter output a fixed 0%, 50%, or 100% value. The sensor will not affect the transmitter output. This is used for troubleshooting or testing only.

Switches 1, 2, and 3 are used for test mode. The output will be a fixed 0%, 50%, or 100% signal that corresponds to the output selected with switches 6, 7, and 8. Refer to Figure 4 for switch settings.

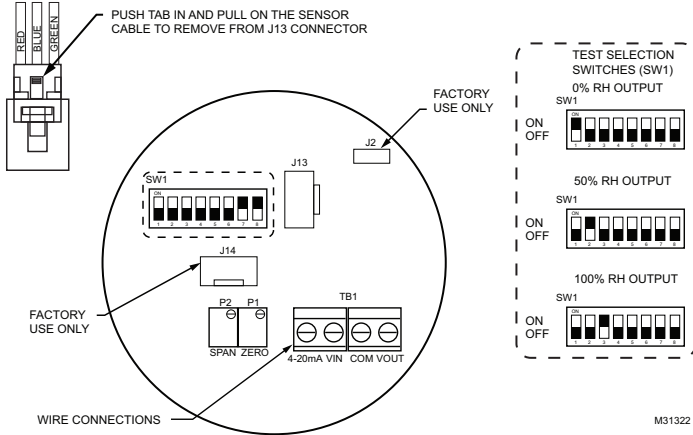

Fig. 8. Settings

Table 3. Test and Calibration Settings (8-Switch Block).

Setting	1	2	3	4	5	6	7	8
4-20mA Output	—	—	—	—	—	—	—	—
0-5 VDC Output	—	—	—	—	—	On	On	—
0-10 VDC Output	—	—	—	—	—	—	On	On
0% RH Output	On	—	—	—	—	—	—	—
50% RH Output	—	On	—	—	—	—	—	—
100% RH Output	—	—	On	—	—	—	—	—
Increment RH Output	—	—	—	On**	On	—	—	—
Decrement RH Output	—	—	—	On**	—	On	—	—
Reset to Original Calibration	—	—	—	On**	On	On	—	—
Reverse or Direct Acting	—	On	—	On**	On	—	—	—
Reverse or Direct Acting Reset	—	On	—	On**	On	On	—	—

* = Switch setting does not affect output
 ** = This switch needs to be activated first
 — = Indicates OFF

CALIBRATION

NOTE: This is only a single point calibration. All transmitters are factory calibrated to meet/exceed published specifications. Field adjustment should not be necessary.

The dipswitch allows the user to calibrate the sensor through the software. Setting switch 4 ON will put the transmitter into setup mode allowing the increment and decrement to work. Once in setup mode, the output will change to 50% (2.5V for 0-5V, 5V for 0-10V, 12mA for 4-20mA). Each increment or decrement step will cause the output to change by 0.1V for 0-5V, 0.2V for 0-10V, and 0.32mA for 4-20mA in setup mode. This can be used to show the user how far offset the transmitter is. To see the starting point again set switch 1 ON. This will show the 50% output again. When the unit is out of setup mode the output will go back to RH output.

Increment RH Output

This will shift the RH output linearly up in 0.5% steps. Switch 4 must be set to ON first. After switch 4 is on, each time switch 5 is set ON the RH output will increase by 0.5%. The increase goes into effect each time switch 5 is set to ON.

Decrement RH Output

This will shift the RH output linearly down in 0.5% steps. Switch 4 must be set to ON first. After switch 4 is on, each time switch 6 is set ON the RH output will decrease by 0.5%. The decrease goes into effect each time switch 6 is set to ON.

Reset RH Output

This will reset the RH output back to the original calibration. Switch 4 must be set to ON first. After switch 4 is on, toggle switches 5 and 6 ON then OFF. After 5 and 6 are OFF slide switch 4 OFF.

When all calibration is completed, remember to place the switches back into the positions that correspond to the output needed as shown in Figure 3.

H7625B, H7626B, H7635B, C H7636B, H7655B, H7656B

LonSpec™ is a trademark of Echelon® Corporation.

Automation and Control Solutions

Honeywell International Inc.
1985 Douglas Drive North
Golden Valley, MN 55422

Honeywell Limited-Honeywell Limitée
35 Dynamic Drive
Toronto, Ontario M1V 4Z9
customer.honeywell.com

® U.S. Registered Trademark
© 2010 Honeywell International Inc.
62-0330—01 E.K. Rev. 03-10
Printed in U.S.A.

Honeywell