



CYBERNETIK TECHNOLOGIES PVT LTD

GAT NO.365,URWADE,MUTHA ROAD,MULSHI.
 PUNE:412108
 Phone. 020-39152307

PROJECT CODE : HA-382
 Project description HA-382 VOLVO FRANCE
 PROCESS AREA :

Manufacturer (company) CYBERNETIK TECHNOLOGIES PVT LTD
 Path D:\SHITAL PROJECTS-11-12\HA-381 VOLVO FRANCE\MASTER 1-6-12\HA 382 VOLVO FRANCE.elk
 Project name HA 382 VOLVO FRANCE
 make CTPL
 Type AUTOMATION
 Place of installation +ET1

Drawn by SHITAL

Number of pages 147

DOCUMENT ID : CY/DD/R/07

REV : 00



CYBERNETIK TECHNOLOGIES
 PVT.LTD, PUNE

| | Date | Name |
|----------|------|--------|
| DRAWN | | SHITAL |
| CHECKED | | |
| APPROVED | | |

| PROJECT DESCRIPTION |
|---------------------|
| HA-382 VOLVO FRANCE |

| TITLE |
|-----------|
| COVERPAGE |

| | |
|-------------------|---------------|
| PROJECT CODE:- | HA-382 |
| DRAWING NUMBER :- | |
| Page | 1 |
| Pages | 147 |

| I/O LIST FOR HA-381 VOLVO JAPAN | | | | | | | | |
|--|-------|-------------------------|--------------|----------|--------|-------------------|--------|------|
| CPU-S7 315 PN/DP+32 DI+16 DI+32 DO+8DO | | | | | | | | |
| S.N. | I/P | Description | Device | Tags | O/P | Description | Device | Tags |
| 1 | I:0/0 | AUTO/MANUAL | SELECTOR SW. | S3 | O:6/0 | RED | LAMP | H5 |
| 2 | I:0/1 | SYSTEM START | PUSH BUTTON | S4 | O:6/1 | YELLOW | LAMP | H6 |
| 3 | I:0/2 | SPARE | SPARE | | O:6/2 | GREEN | LAMP | H7 |
| 4 | I:0/3 | SPARE | SPARE | | O:6/3 | BUZZER | BUZZER | BZ1 |
| 5 | I:0/4 | ZONE -1 SAFETY I/P | CONTACT | K101/102 | O:6/4 | SYSTEM START LAMP | LAMP | H8 |
| 6 | I:0/5 | ZONE -2 SAFETY I/P | CONTACT | K103/104 | O:6/5 | SPARE | SPARE | |
| 7 | I:0/6 | ZONE -3 SAFETY I/P | CONTACT | K105/106 | O:6/6 | SPARE | SPARE | |
| 8 | I:0/7 | ZONE -4 SAFETY I/P | CONTACT | K107/108 | O:6/7 | SPARE | RELAY | RO1 |
| 9 | I:1/0 | SPARE | | | O:7/0 | SPARE | RELAY | RO2 |
| 10 | I:1/1 | SPARE | | | O:7/1 | SPARE | RELAY | RO3 |
| 11 | I:1/2 | ZONE-1 EMG STOP-1 | | | O:7/2 | SPARE | RELAY | RO4 |
| 12 | I:1/3 | ZONE-2 EMG STOP-2 | | | O:7/3 | SPARE | RELAY | RO5 |
| 13 | I:1/4 | ZONE-3 EMG STOP-3 | | | O:7/4 | SPARE | RELAY | RO6 |
| 14 | I:1/5 | ZONE-4 EMG STOP-4 | | | O:7/5 | SPARE | RELAY | RO7 |
| 15 | I:1/6 | SPARE | | | O:7/6 | SPARE | RELAY | RO8 |
| 16 | I:1/7 | SPARE | | | O:7/7 | SPARE | RELAY | RO9 |
| 17 | I:2/0 | ZONE-1 LIGHT CURTAIN -1 | | | O:8/0 | SPARE | RELAY | RO10 |
| 18 | I:2/1 | ZONE-1 LIGHT CURTAIN -2 | | | O:8/1 | SPARE | | |
| 19 | I:2/2 | ZONE-1 LIGHT CURTAIN -3 | | | O:8/2 | SPARE | | |
| 20 | I:2/3 | ZONE-1 LIGHT CURTAIN -4 | | | O:8/3 | SPARE | | |
| 21 | I:2/4 | ZONE-1 LIGHT CURTAIN -5 | | | O:8/4 | SPARE | | |
| 22 | I:2/5 | ZONE-3 LIGHT CURTAIN -1 | | | O:8/5 | SPARE | | |
| 23 | I:2/6 | ZONE-3 LIGHT CURTAIN -2 | | | O:8/6 | SPARE | | |
| 24 | I:2/7 | ZONE-3 LIGHT CURTAIN -3 | | | O:8/7 | SPARE | | |
| 25 | I:3/0 | ZONE-3 LIGHT CURTAIN -4 | | | O:9/0 | SPARE | | |
| 26 | I:3/1 | ZONE-3 LIGHT CURTAIN -5 | | | O:9/1 | SPARE | | |
| 27 | I:3/2 | SPARE | | | O:9/2 | SPARE | | |
| 28 | I:3/3 | SPARE | | | O:9/3 | SPARE | | |
| 29 | I:3/4 | SPARE | | | O:9/4 | SPARE | | |
| 30 | I:3/5 | SPARE | | | O:9/5 | SPARE | | |
| 31 | I:3/6 | SPARE | | | O:9/6 | SPARE | | |
| 32 | I:3/7 | SPARE | | | O:9/7 | SPARE | | |
| 33 | I:4/0 | SPARE | | | O:10/0 | SPARE | | |
| 34 | I:4/1 | SPARE | | | O:10/1 | SPARE | | |
| 35 | I:4/2 | SPARE | | | O:10/2 | SPARE | | |
| 36 | I:4/3 | SPARE | | | O:10/3 | SPARE | | |
| 37 | I:4/4 | SPARE | | | O:10/4 | SPARE | | |
| 38 | I:4/5 | SPARE | | | O:10/5 | SPARE | | |
| 39 | I:4/6 | SPARE | | | O:10/6 | SPARE | | |
| 40 | I:4/7 | SPARE | | | O:10/7 | SPARE | | |
| 41 | O:5/0 | SPARE | | | | | | |
| 42 | O:5/1 | SPARE | | | | | | |
| 43 | O:5/2 | SPARE | | | | | | |
| 44 | O:5/3 | SPARE | | | | | | |
| 45 | O:5/4 | SPARE | | | | | | |
| 46 | O:5/5 | SPARE | | | | | | |
| 47 | O:5/6 | SPARE | | | | | | |
| 48 | O:5/7 | SPARE | | | | | | |

DOCUMENT ID : CY/DD/R/07
REV : 00



CYBERNETIK TECHNOLOGIES
PVT.LTD, PUNE

| | |
|----------|--------|
| Date | Name |
| | SHITAL |
| DRAWN | |
| CHECKED | |
| APPROVED | |

| | |
|---------------------|---------|
| PROJECT DESCRIPTION | TITLE |
| HA-382 VOLVO FRANCE | IO LIST |

| | |
|-------------------|--------|
| PROJECT CODE:- | HA-382 |
| DRAWING NUMBER :- | |

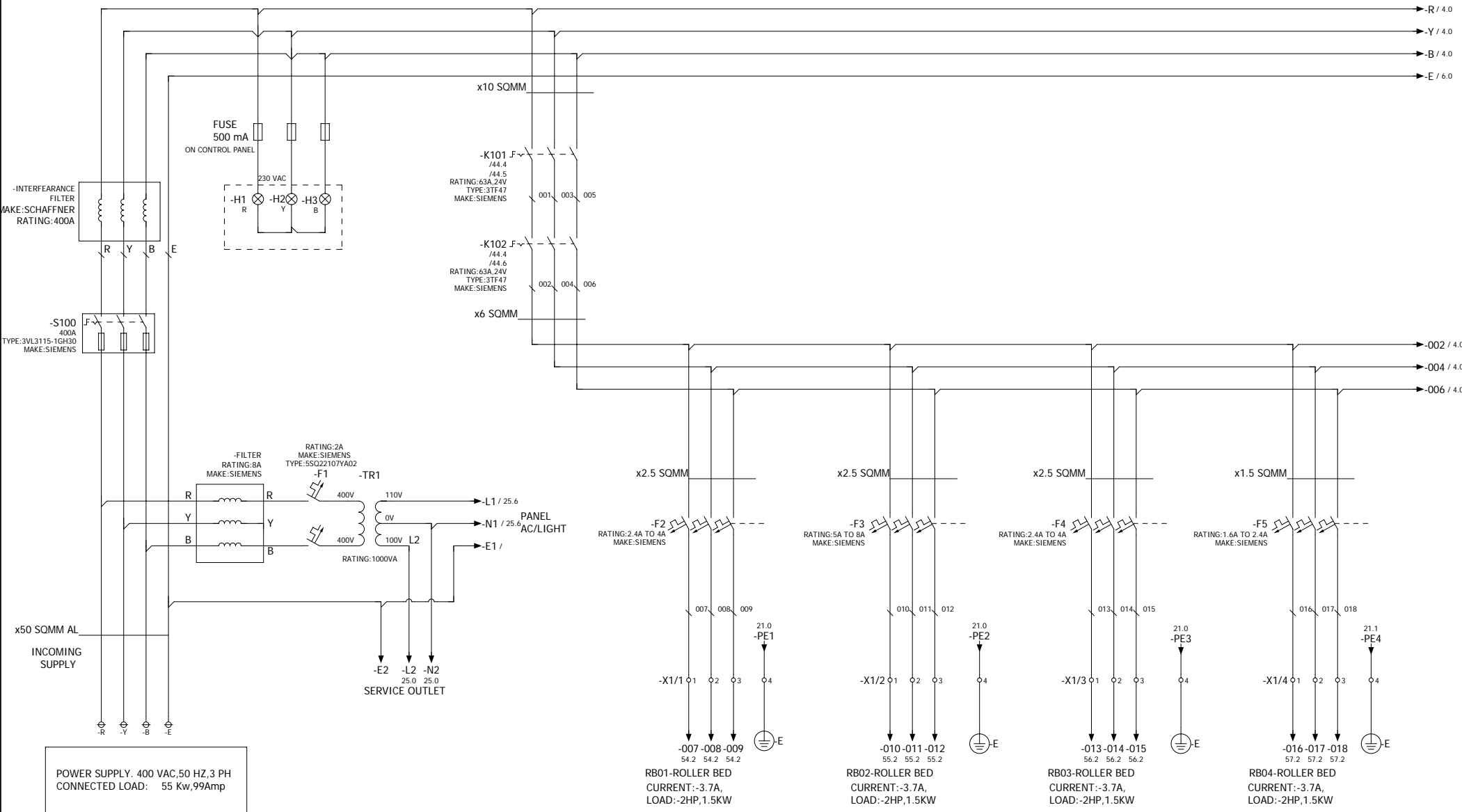

DOCUMENT ID : CY/DD/R/07
 REV : 00

CYBERNETIK TECHNOLOGIES
 PVT.LTD, PUNE

| | |
|----------|--------|
| DATE | NAME |
| | SHITAL |
| CHECKED | |
| APPROVED | |

PROJECT DESCRIPTION
 HA-382 VOLVO FRANCE

TITLE
 POWER DWG-1

| | |
|-------------------|--------|
| PROJECT CODE :- | HA-382 |
| DRAWING NUMBER :- | |
| Page | 3 |
| Pages | 147 |

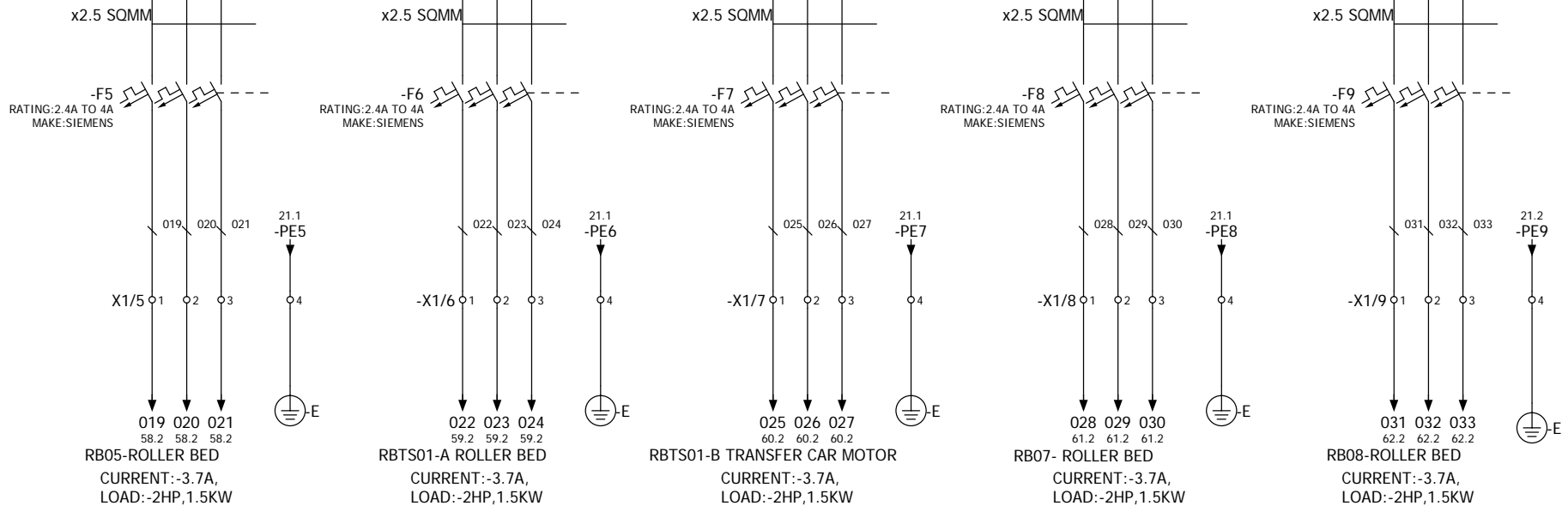
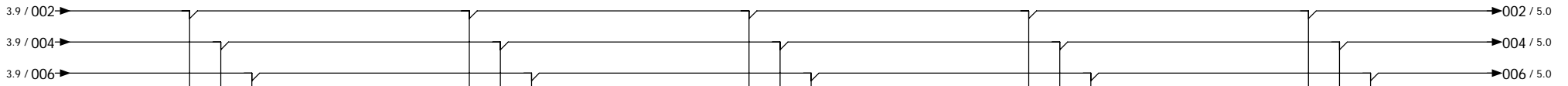
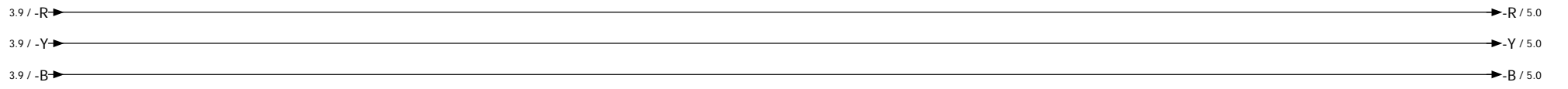

DOCUMENT ID : CY/DD/R/07
REV : 00



CYBERNETIK TECHNOLOGIES
PVT.LTD, PUNE

| | | |
|----------|------|--------|
| DRAWN | Date | Name |
| CHECKED | | SHITAL |
| APPROVED | | |

PROJECT DESCRIPTION
HA-382 VOLVO FRANCE

TITLE
POWER DWG-2

PROJECT CODE :- **HA-382**

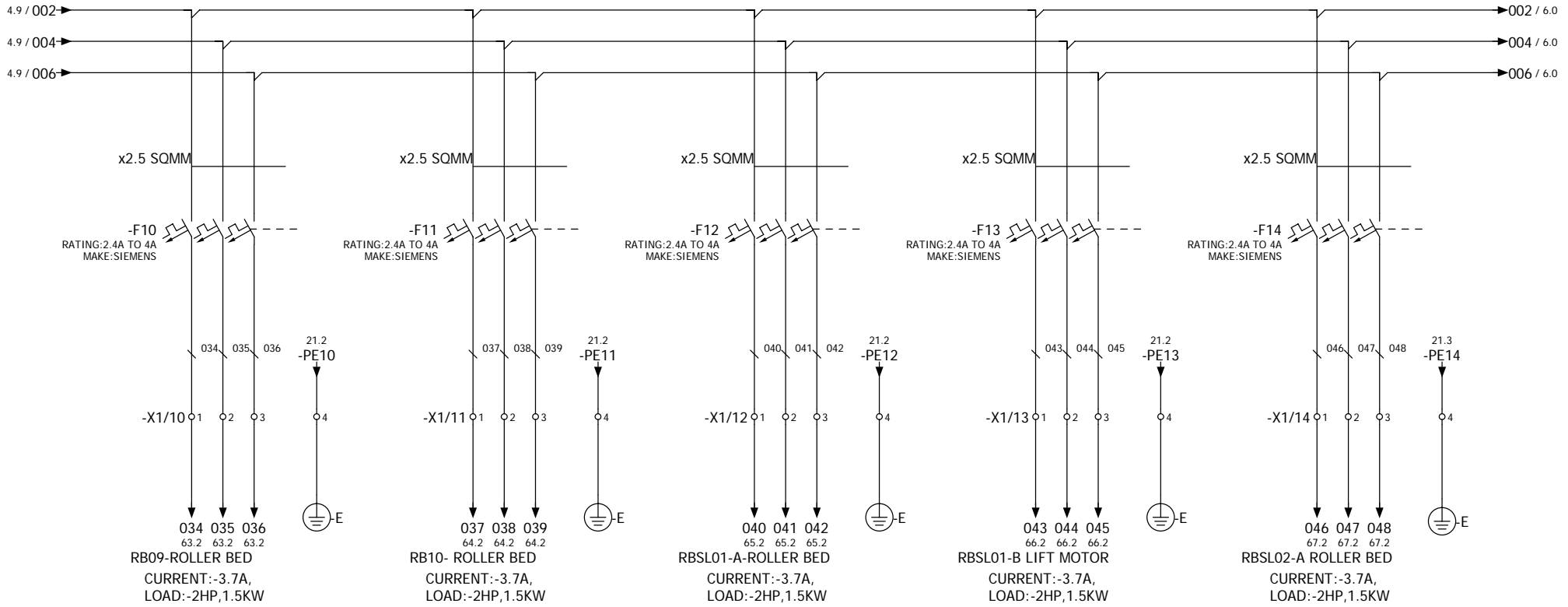
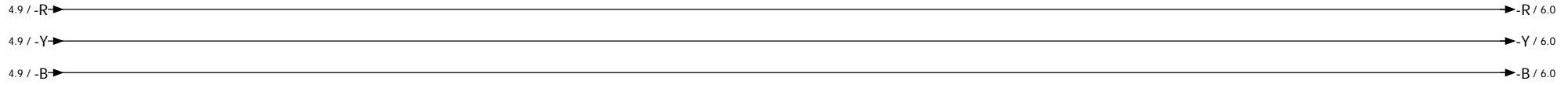

DOCUMENT ID : CY/DD/R/07
 REV : 00

CYBERNETIK TECHNOLOGIES PVT.LTD, PUNE

| | | |
|----------|------|--------|
| Drawn | Date | Name |
| Checked | | SHITAL |
| Approved | | |

PROJECT DESCRIPTION
 HA-382 VOLVO FRANCE

TITLE
 POWER DWG-3

PROJECT CODE :- HA-382

DRAWING NUMBER :-

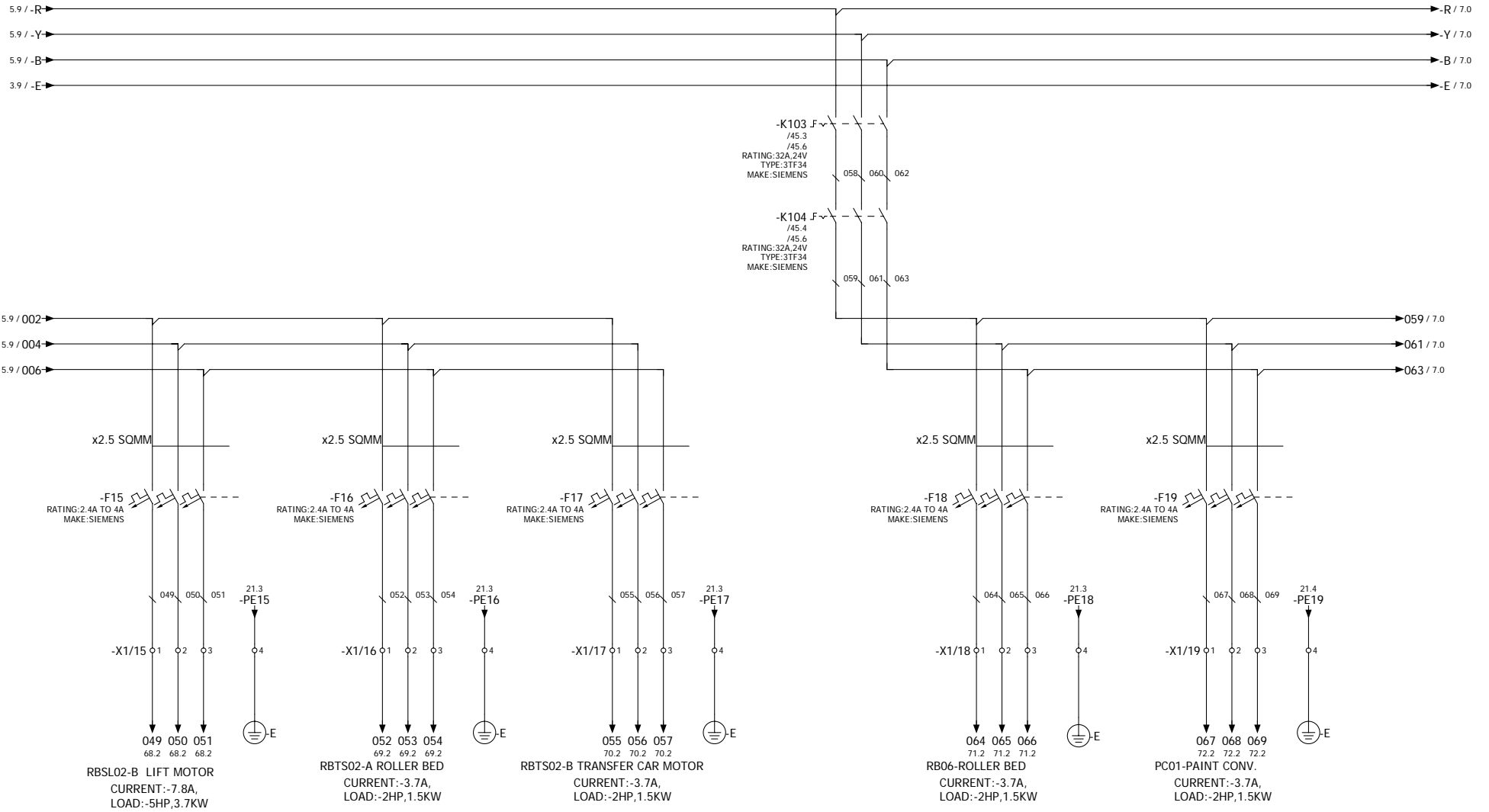

DOCUMENT ID : CY/DD/R/07
 REV : 00

CYBERNETIK TECHNOLOGIES
 PVT.LTD, PUNE

| | |
|----------|--------|
| DATE | NAME |
| CHECKED | SHITAL |
| APPROVED | |

PROJECT DESCRIPTION
 HA-382 VOLVO FRANCE

TITLE
 POWER DWG-4

| | |
|-------------------|--------|
| PROJECT CODE:- | HA-382 |
| DRAWING NUMBER :- | |
| Page | 6 |
| Pages | 147 |

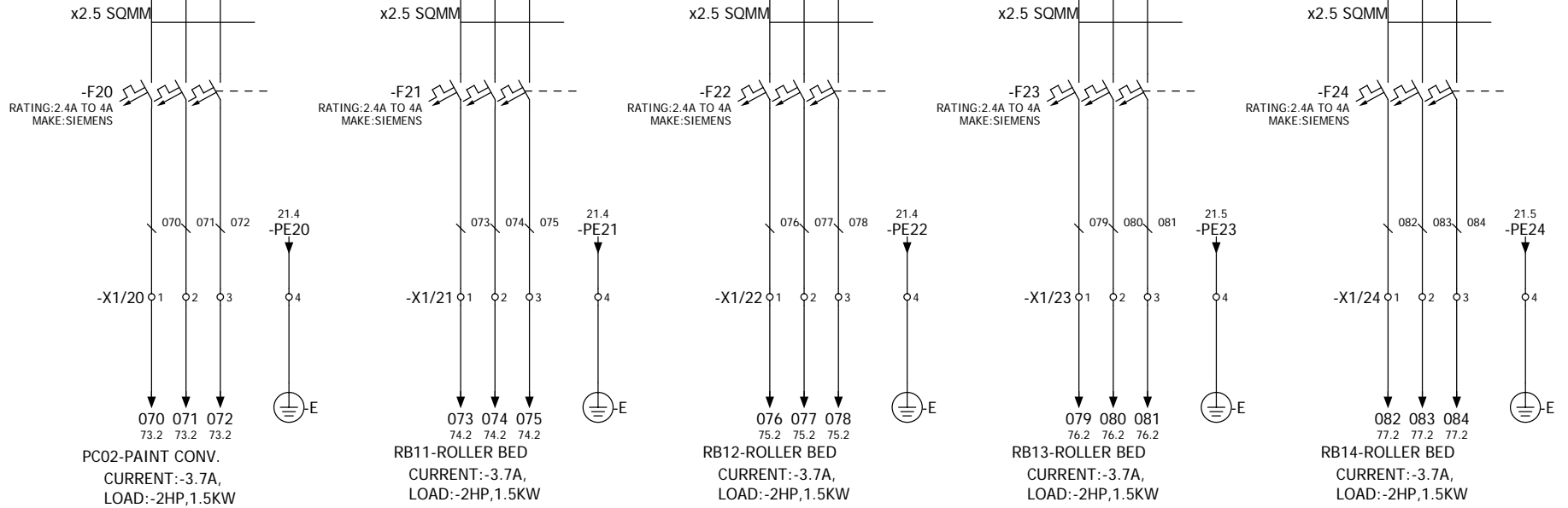
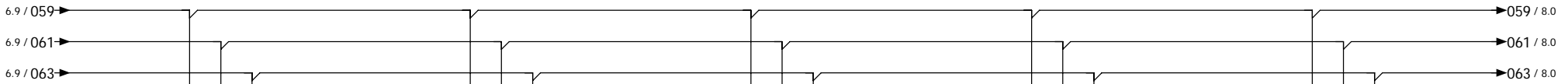
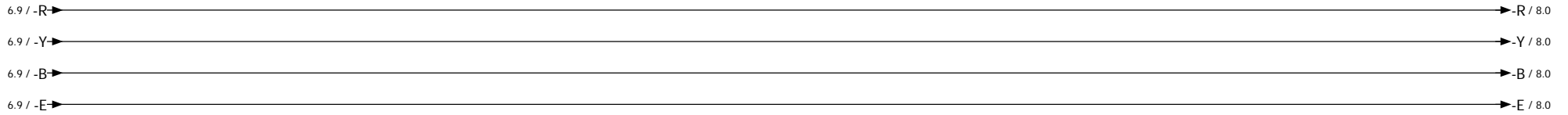

DOCUMENT ID : CY/DD/R/07
 REV : 00

CYBERNETIK TECHNOLOGIES
 PVT.LTD, PUNE

| | | |
|----------|------|--------|
| Drawn | Date | Name |
| CHECKED | | SHITAL |
| APPROVED | | |

PROJECT DESCRIPTION
 HA-382 VOLVO FRANCE

TITLE
 POWER DWG-5

| | |
|-------------------|---------------|
| PROJECT CODE:- | HA-382 |
| DRAWING NUMBER :- | |
| Page | 7 |
| Pages | 147 |

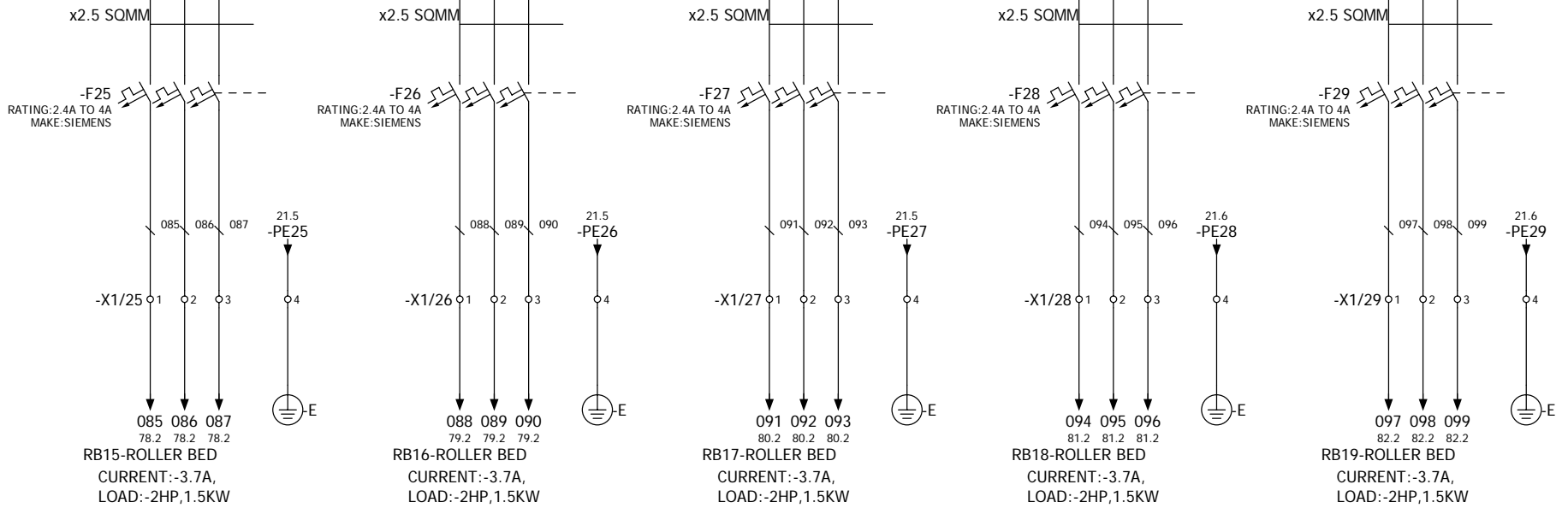
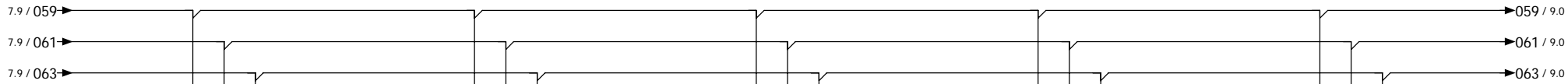
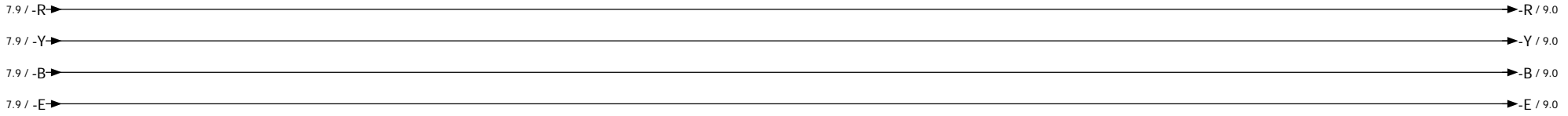

DOCUMENT ID : CY/DD/R/07
 REV : 00

CYBERNETIK TECHNOLOGIES PVT.LTD, PUNE

| | | |
|----------|------|--------|
| Drawn | Date | Name |
| Checked | | SHITAL |
| Approved | | |

PROJECT DESCRIPTION
 HA-382 VOLVO FRANCE

TITLE
 POWER DWG-6

PROJECT CODE :- HA-382
 DRAWING NUMBER :-
 Page 8
 Pages 147

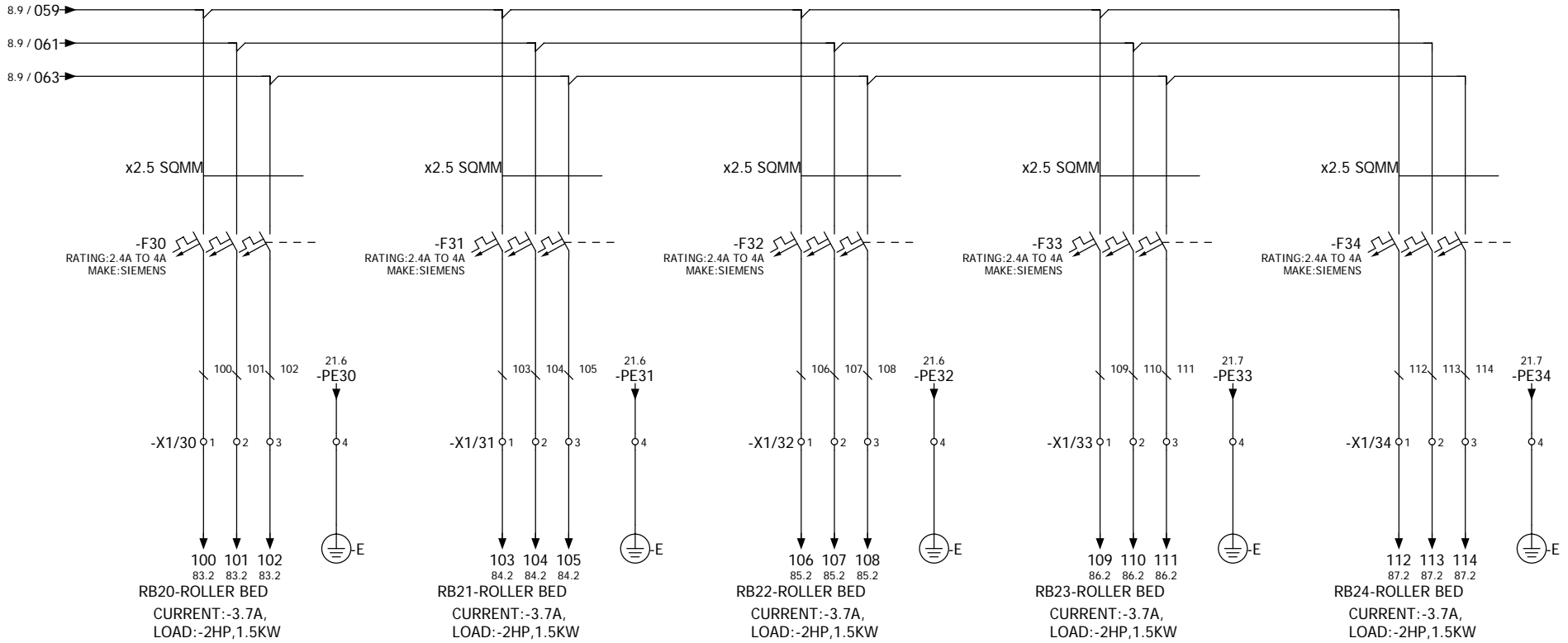
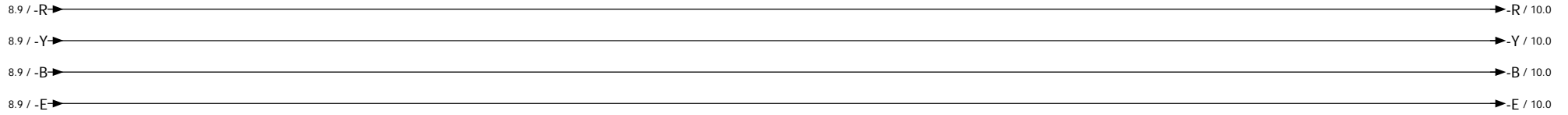

DOCUMENT ID : CY/DD/R/07
REV : 00



CYBERNETIK TECHNOLOGIES
PVT.LTD, PUNE

| | | |
|----------|------|--------|
| Drawn | Date | Name |
| Checked | | SHITAL |
| Approved | | |

| | |
|---------------------|-------------|
| PROJECT DESCRIPTION | TITLE |
| HA-382 VOLVO FRANCE | POWER DWG-7 |

| | |
|-------------------|--------|
| PROJECT CODE :- | HA-382 |
| DRAWING NUMBER :- | |

| | |
|-------|-----|
| Page | 9 |
| Pages | 147 |

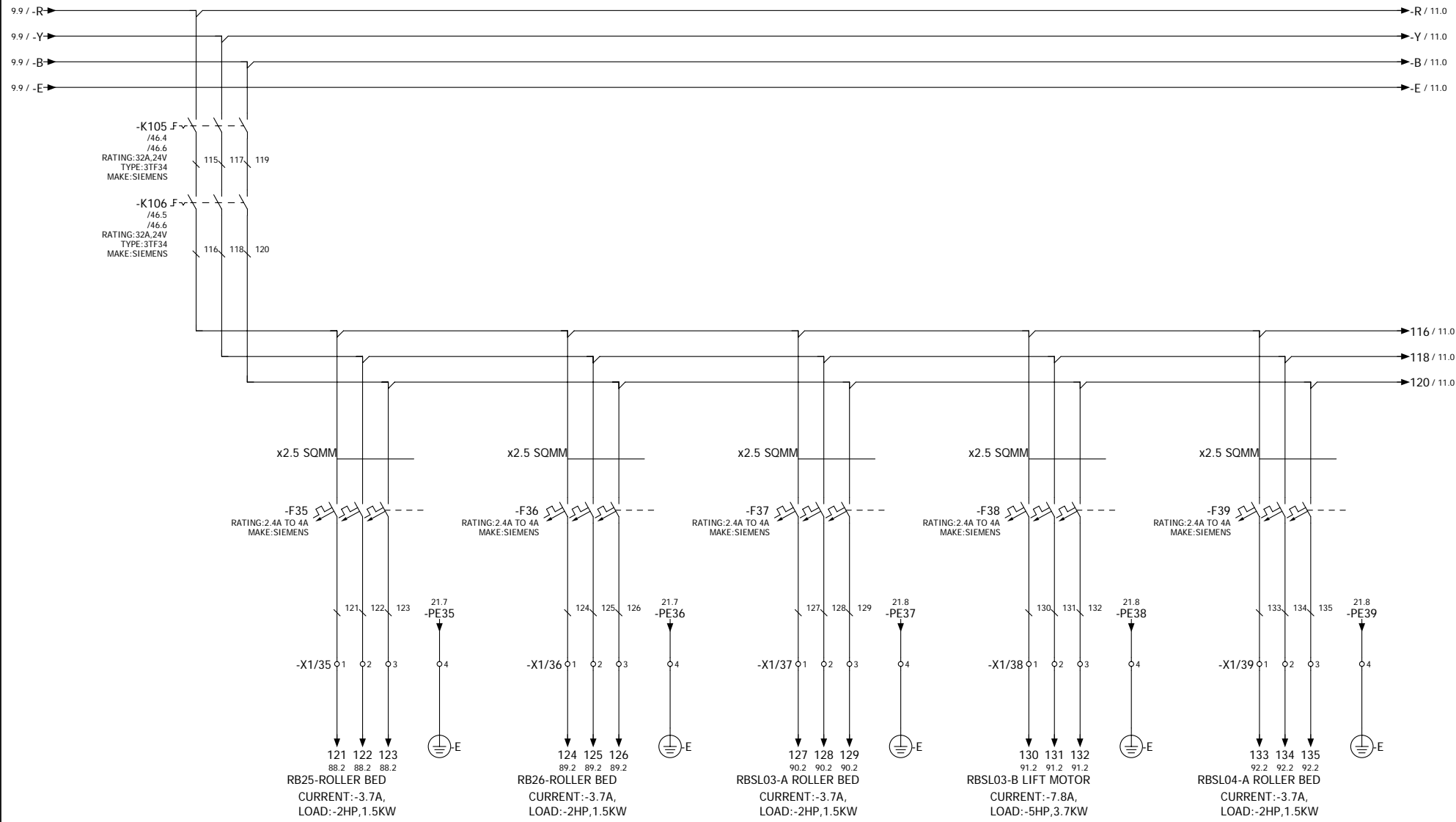

DOCUMENT ID : CY/DD/R/07
REV : 00

CYBERNETIK TECHNOLOGIES
PVT.LTD, PUNE

| | Date | Name |
|----------|------|--------|
| DRAWN | | SHITAL |
| CHECKED | | |
| APPROVED | | |

PROJECT DESCRIPTION
HA-382 VOLVO FRANCE

TITLE
POWER DWG-8

| | |
|-------------------|---------------|
| PROJECT CODE :- | HA-382 |
| DRAWING NUMBER :- | |
| Page | 10 |
| Pages | 147 |

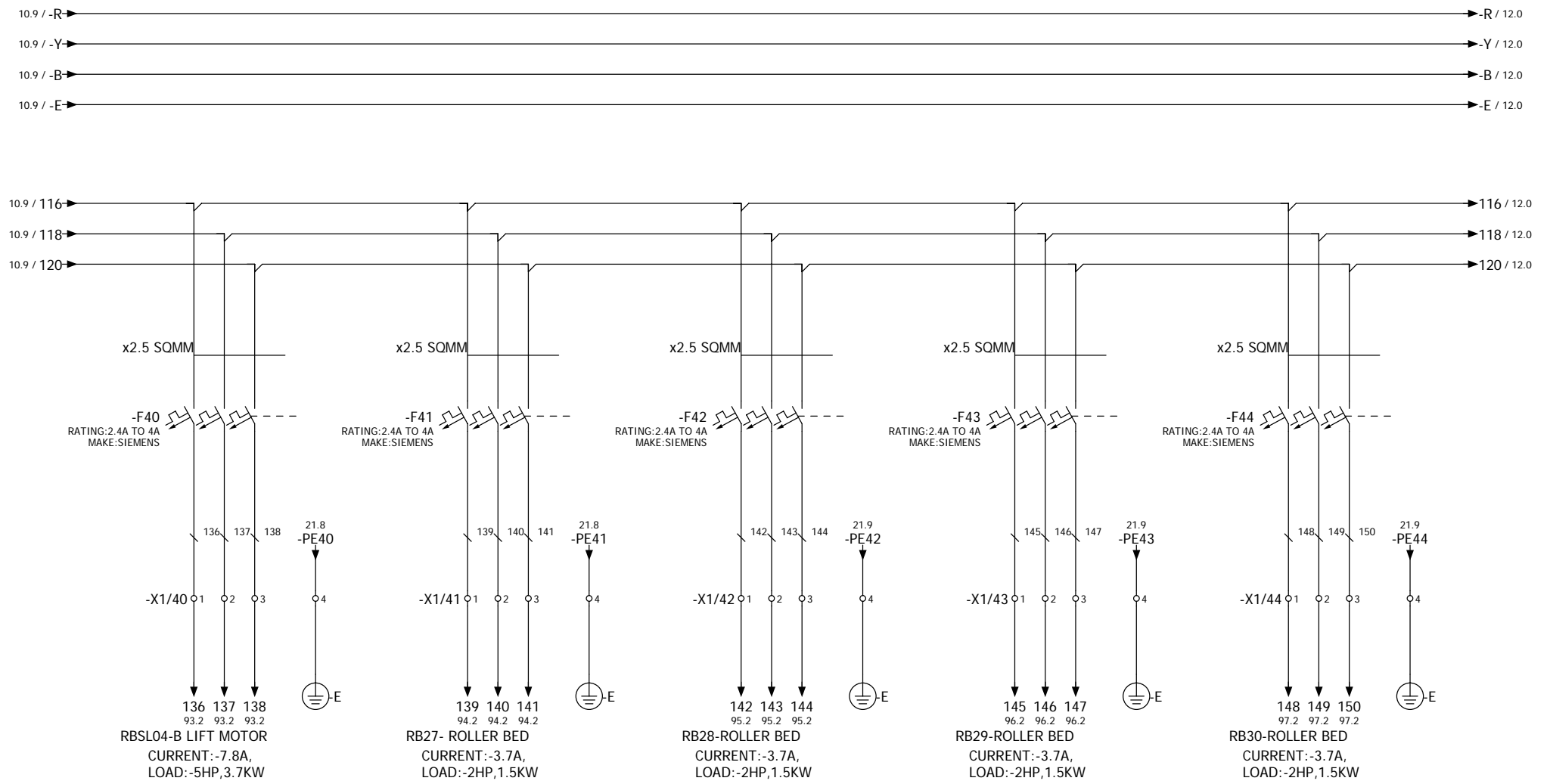

DOCUMENT ID : CY/DD/R/07
REV : 00



CYBERNETIK TECHNOLOGIES
PVT.LTD, PUNE

| | | |
|----------|------|--------|
| Drawn | Date | Name |
| Checked | | SHITAL |
| Approved | | |

PROJECT DESCRIPTION
HA-382 VOLVO FRANCE

TITLE
POWER DWG-9

PROJECT CODE :- **HA-382**
DRAWING NUMBER :-

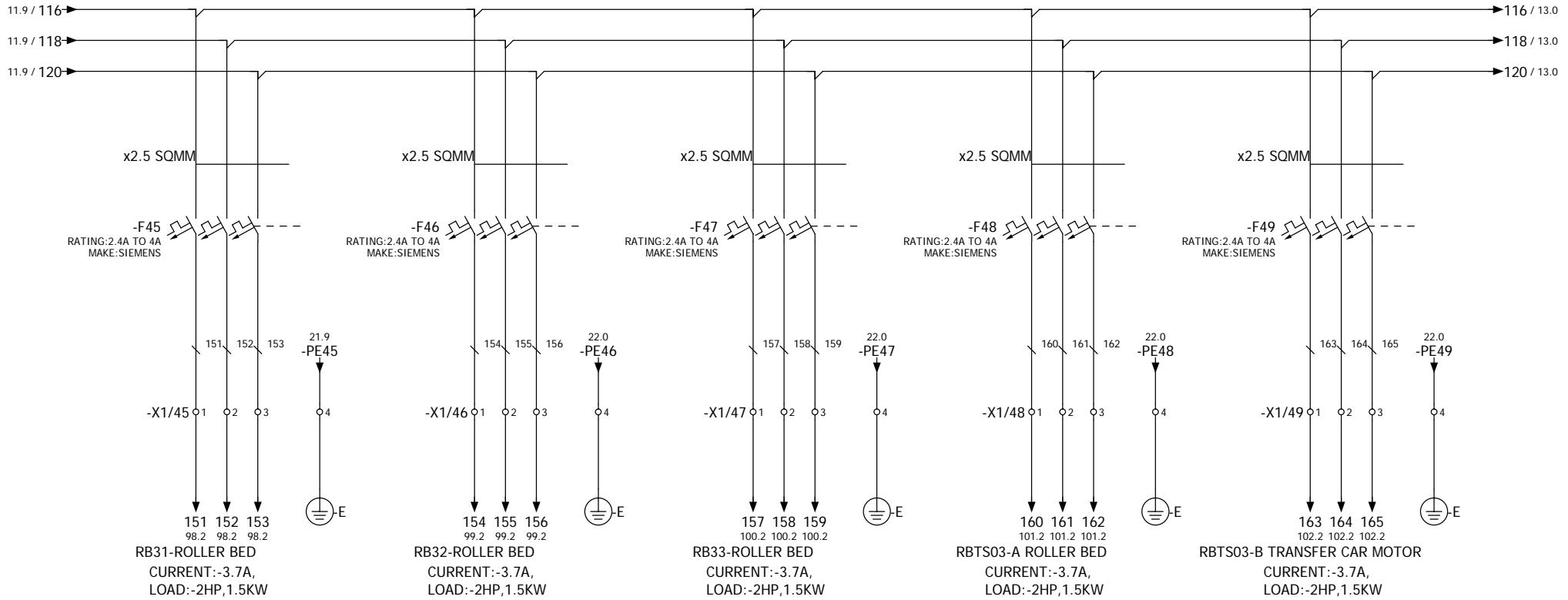
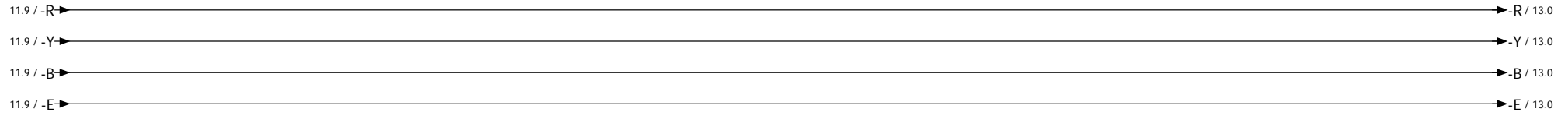

DOCUMENT ID : CY/DD/R/07
 REV : 00



CYBERNETIK TECHNOLOGIES
 PVT.LTD, PUNE

| | | |
|----------|------|--------|
| Drawn | Date | Name |
| Checked | | SHITAL |
| Approved | | |

| | |
|---------------------|--------------|
| PROJECT DESCRIPTION | TITLE |
| HA-382 VOLVO FRANCE | POWER DWG-10 |

| | |
|-------------------|--------|
| PROJECT CODE :- | HA-382 |
| DRAWING NUMBER :- | |

| | |
|-------|-----|
| Page | 12 |
| Pages | 147 |

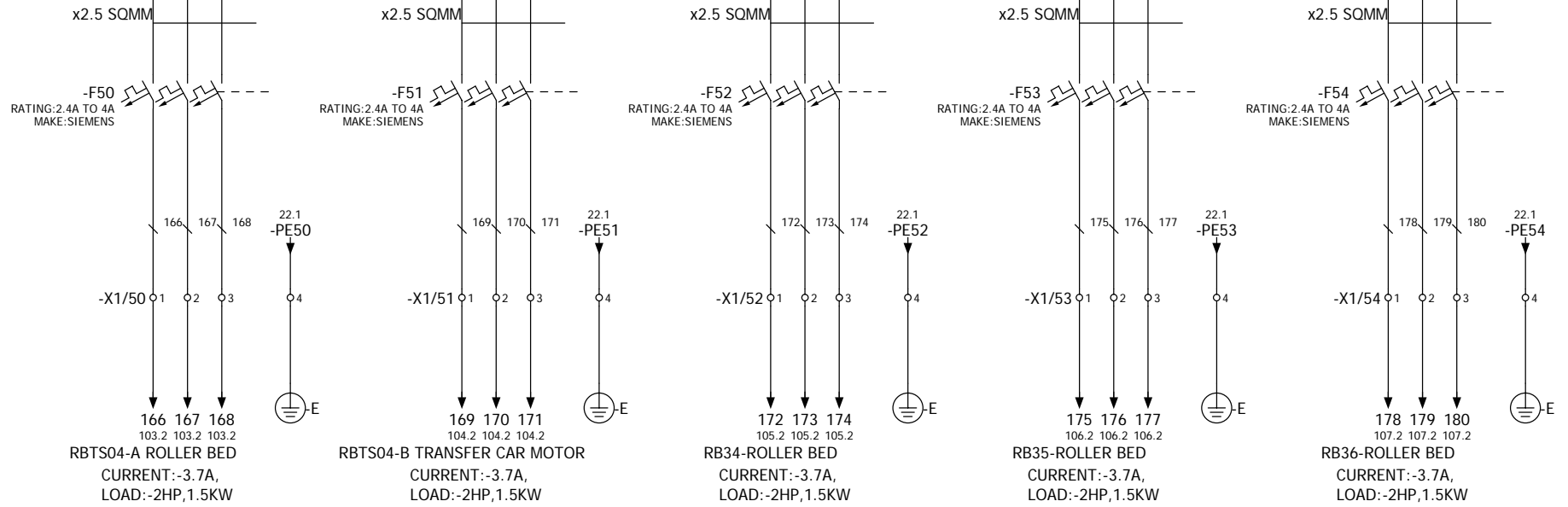
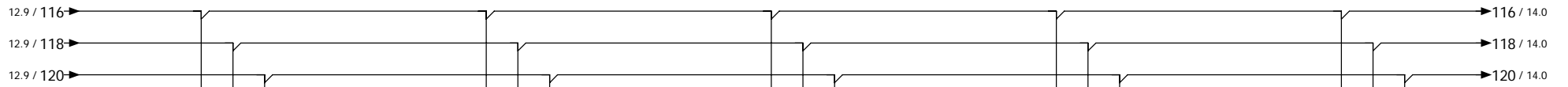
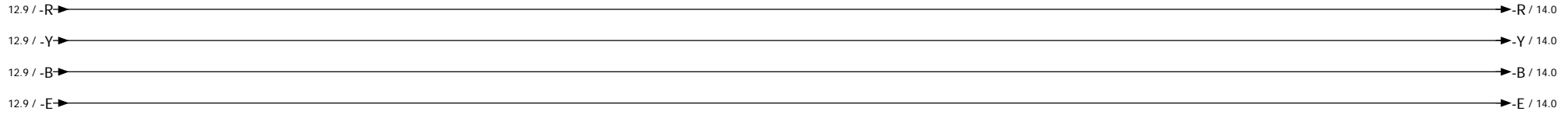

DOCUMENT ID : CY/DD/R/07
 REV : 00

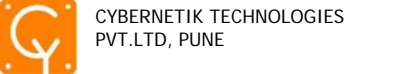

| | | | | | | |
|------------------------------|------|--------|---------------------|--------------|-------------------|----------------------|
| DRAWN CHECKED APPROVED | Date | Name | PROJECT DESCRIPTION | TITLE | PROJECT CODE :- | HA-382 |
| | | SHITAL | HA-382 VOLVO FRANCE | POWER DWG-11 | DRAWING NUMBER :- | |
| | | | | | | Page 13 Pages 147 |

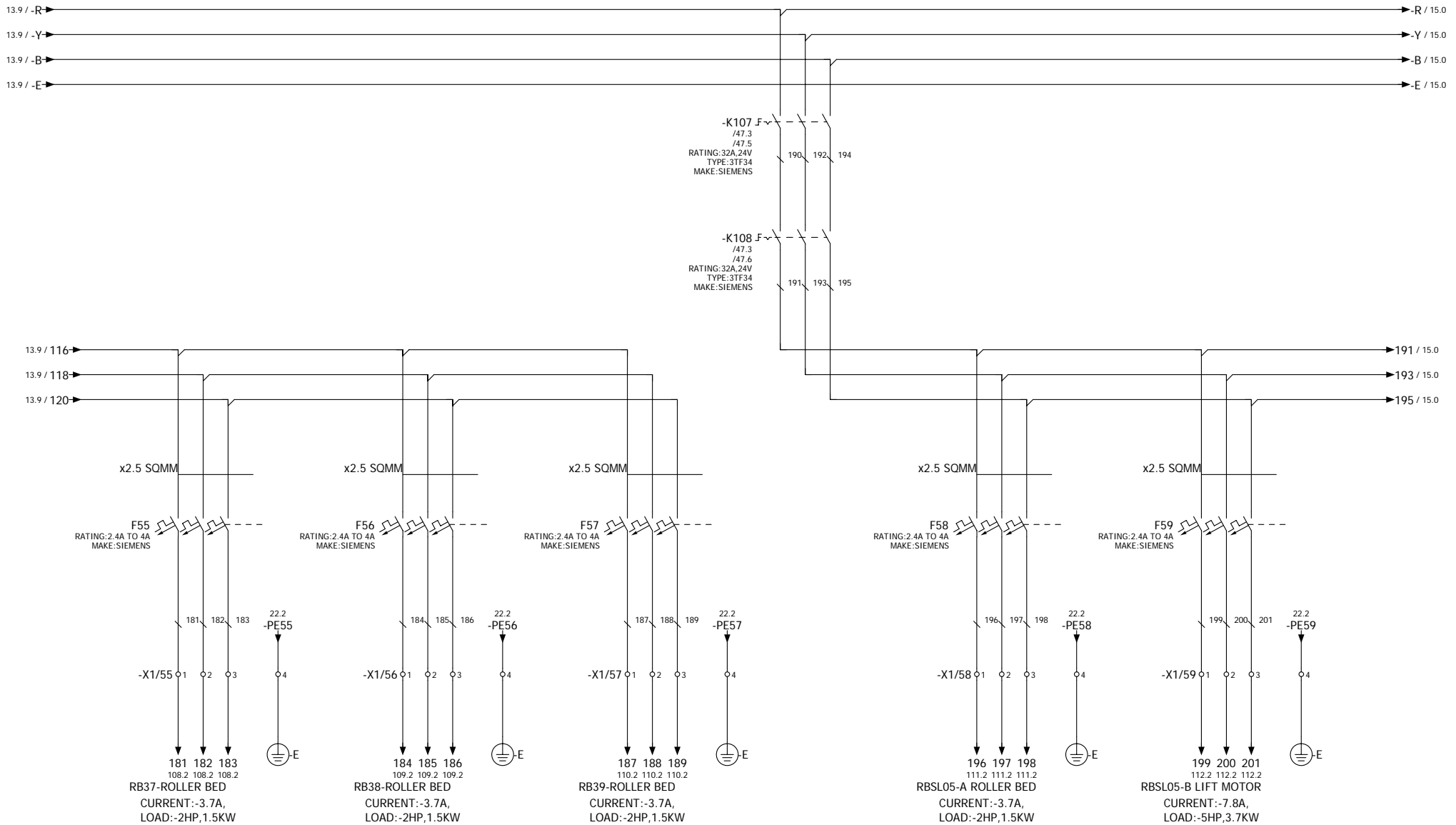

DOCUMENT ID : CY/DD/R/07
REV : 00



CYBERNETIK TECHNOLOGIES
PVT.LTD, PUNE

| | | |
|----------|------|--------|
| Drawn | Date | Name |
| CHECKED | | SHITAL |
| APPROVED | | |

PROJECT DESCRIPTION
HA-382 VOLVO FRANCE

TITLE
POWER DWG-12

| | |
|-------------------|---------------|
| PROJECT CODE :- | HA-382 |
| DRAWING NUMBER :- | |
| Page | 14 |
| Pages | 147 |

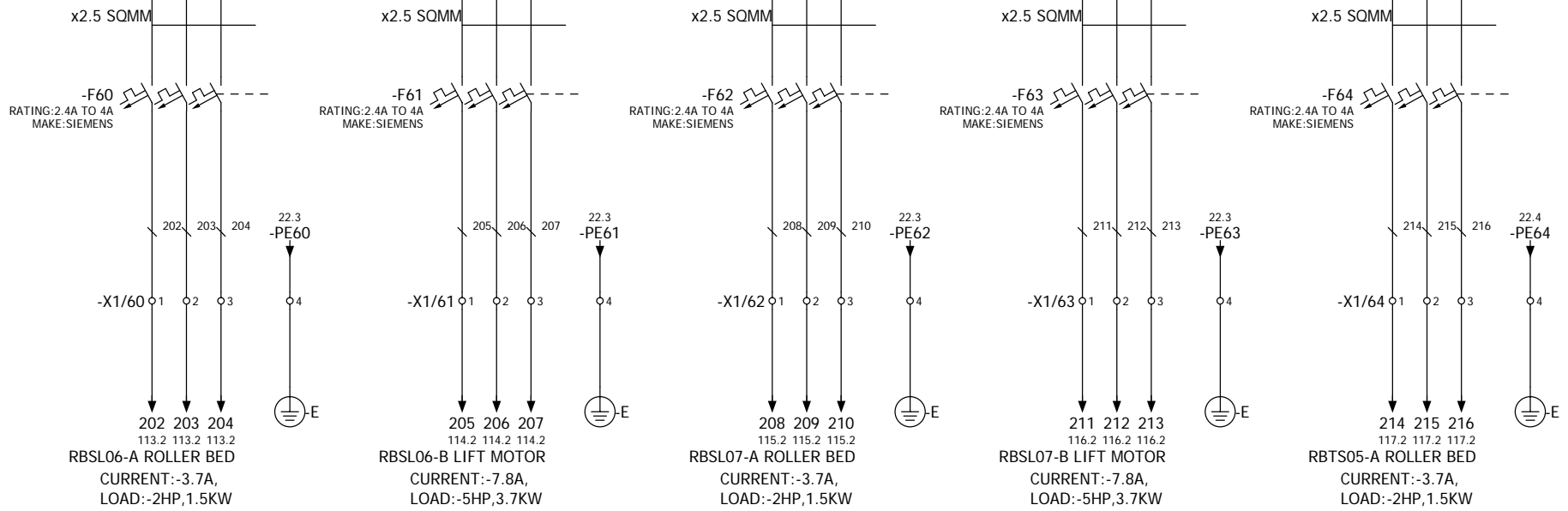
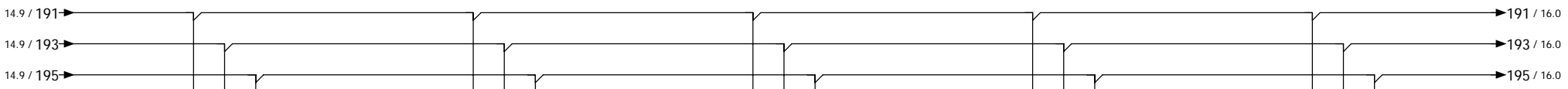
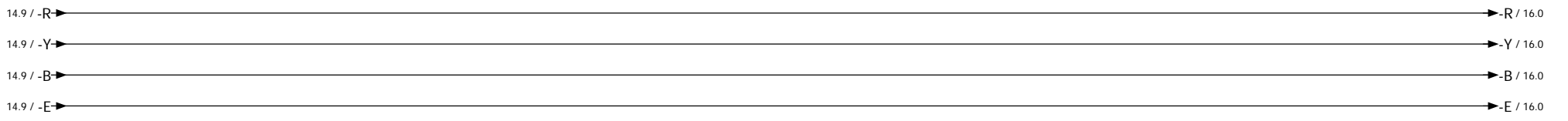

DOCUMENT ID : CY/DD/R/07
REV : 00



CYBERNETIK TECHNOLOGIES
PVT.LTD, PUNE

| | | |
|----------|------|--------|
| DRAWN | Date | Name |
| CHECKED | | SHITAL |
| APPROVED | | |

PROJECT DESCRIPTION
HA-382 VOLVO FRANCE

TITLE
POWER DWG-13

PROJECT CODE :- **HA-382**
DRAWING NUMBER :-

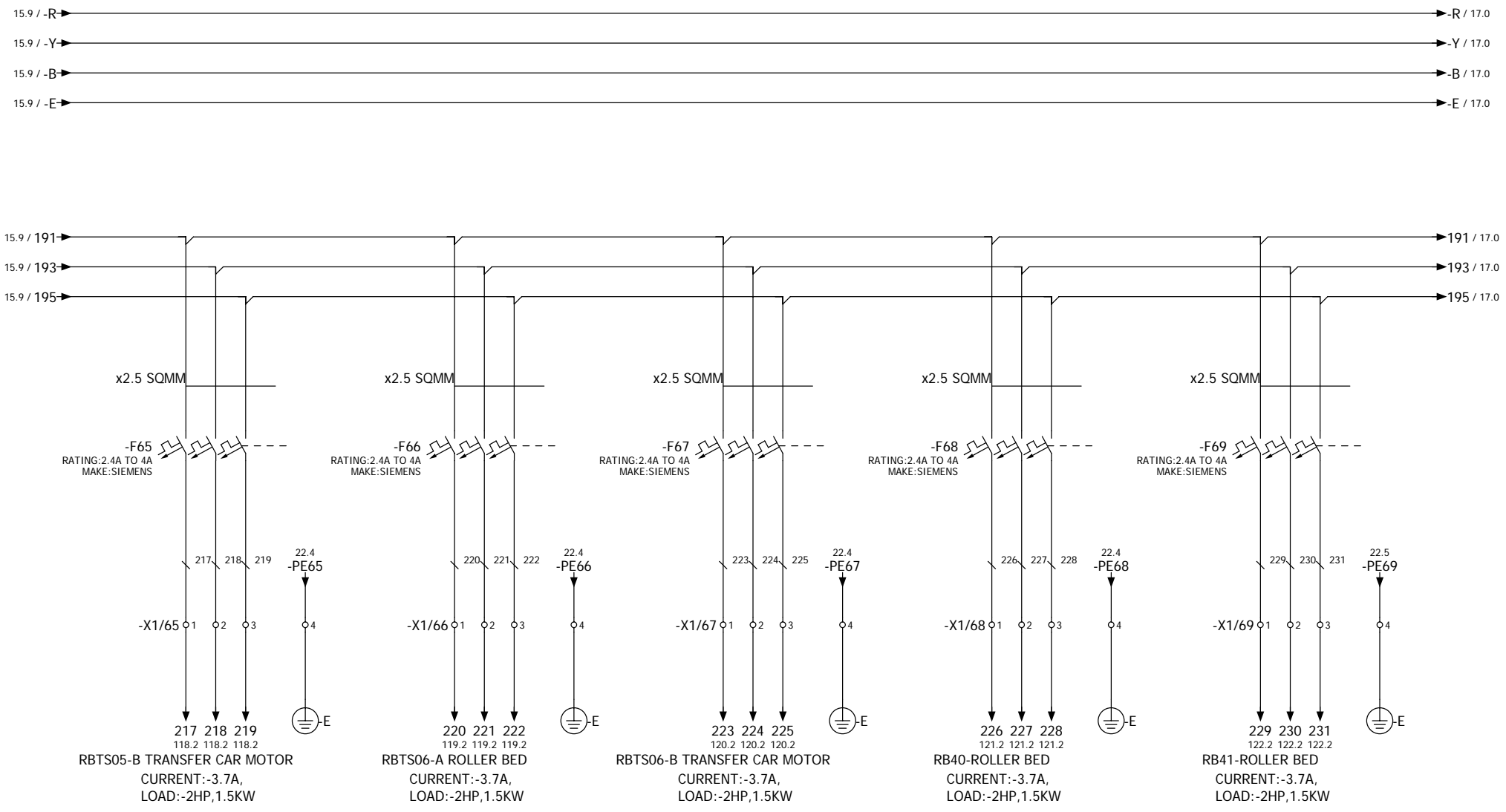

DOCUMENT ID : CY/DD/R/07
REV : 00

CYBERNETIK TECHNOLOGIES
PVT.LTD, PUNE

| | | |
|----------|------|--------|
| DRAWN | Date | Name |
| CHECKED | | SHITAL |
| APPROVED | | |

PROJECT DESCRIPTION
HA-382 VOLVO FRANCE

TITLE
POWER DWG-14

| | |
|-------------------|---------------|
| PROJECT CODE :- | HA-382 |
| DRAWING NUMBER :- | |
| Page | 16 |
| Pages | 147 |

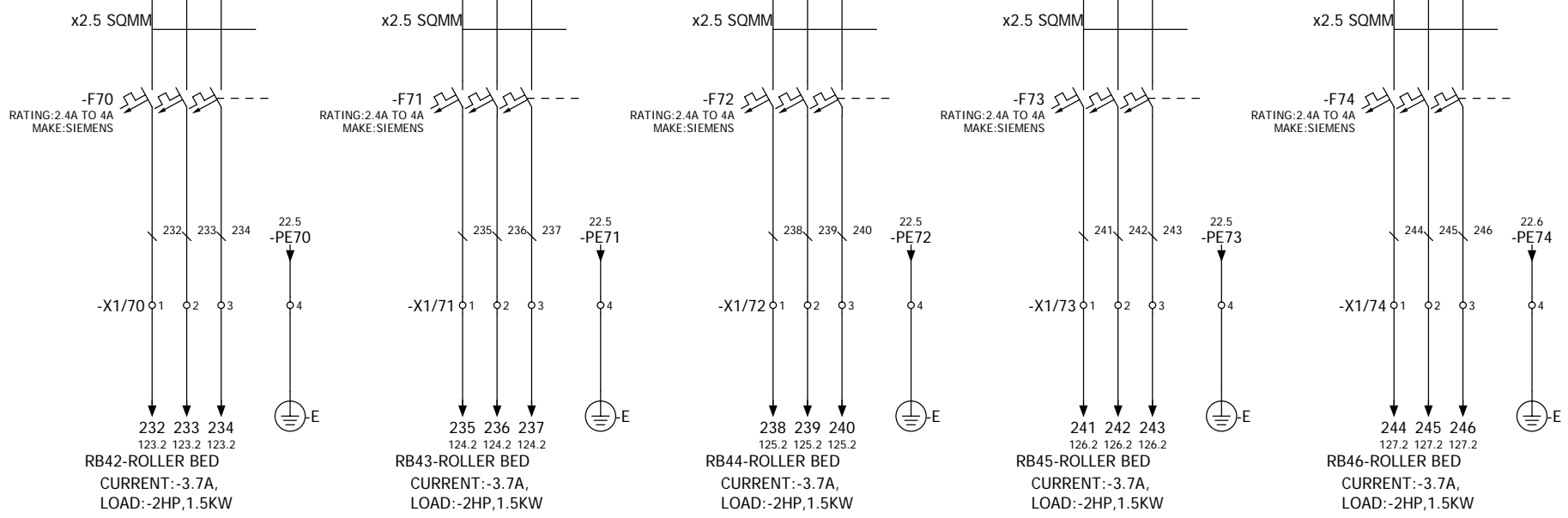
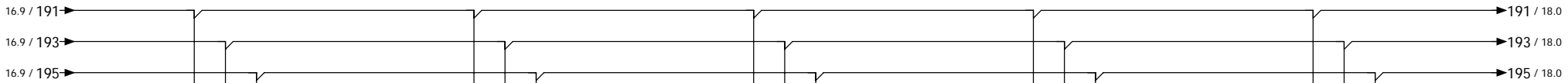
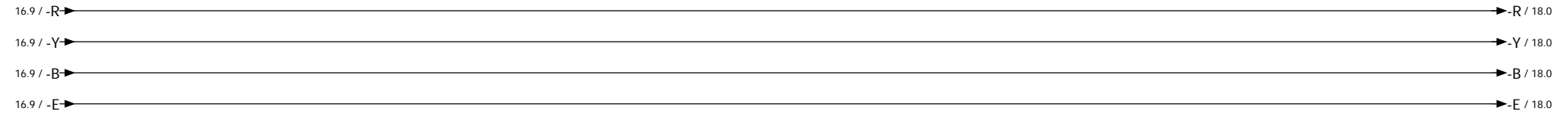

DOCUMENT ID : CY/DD/R/07
REV : 00



CYBERNETIK TECHNOLOGIES
PVT.LTD, PUNE

| | |
|----------|--------|
| DATE | NAME |
| CHECKED | SHITAL |
| APPROVED | |

PROJECT DESCRIPTION
HA-382 VOLVO FRANCE

TITLE
POWER DWG-15

PROJECT CODE :- **HA-382**
DRAWING NUMBER :-

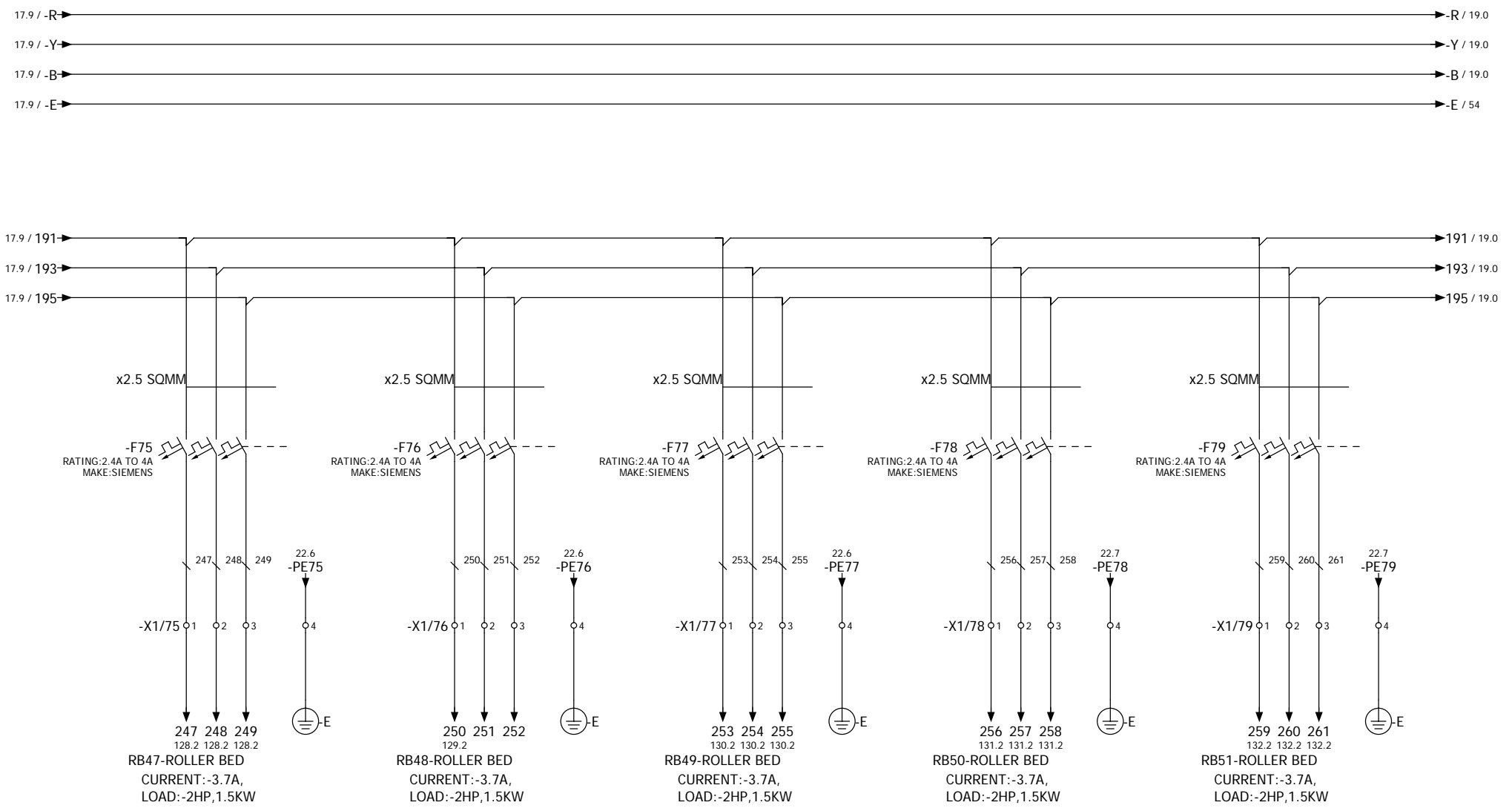

DOCUMENT ID : CY/DD/R/07
 REV : 00

CYBERNETIK TECHNOLOGIES PVT.LTD, PUNE

| | | |
|----------|------|--------|
| DRAWN | Date | Name |
| CHECKED | | SHITAL |
| APPROVED | | |

PROJECT DESCRIPTION
 HA-382 VOLVO FRANCE

TITLE
 POWER DWG-16

| | |
|--------------------------|---------------|
| PROJECT CODE:- | HA-382 |
| DRAWING NUMBER :- | |
| | Page 18 |
| | Pages 147 |

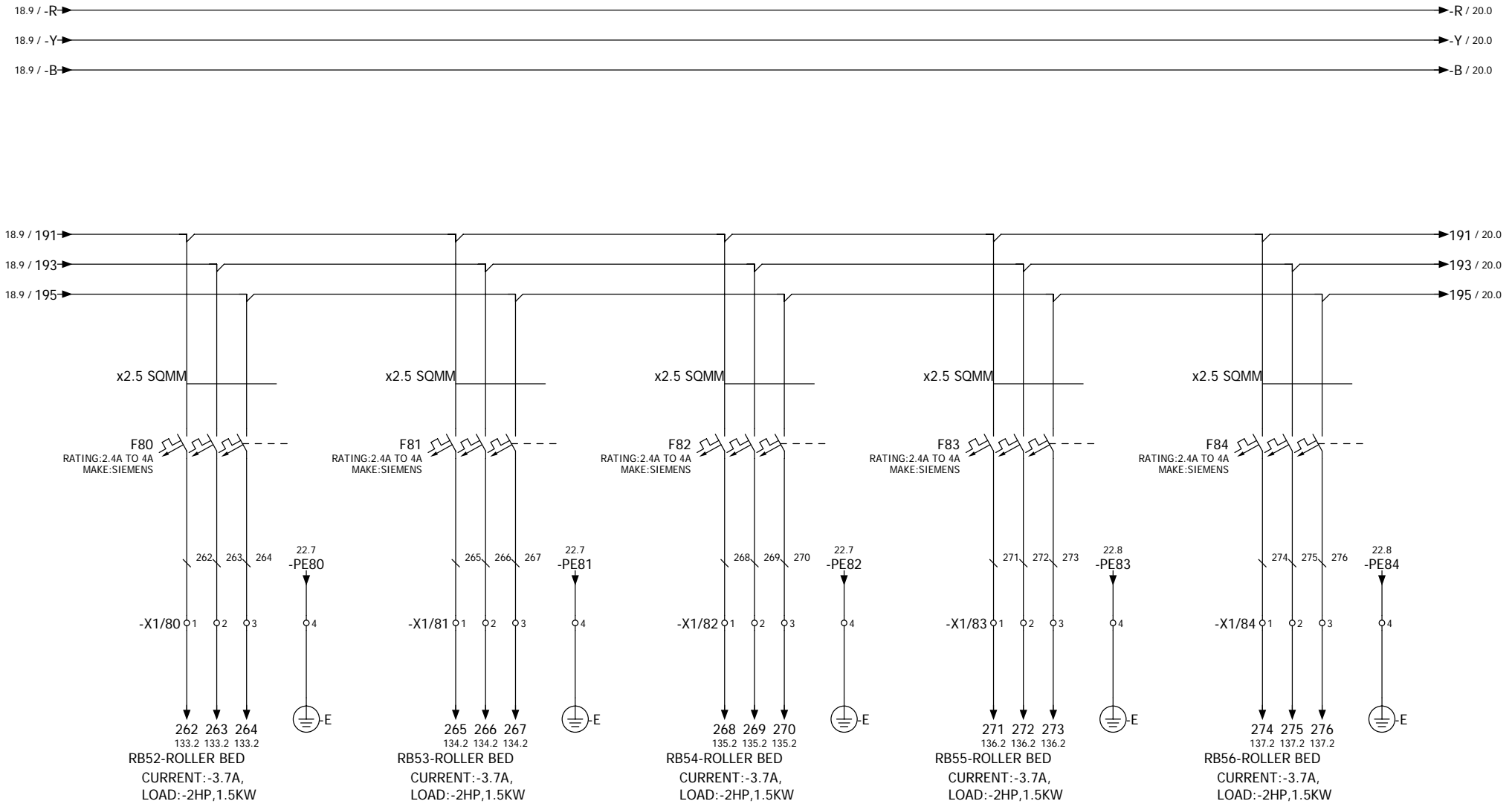

DOCUMENT ID : CY/DD/R/07
REV : 00

CYBERNETIK TECHNOLOGIES
PVT.LTD, PUNE

| | | |
|----------|------|--------|
| DRAWN | Date | Name |
| CHECKED | | SHITAL |
| APPROVED | | |

PROJECT DESCRIPTION
HA-382 VOLVO FRANCE

TITLE
POWER DWG-17

| | |
|-------------------|--------|
| PROJECT CODE :- | HA-382 |
| DRAWING NUMBER :- | |
| Page | 19 |
| Pages | 147 |

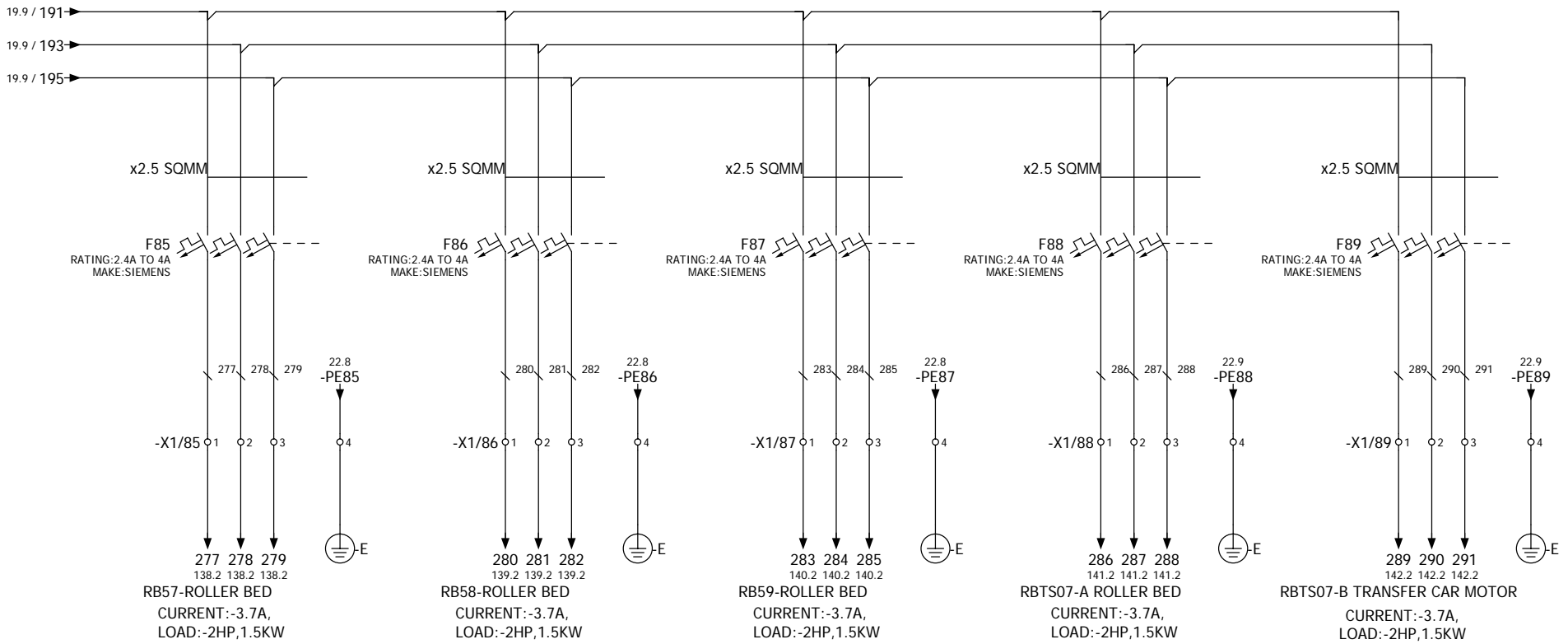
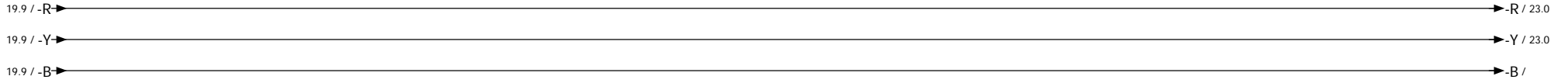

DOCUMENT ID : CY/DD/R/07
 REV : 00



CYBERNETIK TECHNOLOGIES
 PVT.LTD, PUNE

| | | |
|----------|------|--------|
| Drawn | Date | Name |
| Checked | | SHITAL |
| Approved | | |

PROJECT DESCRIPTION
 HA-382 VOLVO FRANCE

TITLE
 POWER DWG-18

| | |
|-------------------|--------|
| PROJECT CODE :- | HA-382 |
| DRAWING NUMBER :- | |
| Page | 20 |
| Pages | 147 |

0

1

2

3

4

5

6

7

8

9

EARTHING BUS BAR

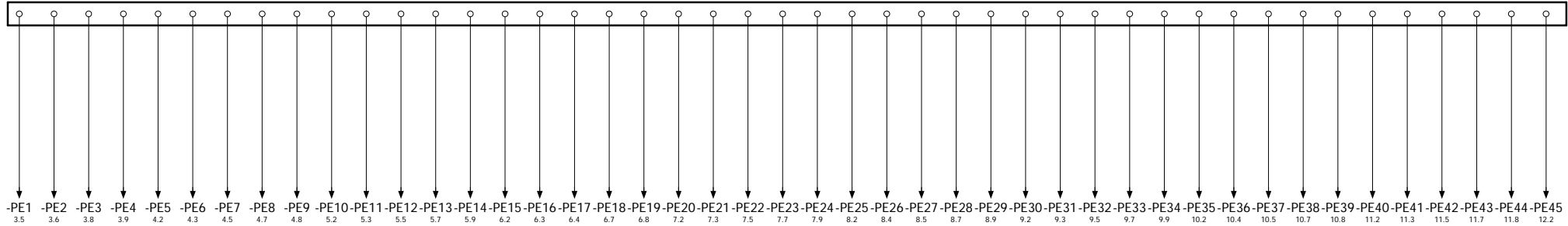

DOCUMENT ID : CY/DD/R/07
REV : 00



CYBERNETIK TECHNOLOGIES
PVT.LTD, PUNE

| | | |
|----------|------|--------|
| | Date | Name |
| DRAWN | | SHITAL |
| CHECKED | | |
| APPROVED | | |

| | |
|---------------------|----------|
| PROJECT DESCRIPTION | TITLE |
| HA-382 VOLVO FRANCE | EARTHING |

| | |
|-------------------|--------|
| PROJECT CODE:- | HA-382 |
| DRAWING NUMBER :- | |

| | |
|-------|-----|
| Page | 21 |
| Pages | 147 |

0

1

2

3

4

5

6

7

8

9

EARTHING BUS BAR

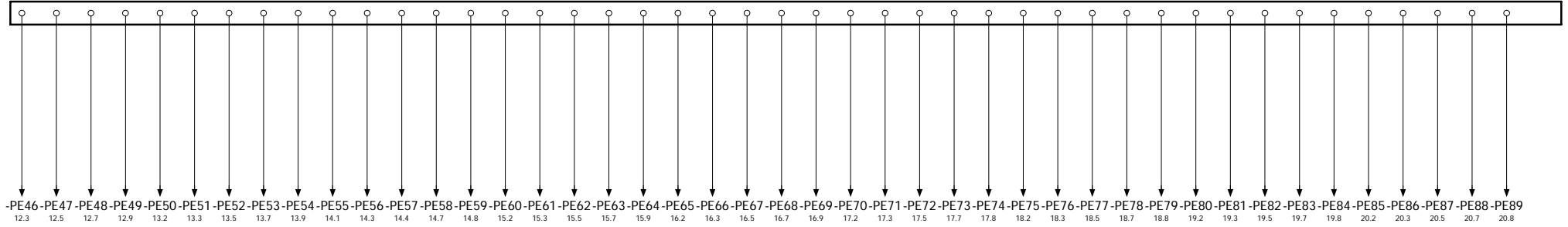

DOCUMENT ID : CY/DD/R/07
REV : 00

 CYBERNETIK TECHNOLOGIES
PVT.LTD, PUNE

| | | |
|----------|------|--------|
| Drawn | Date | Name |
| CHECKED | | SHITAL |
| APPROVED | | |

PROJECT DESCRIPTION
HA-382 VOLVO FRANCE

TITLE
EARTHING-2

| | |
|-------------------|---------------|
| PROJECT CODE:- | HA-382 |
| DRAWING NUMBER :- | |
| Page | 22 |
| Pages | 147 |

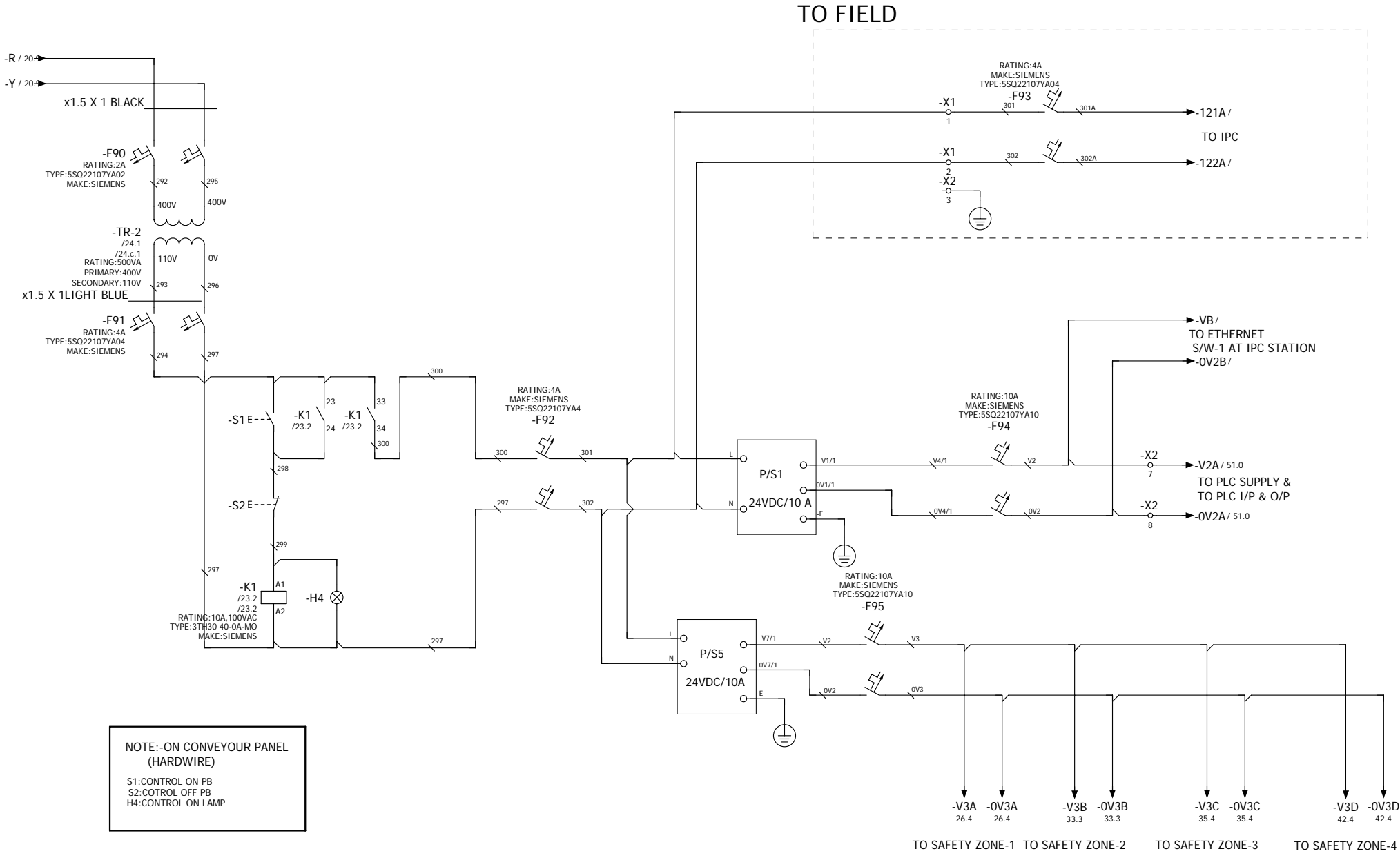

DOCUMENT ID : CY/DD/R/07
REV : 00

CYBERNETIK TECHNOLOGIES
PVT.LTD, PUNE

| | | |
|----------|------|--------|
| DRAWN | Date | Name |
| CHECKED | | SHITAL |
| APPROVED | | |

PROJECT DESCRIPTION
HA-382 VOLVO FRANCE

TITLE
CONTROL CKT-1

PROJECT CODE:- **HA-382**
DRAWING NUMBER :-
Page 23
Pages 147

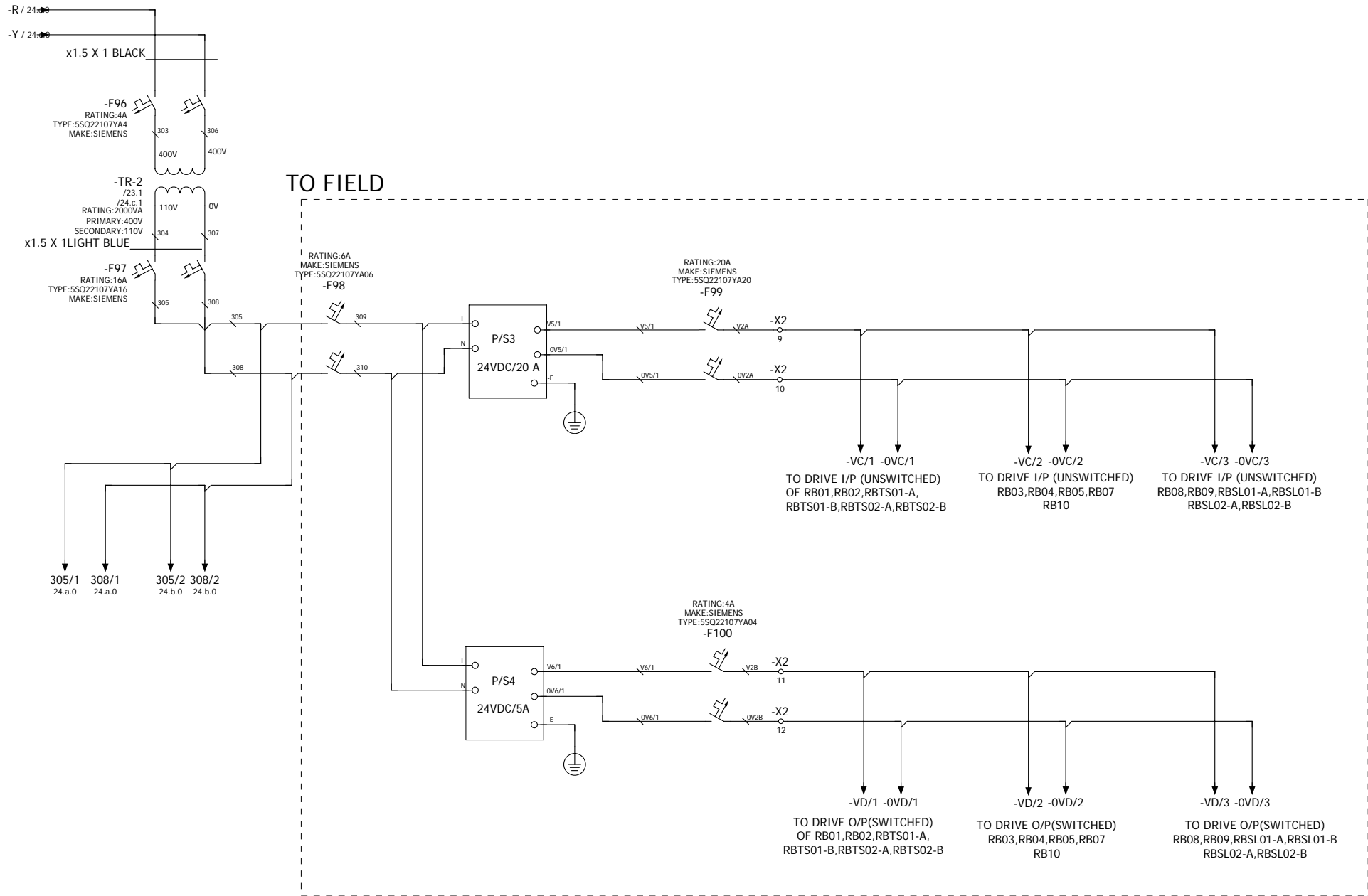

DOCUMENT ID : CY/DD/R/07
 REV : 00

| | | |
|----------|------|--------|
| Drawn | Date | Name |
| Checked | | SHITAL |
| Approved | | |

PROJECT DESCRIPTION
 HA-382 VOLVO FRANCE

TITLE
 CONTROL CKT-2

| | |
|--------------------------|---------------|
| PROJECT CODE :- | HA-382 |
| DRAWING NUMBER :- | |
| Page | 24 |
| Pages | 147 |

TO FIELD

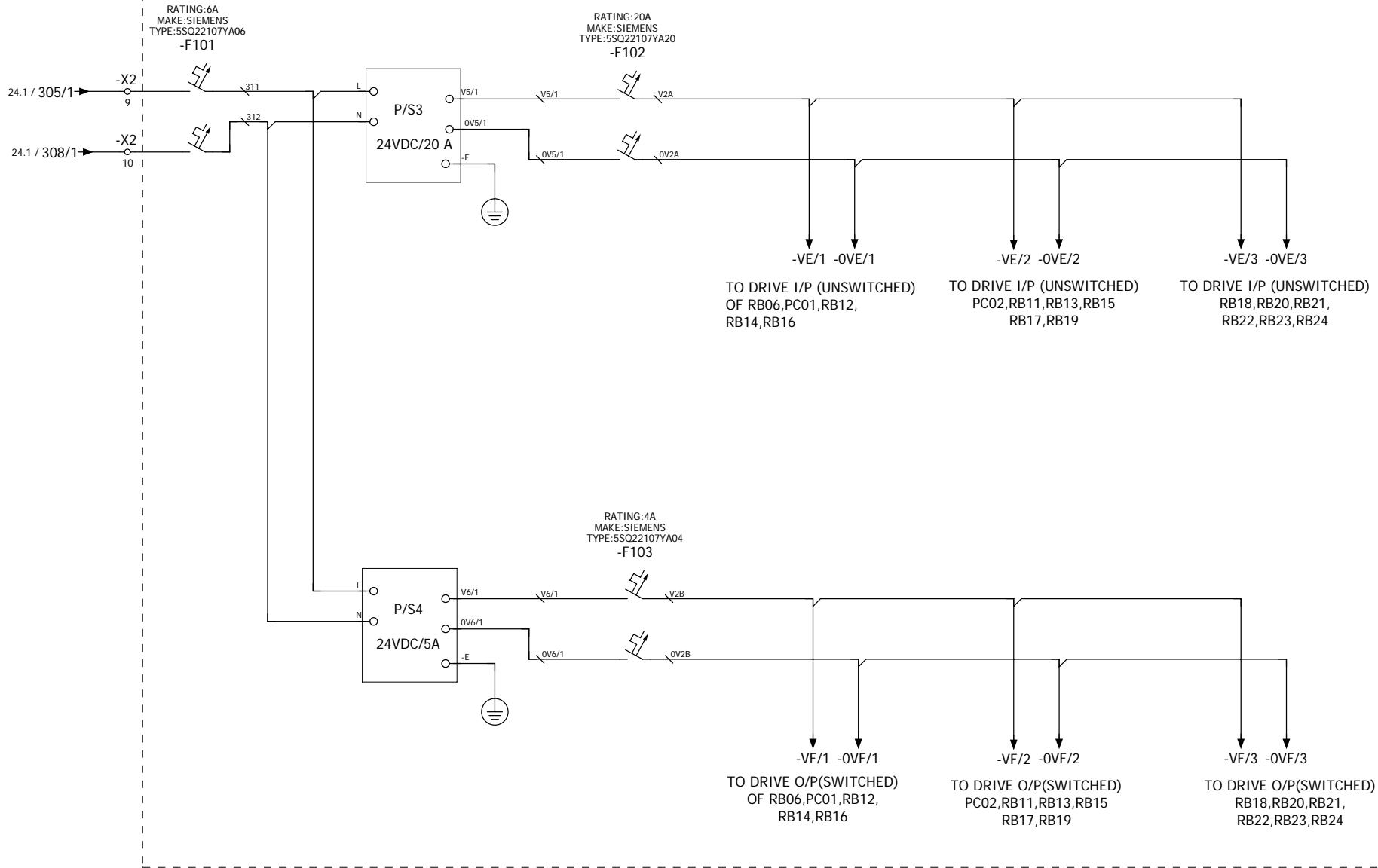

DOCUMENT ID : CY/DD/R/07
REV : 00

CYBERNETIK TECHNOLOGIES PVT.LTD, PUNE

| | | |
|----------|------|--------|
| DRAWN | Date | Name |
| CHECKED | | SHITAL |
| APPROVED | | |

PROJECT DESCRIPTION
HA-382 VOLVO FRANCE

TITLE
CONTROL CKT-3

PROJECT CODE:- **HA-382**

DRAWING NUMBER :-

| | |
|-------|------|
| Page | 24.a |
| Pages | 147 |

TO FIELD

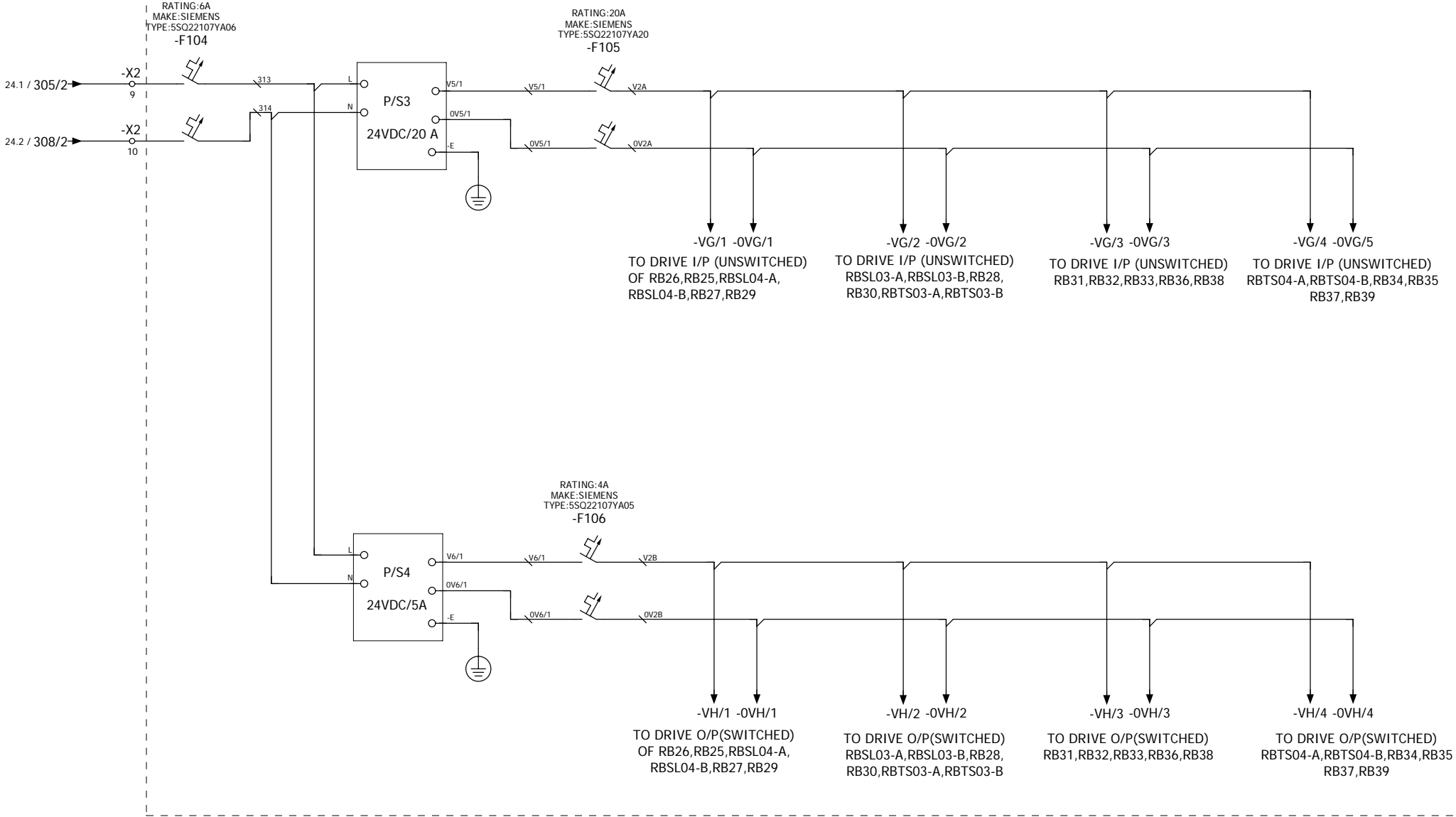

DOCUMENT ID : CY/DD/R/07
 REV : 00

| | | |
|----------|------|--------|
| DRAWN | Date | Name |
| CHECKED | | SHITAL |
| APPROVED | | |

| |
|---------------------|
| PROJECT DESCRIPTION |
| HA-382 VOLVO FRANCE |

| |
|---------------|
| TITLE |
| CONTROL CKT-4 |

| | |
|-------------------|---------------|
| PROJECT CODE :- | HA-382 |
| DRAWING NUMBER :- | |
| Page | 24.b |
| Pages | 147 |

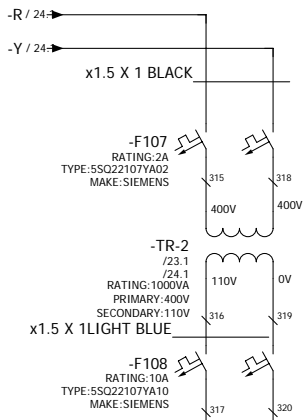

TO FIELD

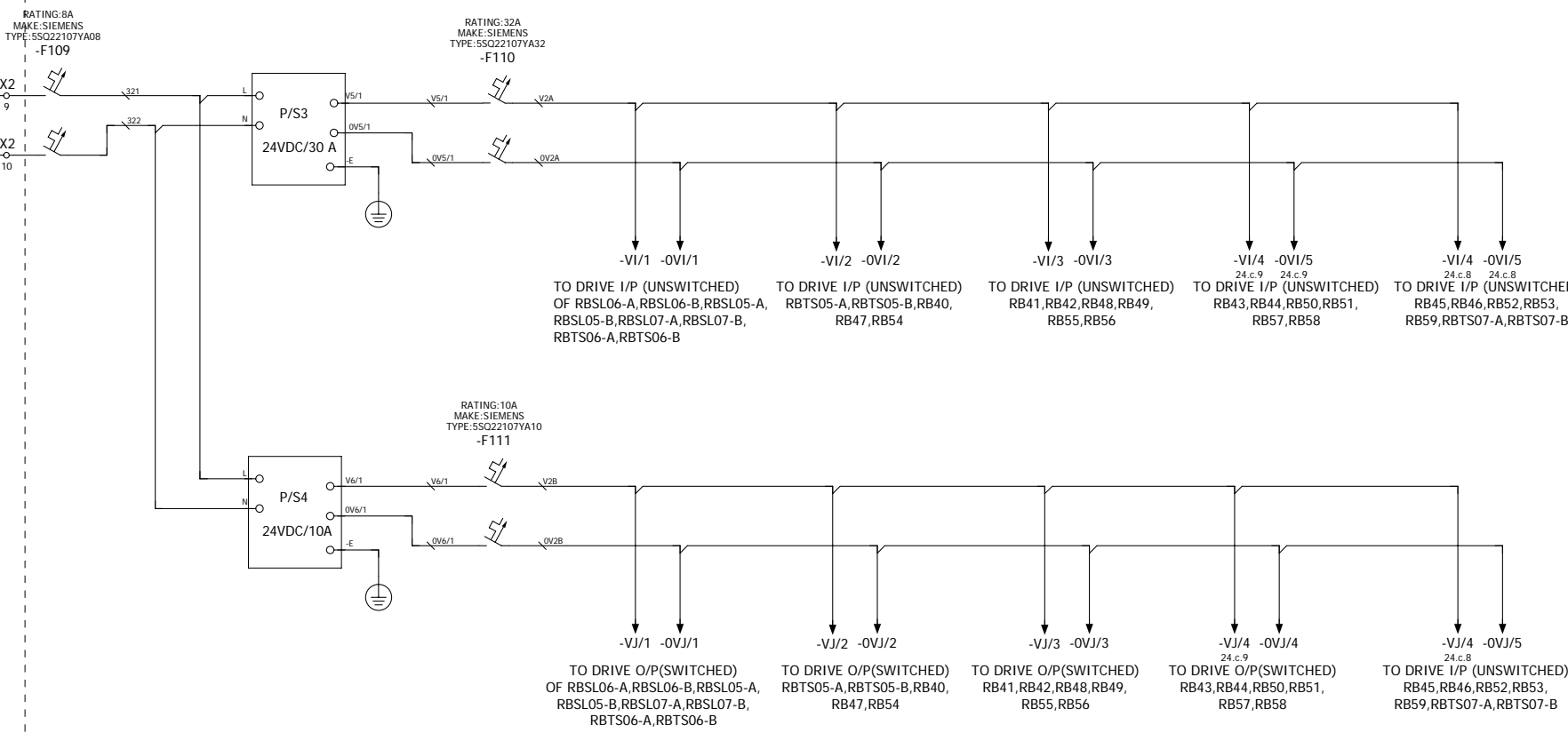

DOCUMENT ID : CY/DD/R/07
REV : 00

CYBERNETIK TECHNOLOGIES
PVT.LTD, PUNE

| | | |
|----------|------|--------|
| DRAWN | Date | Name |
| CHECKED | | SHITAL |
| APPROVED | | |

PROJECT DESCRIPTION
HA-382 VOLVO FRANCE

TITLE
CONTROL CKT-5

| | |
|-------------------|------------------------|
| PROJECT CODE :- | HA-382 |
| DRAWING NUMBER :- | Page 24.c Pages 147 |

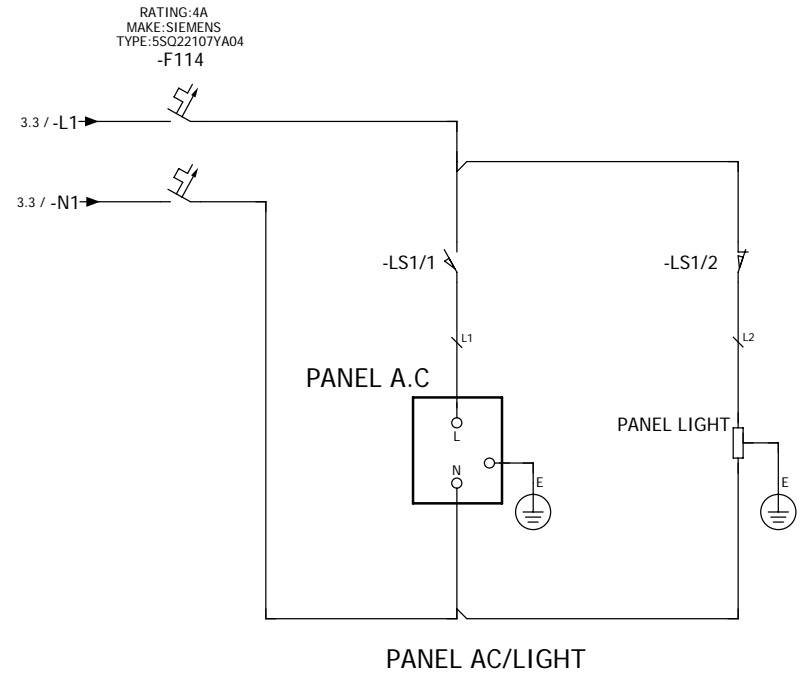
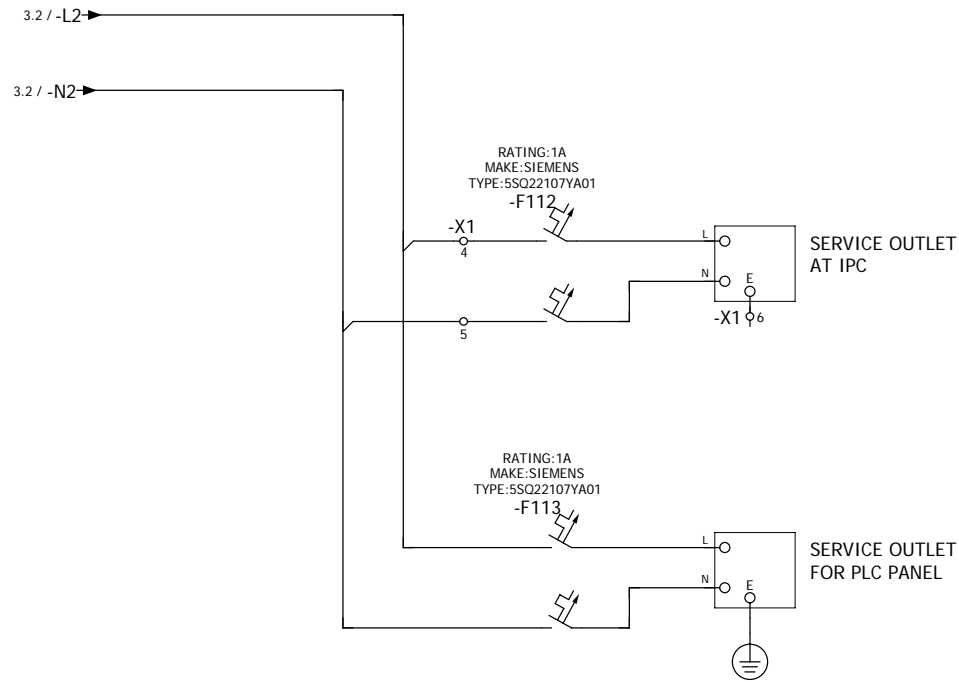

DOCUMENT ID : CY/DD/R/07
REV : 00

 CYBERNETIK TECHNOLOGIES
PVT.LTD, PUNE

| | | |
|----------|------|--------|
| Drawn | Date | Name |
| CHECKED | | SHITAL |
| APPROVED | | |

PROJECT DESCRIPTION
HA-382 VOLVO FRANCE

TITLE
CONTROL CKT-

PROJECT CODE:- **HA-382**

DRAWING NUMBER :-

ZONE-1

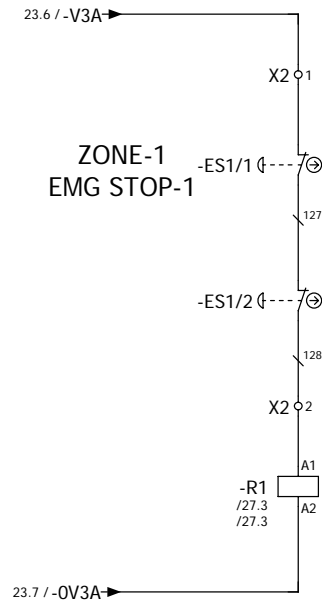

DOCUMENT ID : CY/DD/R/07
 REV : 00

 CYBERNETIK TECHNOLOGIES
 PVT.LTD, PUNE

| | Date | Name |
|----------|------|--------|
| DRAWN | | SHITAL |
| CHECKED | | |
| APPROVED | | |

PROJECT DESCRIPTION
 HA-382 VOLVO FRANCE

TITLE
 ZONE-1 EMG SAFETY

| | |
|-------------------|---------------|
| PROJECT CODE:- | HA-382 |
| DRAWING NUMBER :- | |
| Page | 26 |
| Pages | 147 |

ZONE-1

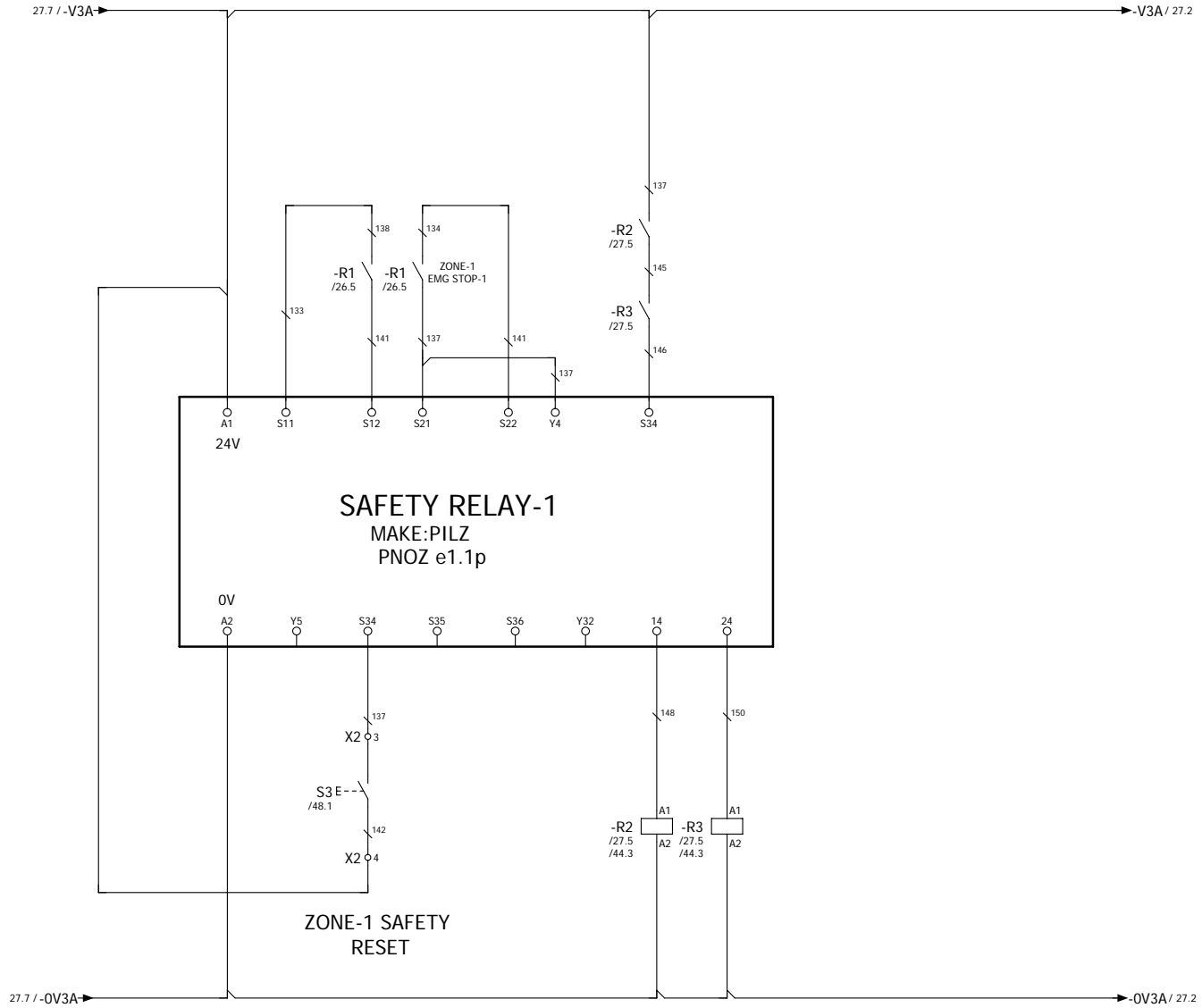

DOCUMENT ID : CY/DD/R/07
 REV : 00

CYBERNETIK TECHNOLOGIES
 PVT.LTD, PUNE

| | | |
|----------|------|--------|
| Drawn | Date | Name |
| CHECKED | | SHITAL |
| APPROVED | | |

PROJECT DESCRIPTION
 HA-382 VOLVO FRANCE

TITLE
 ZONE-1 SAFETY RELAY

| | |
|-------------------|---------------|
| PROJECT CODE:- | HA-382 |
| DRAWING NUMBER :- | |
| Page | 27 |
| Pages | 147 |

ZONE-1-LIGHT CURTAIN-1

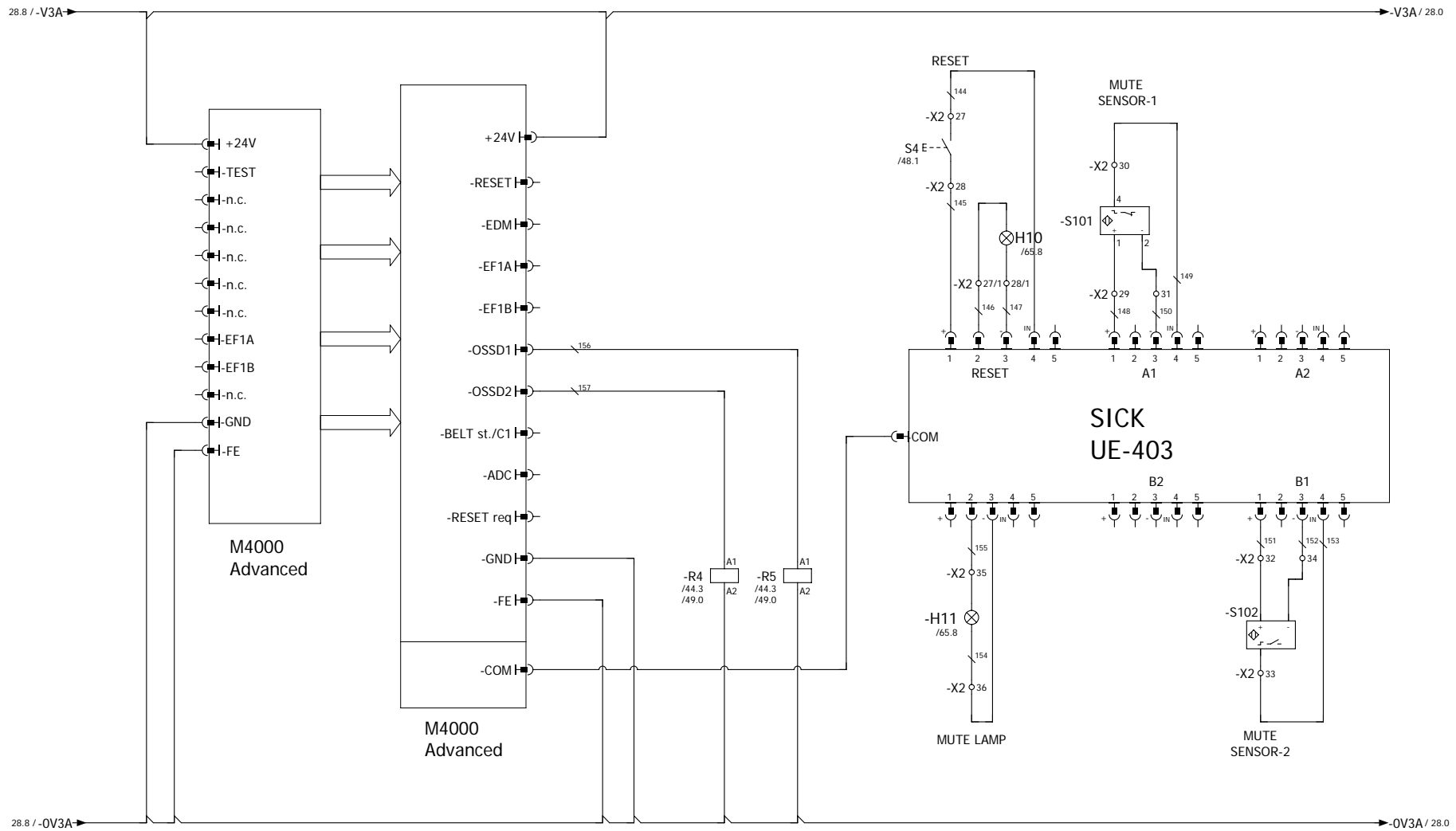

DOCUMENT ID : CY/DD/R/07
REV : 00



CYBERNETIK TECHNOLOGIES
PVT.LTD, PUNE

| | Date | Name |
|----------|------|--------|
| DRAWN | | SHITAL |
| CHECKED | | |
| APPROVED | | |

| PROJECT DESCRIPTION | TITLE |
|---------------------|-------|
| HA-382 VOLVO FRANCE | LC-1 |

| PROJECT CODE:- | DRAWING NUMBER :- |
|----------------|-------------------|
| HA-382 | |

| | |
|-------|-----|
| Page | 28 |
| Pages | 147 |

ZONE-1-LIGHT CURTAIN-2

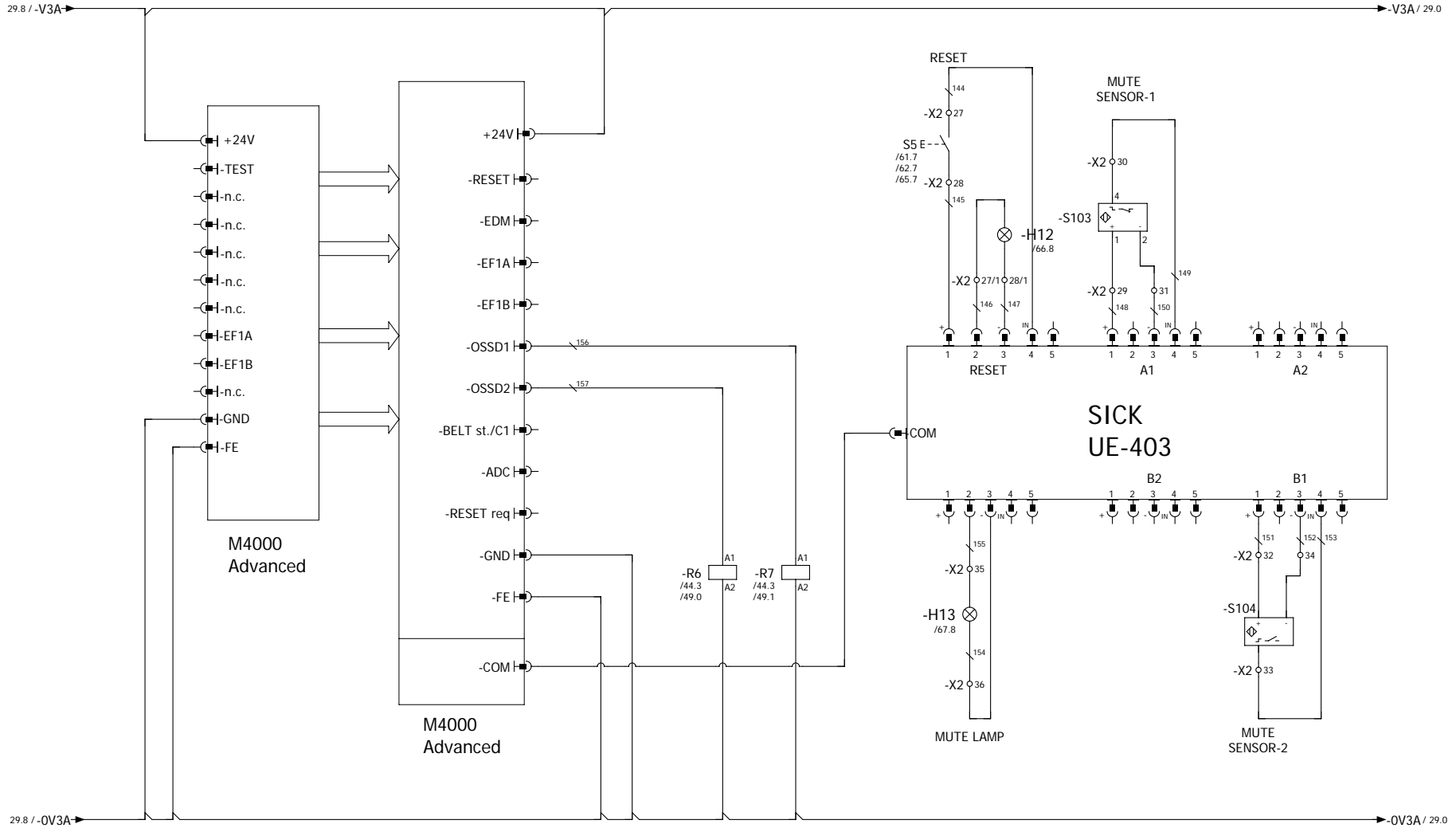

DOCUMENT ID : CY/DD/R/07
REV : 00



CYBERNETIK TECHNOLOGIES
PVT.LTD, PUNE

| | | |
|----------|------|--------|
| DRAWN | Date | Name |
| CHECKED | | SHITAL |
| APPROVED | | |

PROJECT DESCRIPTION
HA-382 VOLVO FRANCE

TITLE
LC-2

PROJECT CODE :- **HA-382**
DRAWING NUMBER :-

ZONE-1-LIGHT CURTAIN-3

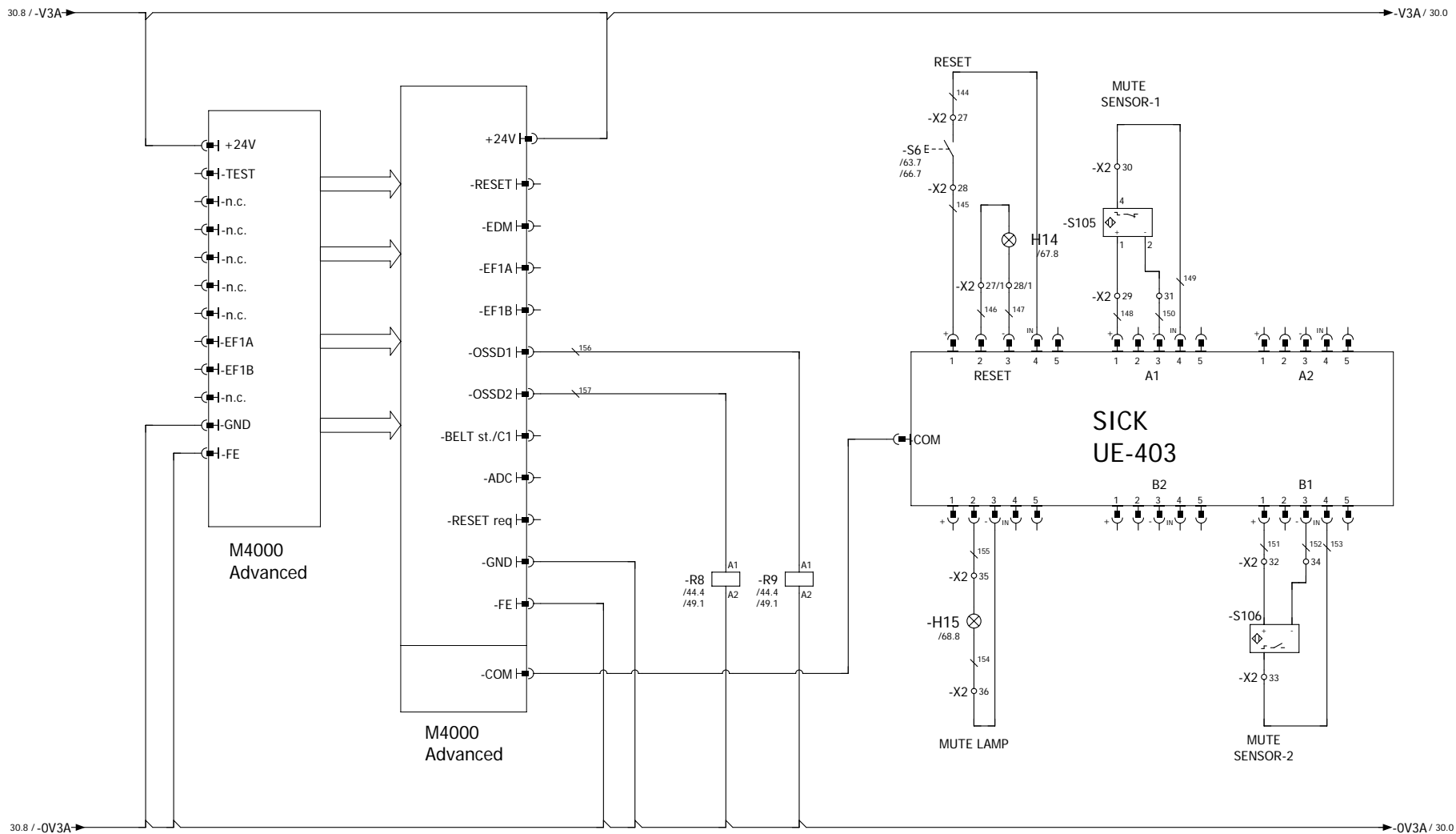

| | | |
|----------|------|--------|
| DRAWN | Date | Name |
| CHECKED | | SHITAL |
| APPROVED | | |

| | |
|---------------------|-------|
| PROJECT DESCRIPTION | TITLE |
| HA-382 VOLVO FRANCE | LC-3 |

| | |
|-------------------|--------|
| PROJECT CODE :- | HA-382 |
| DRAWING NUMBER :- | |

| | |
|-------|-----|
| Page | 30 |
| Pages | 147 |

ZONE-1-LIGHT CURTAIN-4

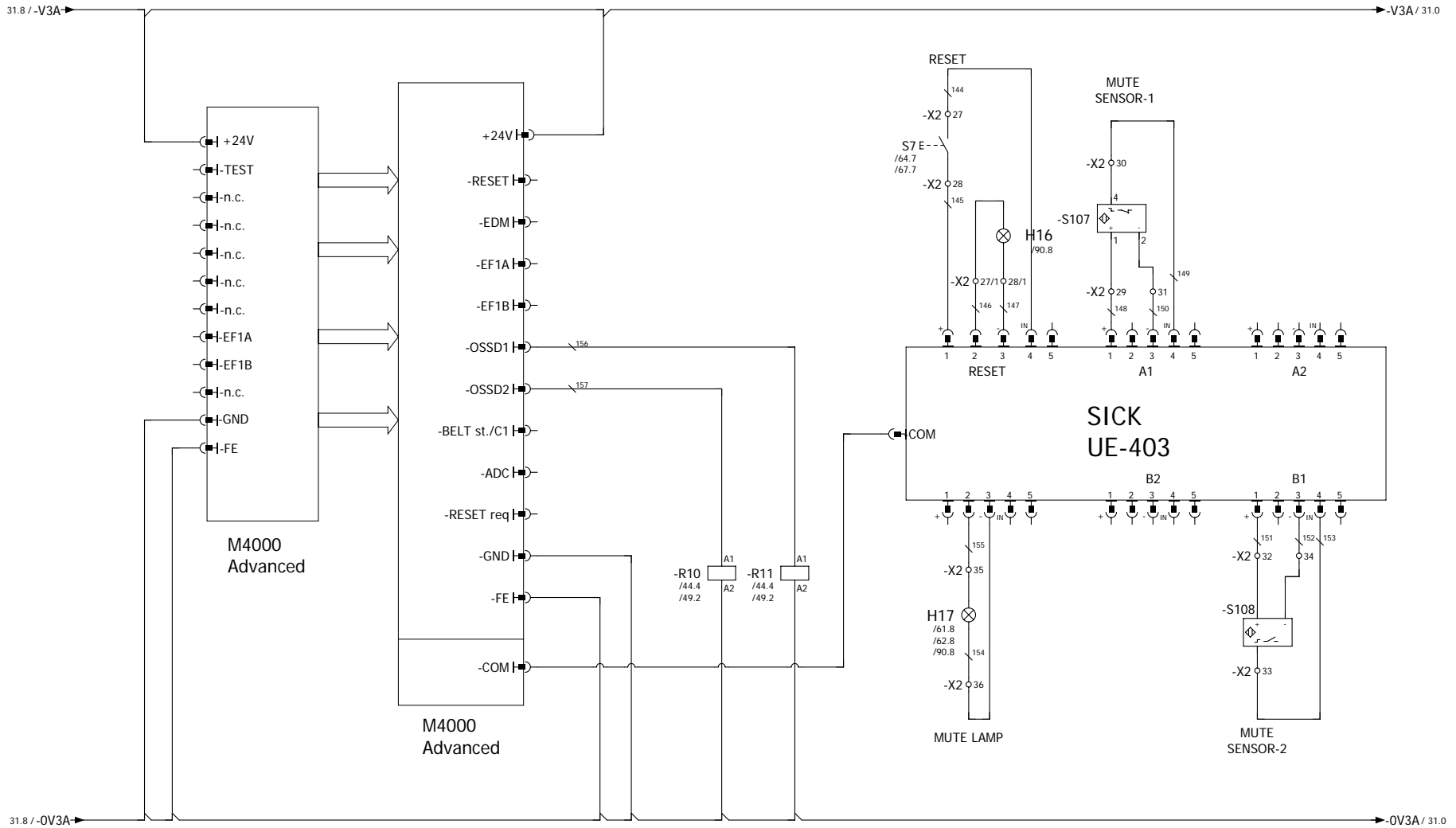

DOCUMENT ID : CY/DD/R/07
REV : 00



CYBERNETIK TECHNOLOGIES
PVT.LTD, PUNE

| | Date | Name |
|----------|------|--------|
| DRAWN | | SHITAL |
| CHECKED | | |
| APPROVED | | |

| PROJECT DESCRIPTION | TITLE |
|---------------------|-------|
| HA-382 VOLVO FRANCE | LC-4 |

| PROJECT CODE :- | DRAWING NUMBER :- |
|-----------------|-------------------|
| HA-382 | |

| | |
|-------|-----|
| Page | 31 |
| Pages | 147 |

ZONE-1-LIGHT CURTAIN-5

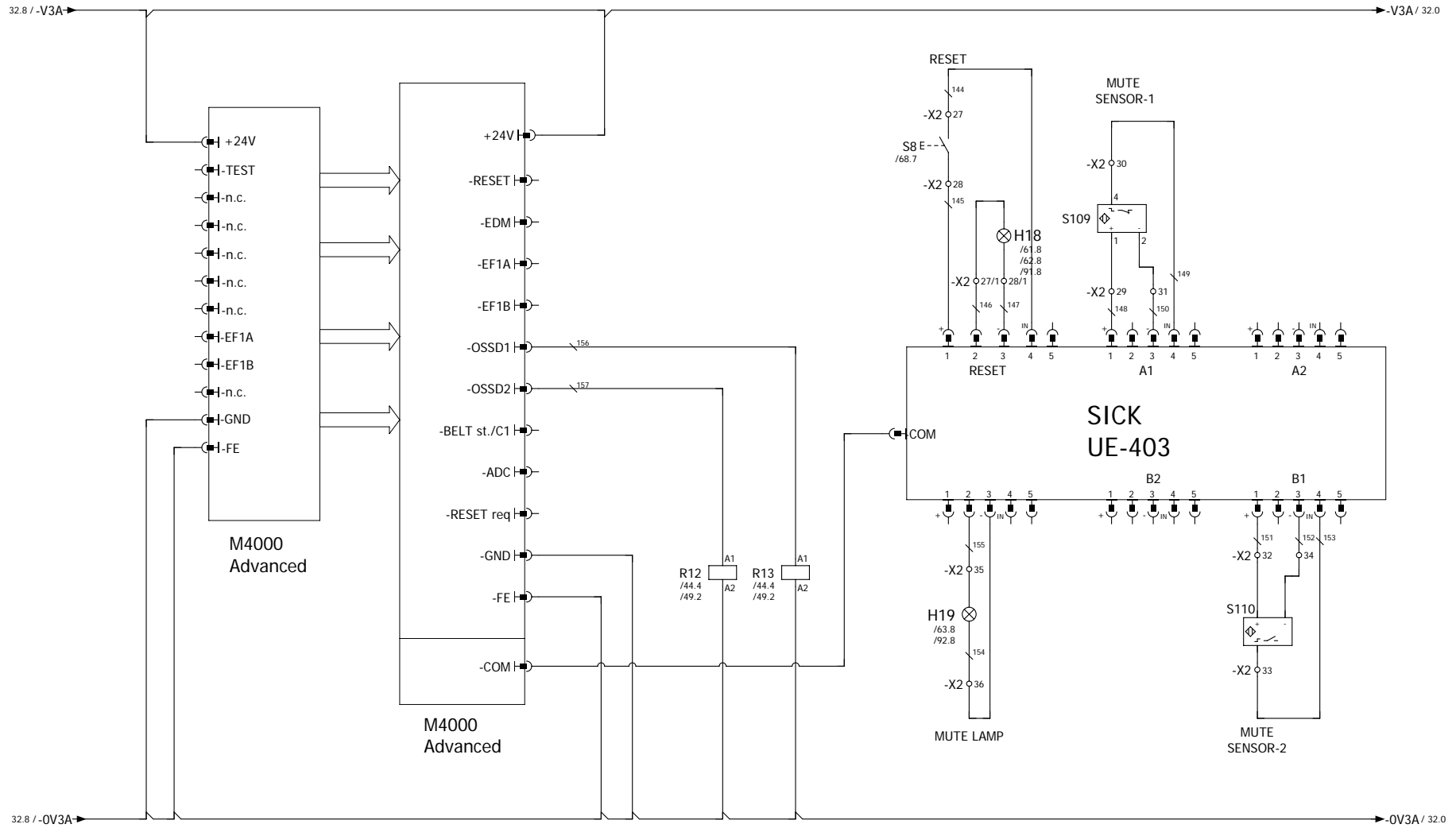

DOCUMENT ID : CY/DD/R/07
REV : 00



CYBERNETIK TECHNOLOGIES
PVT.LTD, PUNE

| | Date | Name |
|----------|------|--------|
| DRAWN | | SHITAL |
| CHECKED | | |
| APPROVED | | |

PROJECT DESCRIPTION
HA-382 VOLVO FRANCE

TITLE
LC-5

PROJECT CODE :- **HA-382**
DRAWING NUMBER :-

ZONE-2

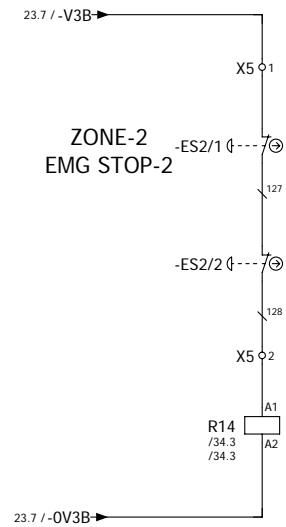

DOCUMENT ID : CY/DD/R/07
 REV : 00

 CYBERNETIK TECHNOLOGIES
 PVT.LTD, PUNE

| | | |
|----------|------|--------|
| Drawn | Date | Name |
| CHECKED | | SHITAL |
| APPROVED | | |

PROJECT DESCRIPTION
 HA-382 VOLVO FRANCE

TITLE
 ZONE-2 EMG SAFETY

PROJECT CODE:- **HA-382**
 DRAWING NUMBER :-

ZONE-2

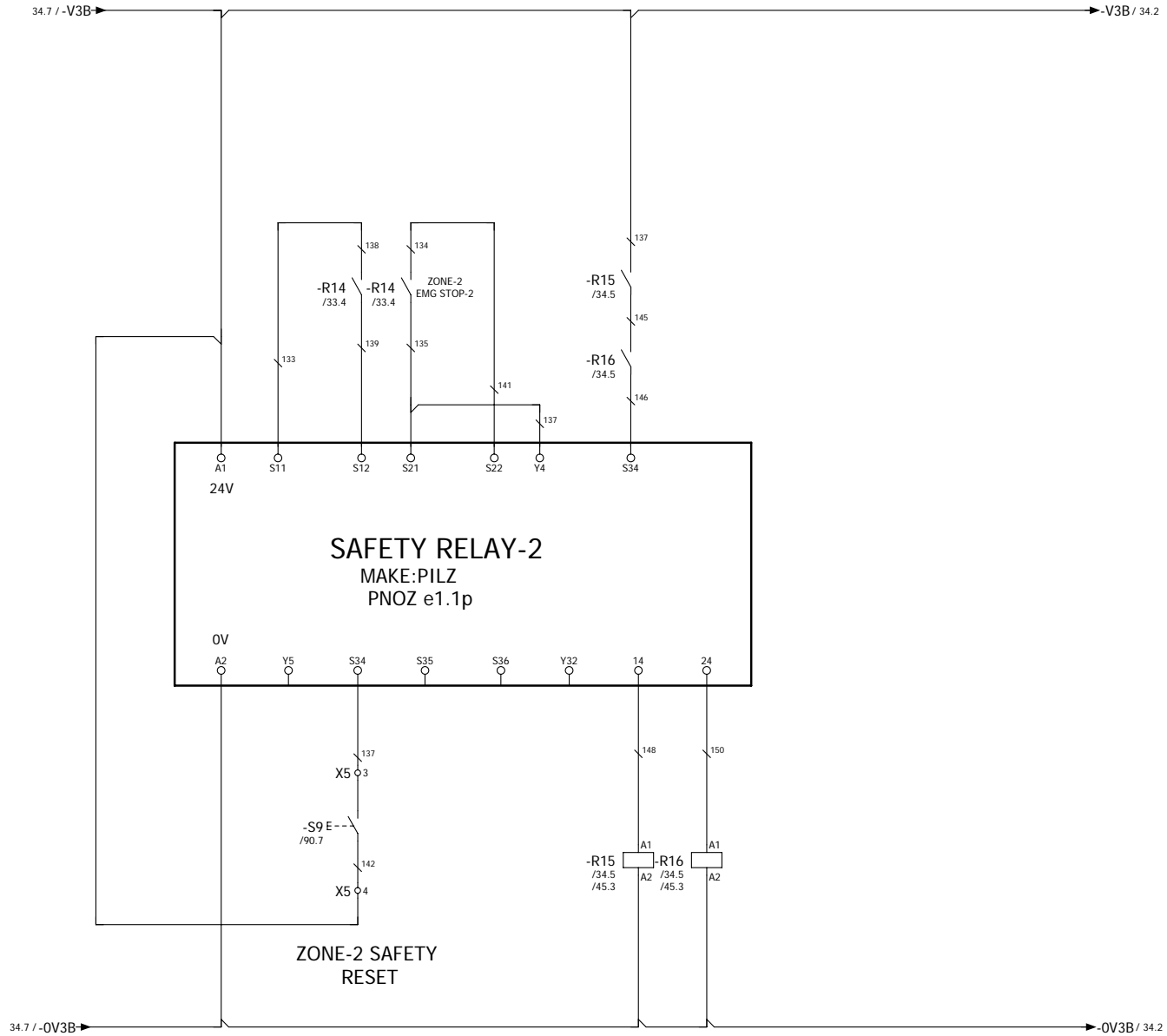

DOCUMENT ID : CY/DD/R/07
REV : 00



CYBERNETIK TECHNOLOGIES
PVT.LTD, PUNE

| | | |
|----------|------|--------|
| Drawn | Date | Name |
| CHECKED | | SHITAL |
| APPROVED | | |

PROJECT DESCRIPTION
HA-382 VOLVO FRANCE

TITLE
ZONE-2 SAFETY RELAY

| | |
|-------------------|---------------|
| PROJECT CODE :- | HA-382 |
| DRAWING NUMBER :- | |
| Page | 34 |
| Pages | 147 |

ZONE-3

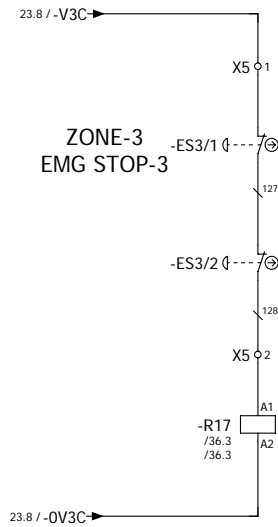

DOCUMENT ID : CY/DD/R/07
REV : 00



CYBERNETIK TECHNOLOGIES
PVT.LTD, PUNE

| | Date | Name |
|----------|------|--------|
| DRAWN | | SHITAL |
| CHECKED | | |
| APPROVED | | |

| PROJECT DESCRIPTION | TITLE |
|---------------------|-------------------|
| HA-382 VOLVO FRANCE | ZONE-3 EMG SAFETY |

| PROJECT CODE:- | TITLE |
|----------------|-------------------|
| HA-382 | ZONE-3 EMG SAFETY |

| DRAWING NUMBER :- | Page | Pages |
|-------------------|------|-------|
| | 35 | 147 |

ZONE-3

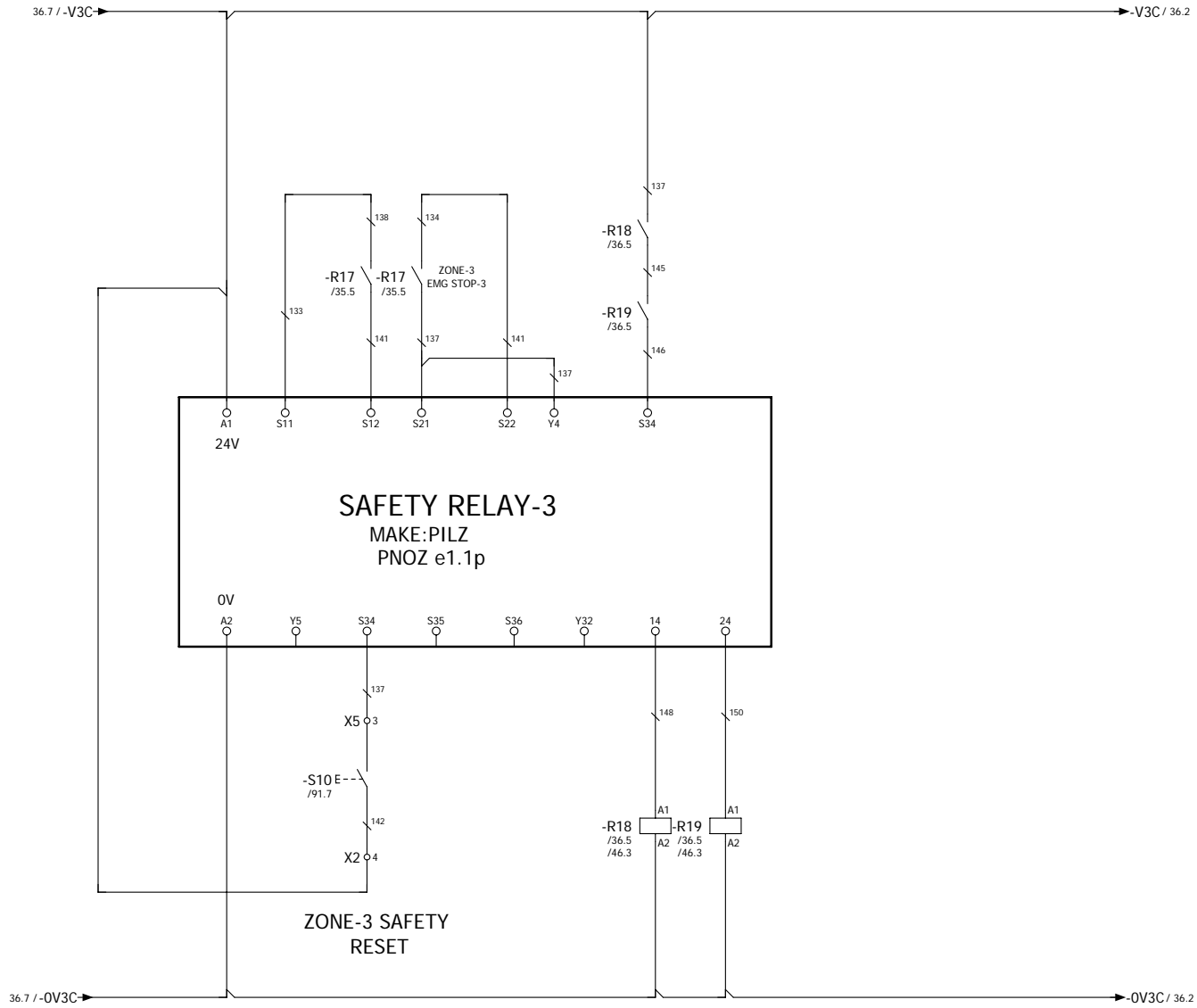

DOCUMENT ID : CY/DD/R/07
REV : 00

 CYBERNETIK TECHNOLOGIES
PVT.LTD, PUNE

| | | |
|----------|------|--------|
| Drawn | Date | Name |
| CHECKED | | SHITAL |
| APPROVED | | |

PROJECT DESCRIPTION
HA-382 VOLVO FRANCE

TITLE
ZONE-3 SAFETY RELAY

| | |
|-------------------|---------------|
| PROJECT CODE :- | HA-382 |
| DRAWING NUMBER :- | |
| Page | 36 |
| Pages | 147 |

ZONE-3 LIGHT CURTAIN-6

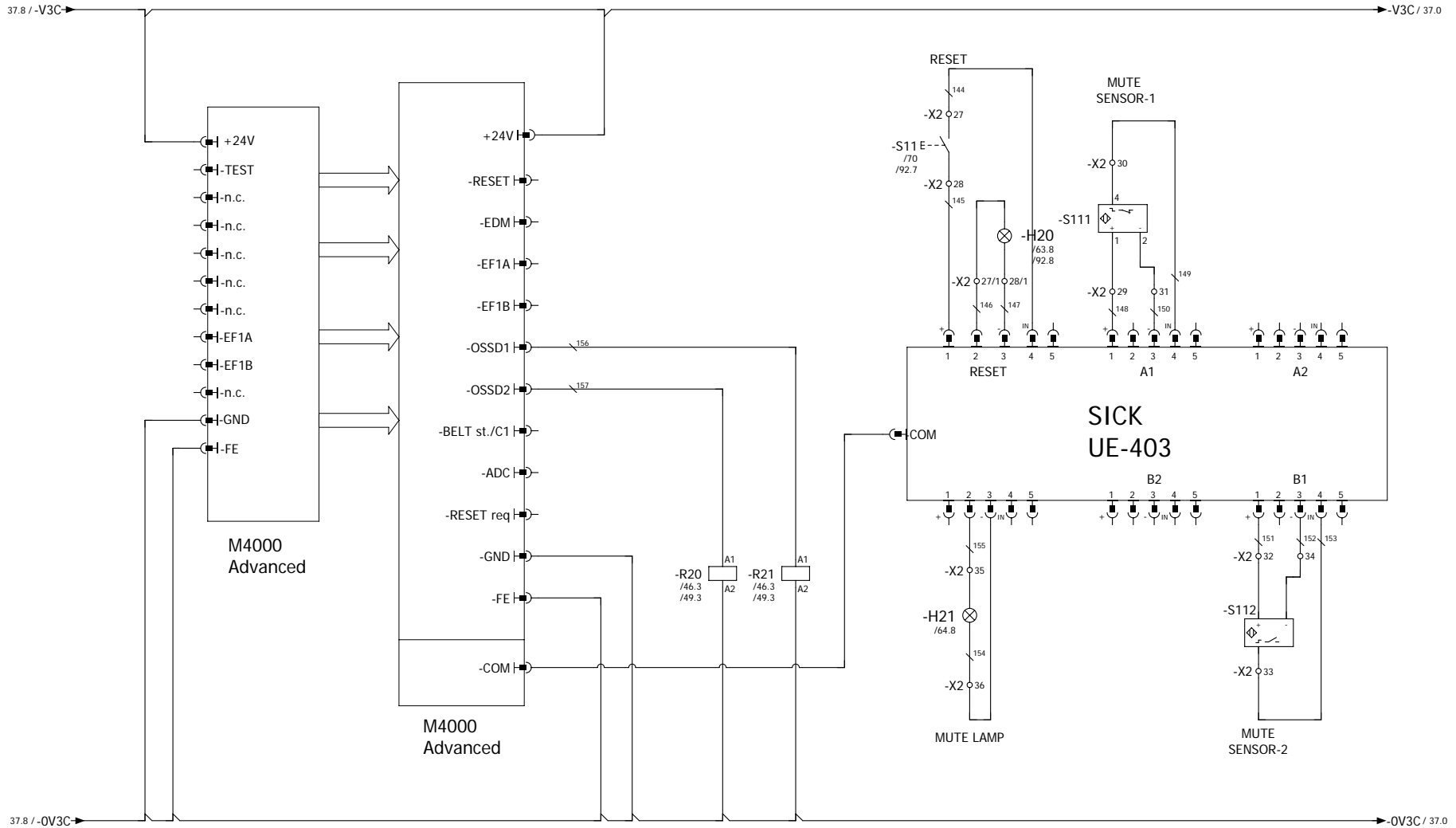

DOCUMENT ID : CY/DD/R/07
REV : 00



CYBERNETIK TECHNOLOGIES
PVT.LTD, PUNE

| | Date | Name |
|----------|------|--------|
| DRAWN | | SHITAL |
| CHECKED | | |
| APPROVED | | |

| PROJECT DESCRIPTION | TITLE |
|---------------------|-------|
| HA-382 VOLVO FRANCE | LC-1 |

| PROJECT CODE :- | DRAWING NUMBER :- |
|-----------------|-------------------|
| HA-382 | |

| | |
|-------|-----|
| Page | 37 |
| Pages | 147 |

ZONE-3 LIGHT CURTAIN-7

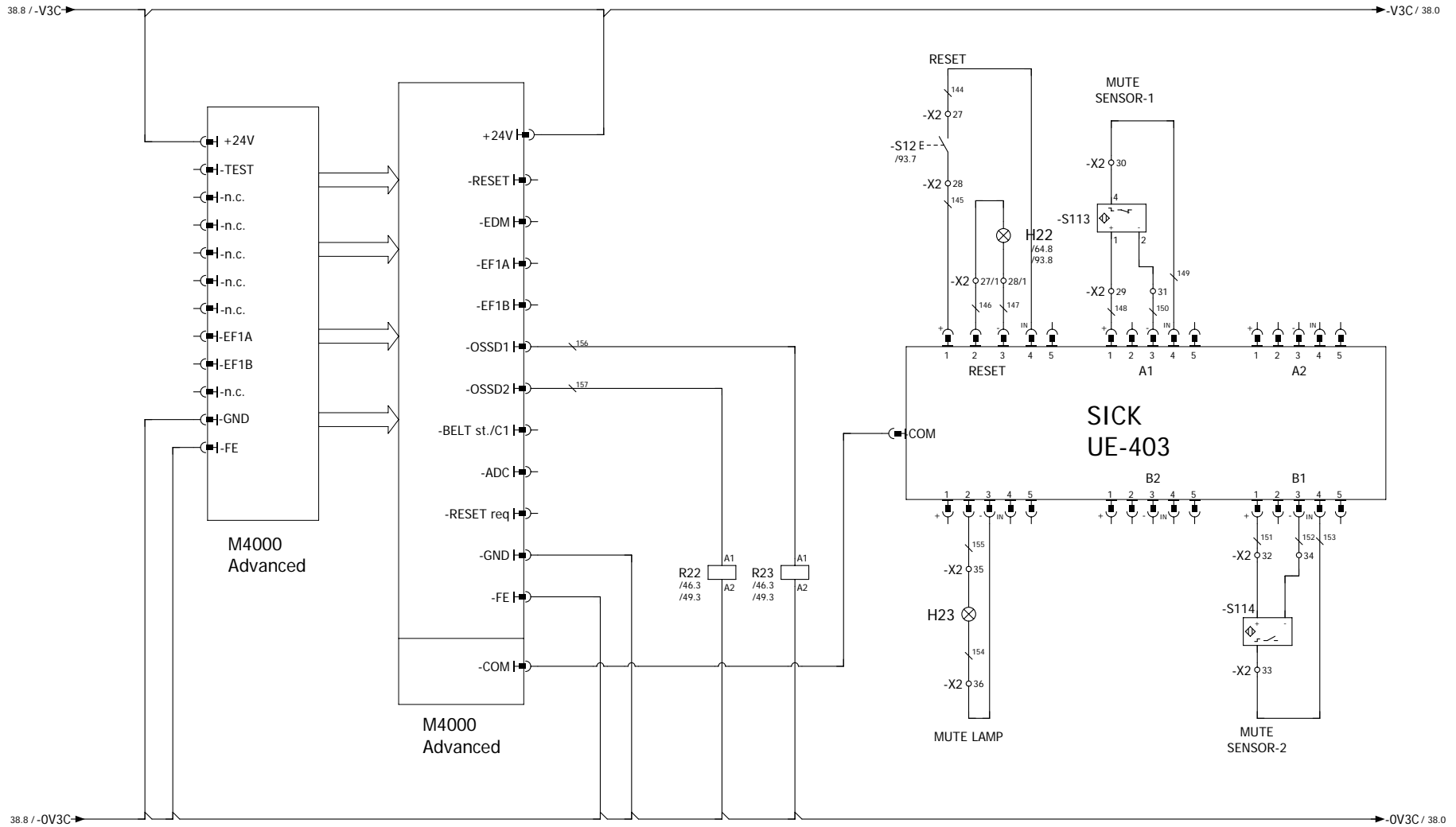

DOCUMENT ID : CY/DD/R/07
REV : 00

CYBERNETIK TECHNOLOGIES PVT.LTD, PUNE

| | Date | Name |
|----------|------|--------|
| DRAWN | | SHITAL |
| CHECKED | | |
| APPROVED | | |

PROJECT DESCRIPTION
HA-382 VOLVO FRANCE

TITLE
LC-2

PROJECT CODE :- HA-382
DRAWING NUMBER :-

ZONE-3 LIGHT CURTAIN-8

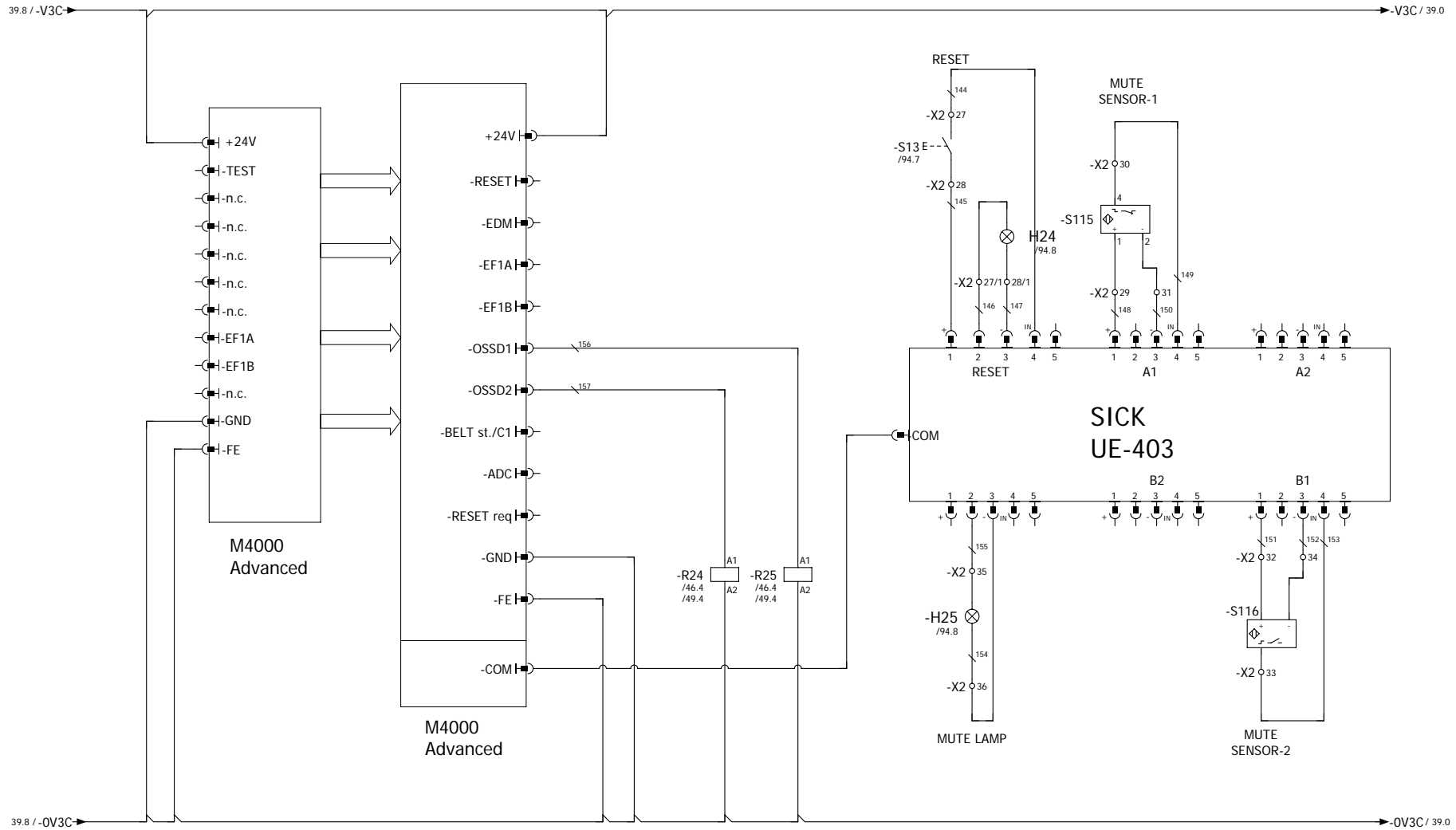

DOCUMENT ID : CY/DD/R/07
REV : 00



CYBERNETIK TECHNOLOGIES
PVT.LTD, PUNE

| | | |
|----------|------|--------|
| DRAWN | Date | Name |
| CHECKED | | SHITAL |
| APPROVED | | |

PROJECT DESCRIPTION
HA-382 VOLVO FRANCE

TITLE
LC-3

PROJECT CODE :- **HA-382**
DRAWING NUMBER :-

ZONE-4 LIGHT CURTAIN-9

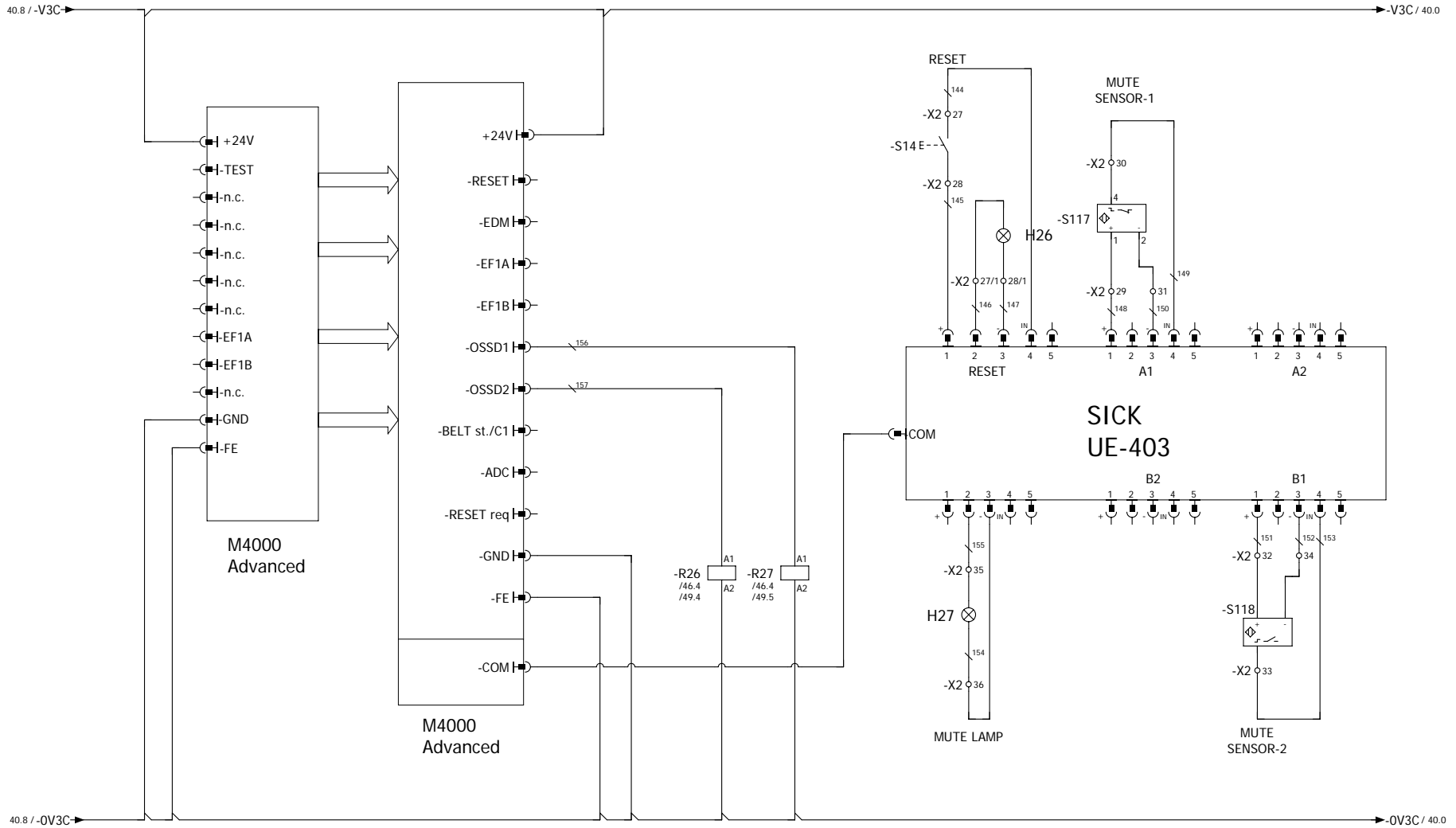

DOCUMENT ID : CY/DD/R/07
REV : 00

CYBERNETIK TECHNOLOGIES PVT.LTD, PUNE

| | | |
|----------|------|--------|
| DRAWN | Date | Name |
| CHECKED | | SHITAL |
| APPROVED | | |

| | |
|---------------------|---------------------|
| PROJECT DESCRIPTION | HA-382 VOLVO FRANCE |
|---------------------|---------------------|

| | |
|-------|------|
| TITLE | LC-4 |
|-------|------|

| | |
|-------------------|---------------|
| PROJECT CODE :- | HA-382 |
| DRAWING NUMBER :- | |
| Page | 40 |
| Pages | 147 |

ZONE-3-LIGHT CURTAIN-10

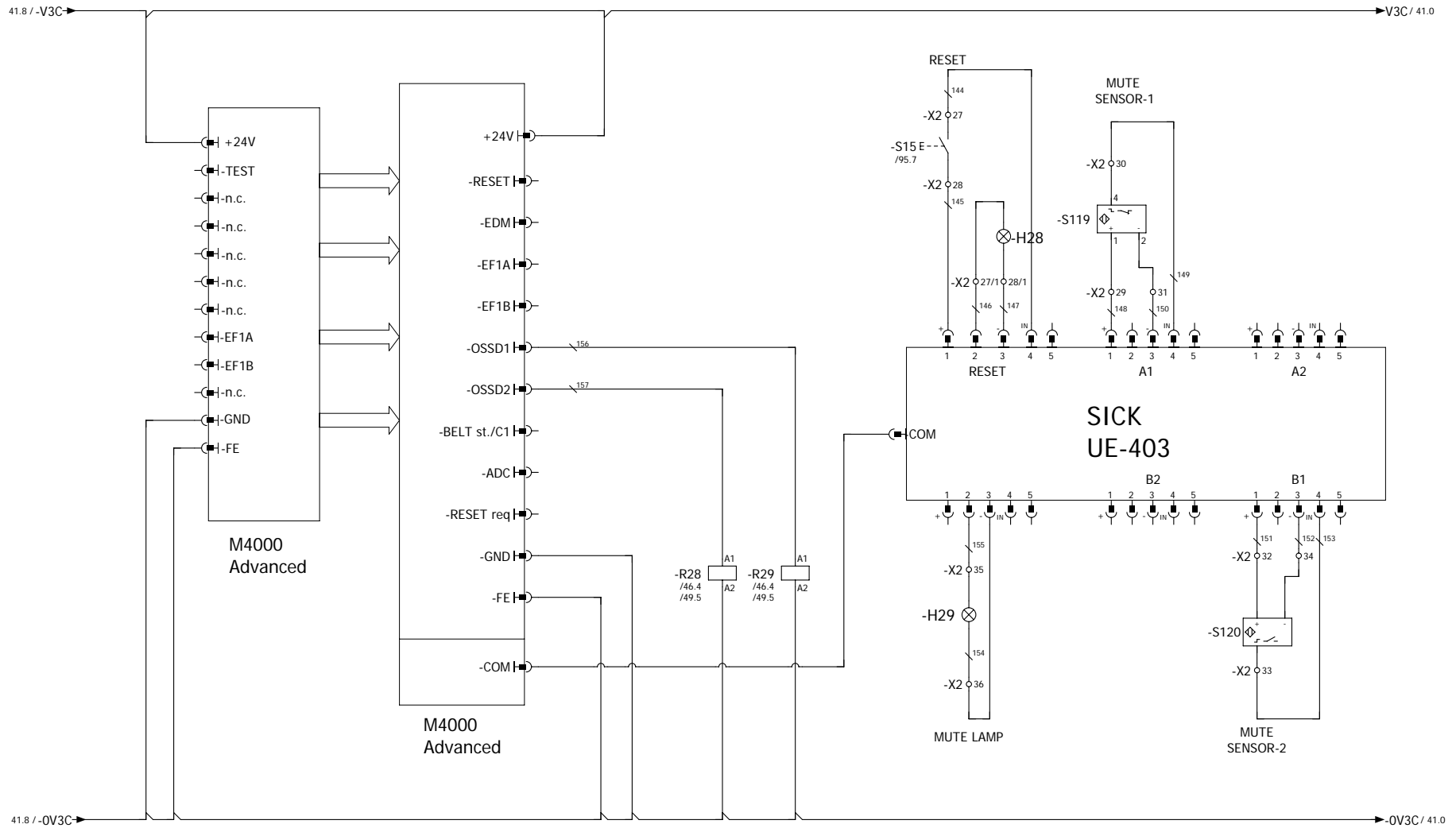

DOCUMENT ID : CY/DD/R/07
REV : 00

CYBERNETIK TECHNOLOGIES
PVT.LTD, PUNE

| | | |
|----------|------|--------|
| DRAWN | Date | Name |
| CHECKED | | SHITAL |
| APPROVED | | |

| | |
|---------------------|---------------------|
| PROJECT DESCRIPTION | HA-382 VOLVO FRANCE |
|---------------------|---------------------|

| | |
|-------|------|
| TITLE | LC-5 |
|-------|------|

| | |
|-------------------|--------|
| PROJECT CODE :- | HA-382 |
| DRAWING NUMBER :- | |
| Page | 41 |
| Pages | 147 |

ZONE-4

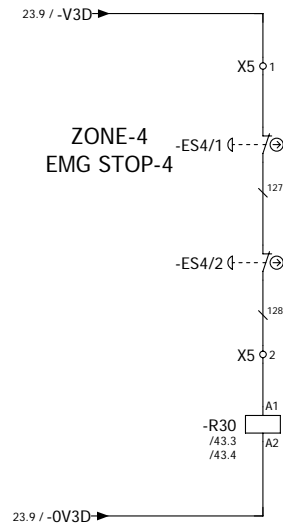

DOCUMENT ID : CY/DD/R/07
 REV : 00

 CYBERNETIK TECHNOLOGIES
 PVT.LTD, PUNE

| | Date | Name |
|----------|------|--------|
| DRAWN | | SHITAL |
| CHECKED | | |
| APPROVED | | |

PROJECT DESCRIPTION
 HA-382 VOLVO FRANCE

TITLE
 ZONE-4 EMG SAFETY

| | |
|-------------------|---------------|
| PROJECT CODE:- | HA-382 |
| DRAWING NUMBER :- | |
| Page | 42 |
| Pages | 147 |

ZONE-4

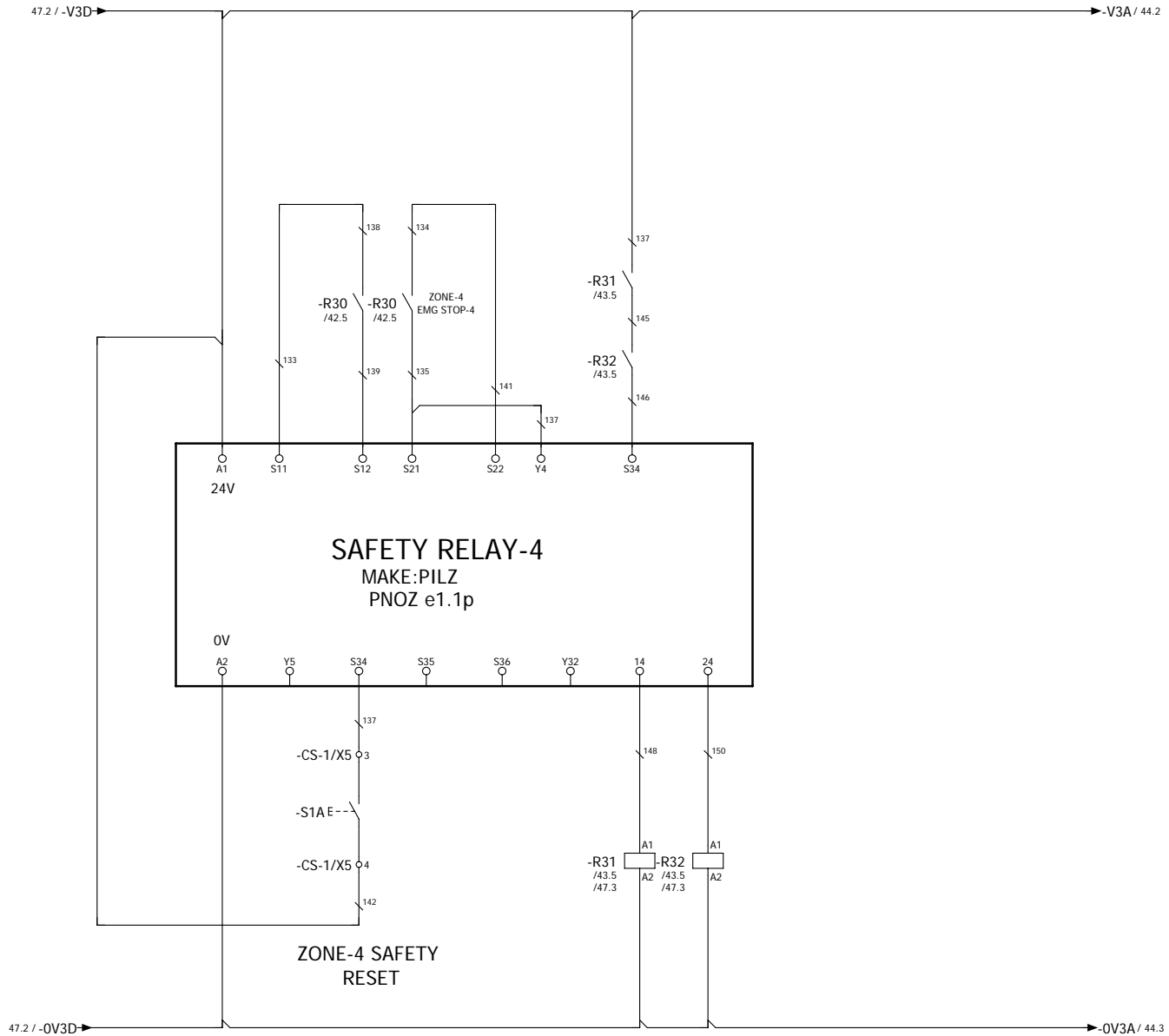

DOCUMENT ID : CY/DD/R/07
REV : 00

CYBERNETIK TECHNOLOGIES PVT.LTD, PUNE

| | | |
|----------|------|--------|
| Drawn | Date | Name |
| Checked | | SHITAL |
| Approved | | |

PROJECT DESCRIPTION
HA-382 VOLVO FRANCE

TITLE
ZONE-4 SAFETY RELAY

| | |
|-------------------|---------------|
| PROJECT CODE :- | HA-382 |
| DRAWING NUMBER :- | |
| Page | 43 |
| Pages | 147 |

ZONE-1

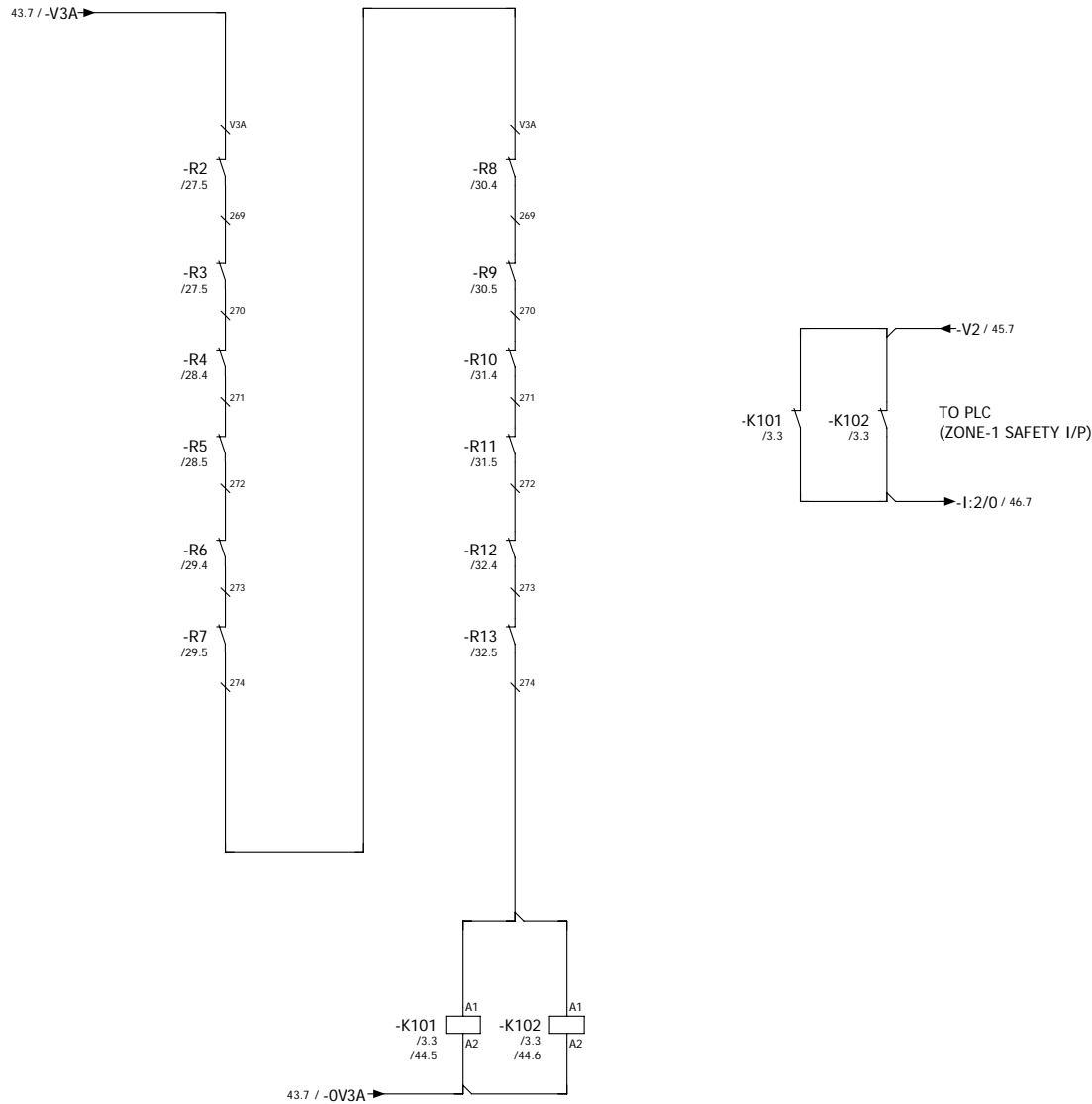

DOCUMENT ID : CY/DD/R/07
REV : 00

CYBERNETIK TECHNOLOGIES
PVT.LTD, PUNE

| | Date | Name |
|----------|------|--------|
| DRAWN | | SHITAL |
| CHECKED | | |
| APPROVED | | |

PROJECT DESCRIPTION
HA-382 VOLVO FRANCE

TITLE
ZONE-1

PROJECT CODE:- **HA-382**

DRAWING NUMBER :-

ZONE-2

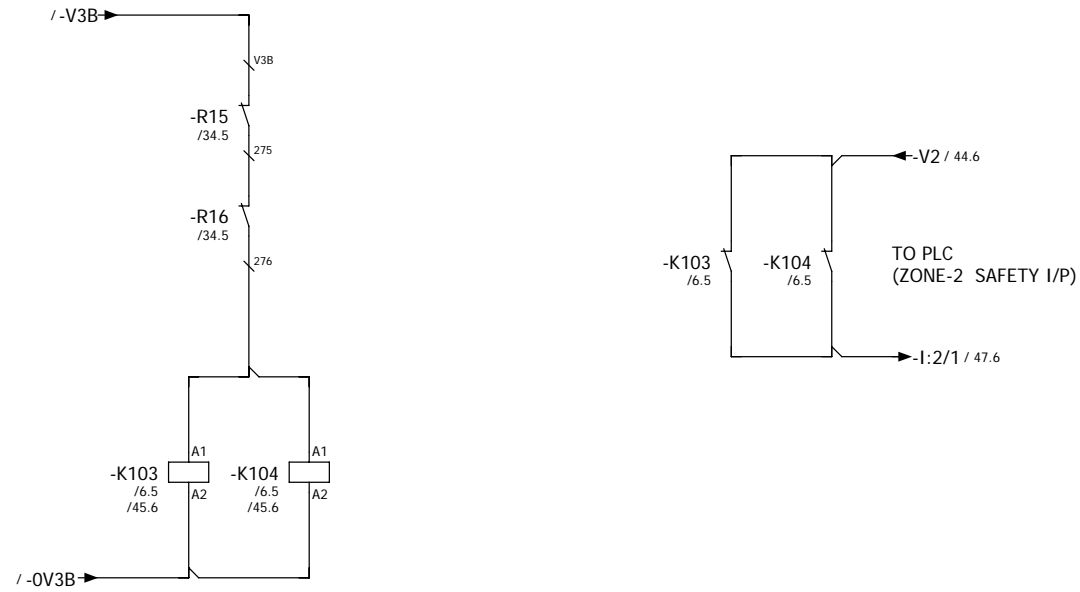

DOCUMENT ID : CY/DD/R/07
REV : 00



CYBERNETIK TECHNOLOGIES
PVT.LTD, PUNE

| | | |
|----------|------|--------|
| DRAWN | Date | Name |
| CHECKED | | SHITAL |
| APPROVED | | |

PROJECT DESCRIPTION
HA-382 VOLVO FRANCE

TITLE
ZONE-2

| | |
|-------------------|---------------|
| PROJECT CODE:- | HA-382 |
| DRAWING NUMBER :- | |
| Page | 45 |
| Pages | 147 |

ZONE-3

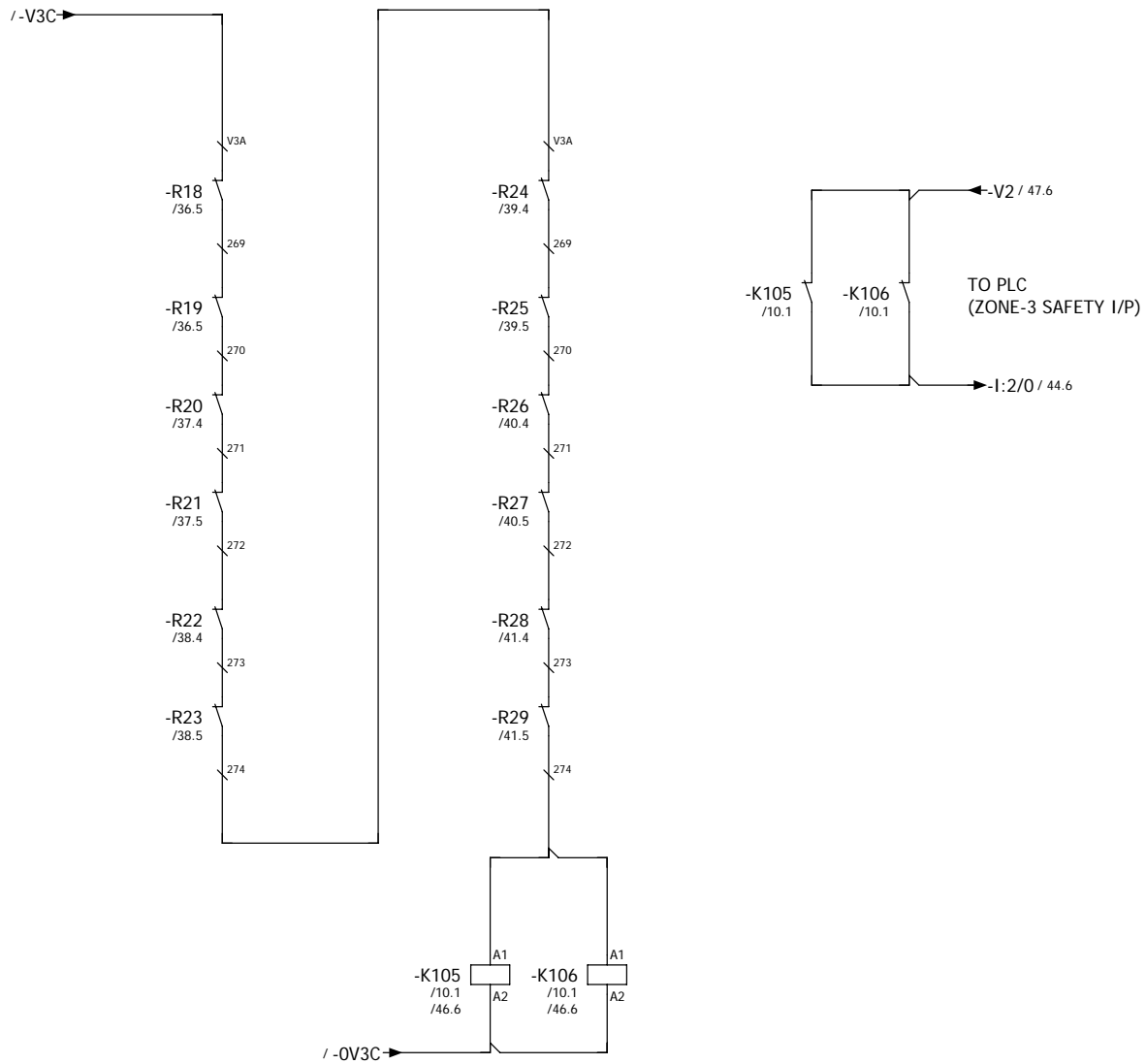

DOCUMENT ID : CY/DD/R/07
REV : 00

 CYBERNETIK TECHNOLOGIES
PVT.LTD, PUNE

| | | |
|----------|------|--------|
| | Date | Name |
| DRAWN | | SHITAL |
| CHECKED | | |
| APPROVED | | |

PROJECT DESCRIPTION
HA-382 VOLVO FRANCE

TITLE
ZONE-3

| | |
|-------------------|---------------|
| PROJECT CODE:- | HA-382 |
| DRAWING NUMBER :- | |
| Page | 46 |
| Pages | 147 |

ZONE-2

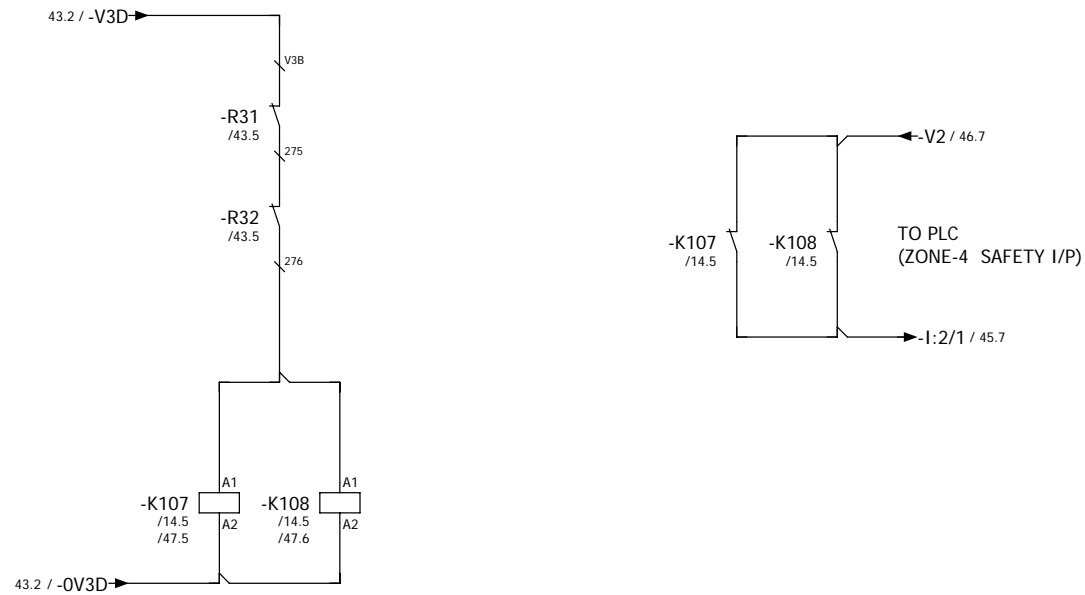

| | Date | Name |
|----------|------|--------|
| DRAWN | | SHITAL |
| CHECKED | | |
| APPROVED | | |

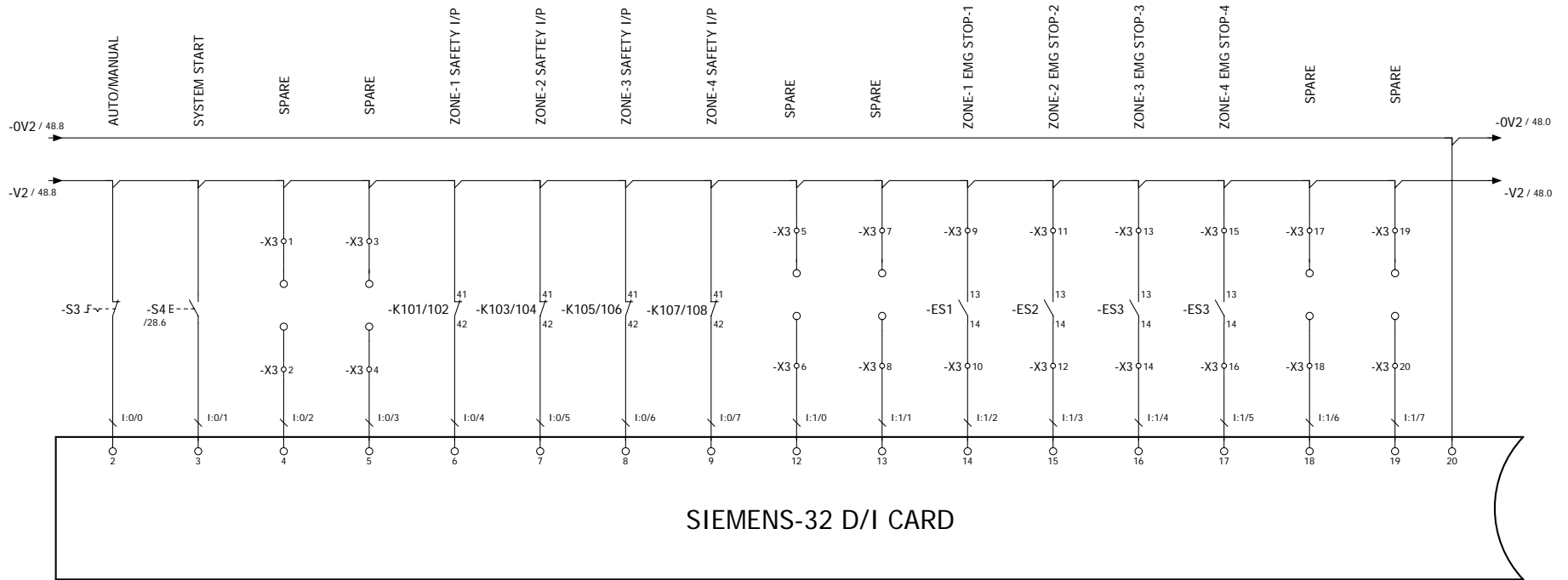

DOCUMENT ID : CY/DD/R/07
REV : 00



CYBERNETIK TECHNOLOGIES
PVT.LTD, PUNE

| | | |
|----------|------|--------|
| Drawn | Date | Name |
| CHECKED | | SHITAL |
| APPROVED | | |

PROJECT DESCRIPTION
HA-382 VOLVO FRANCE

TITLE
PLC I/P -1

| | |
|-------------------|---------------|
| PROJECT CODE :- | HA-382 |
| DRAWING NUMBER :- | |
| Page | 48 |
| Pages | 147 |

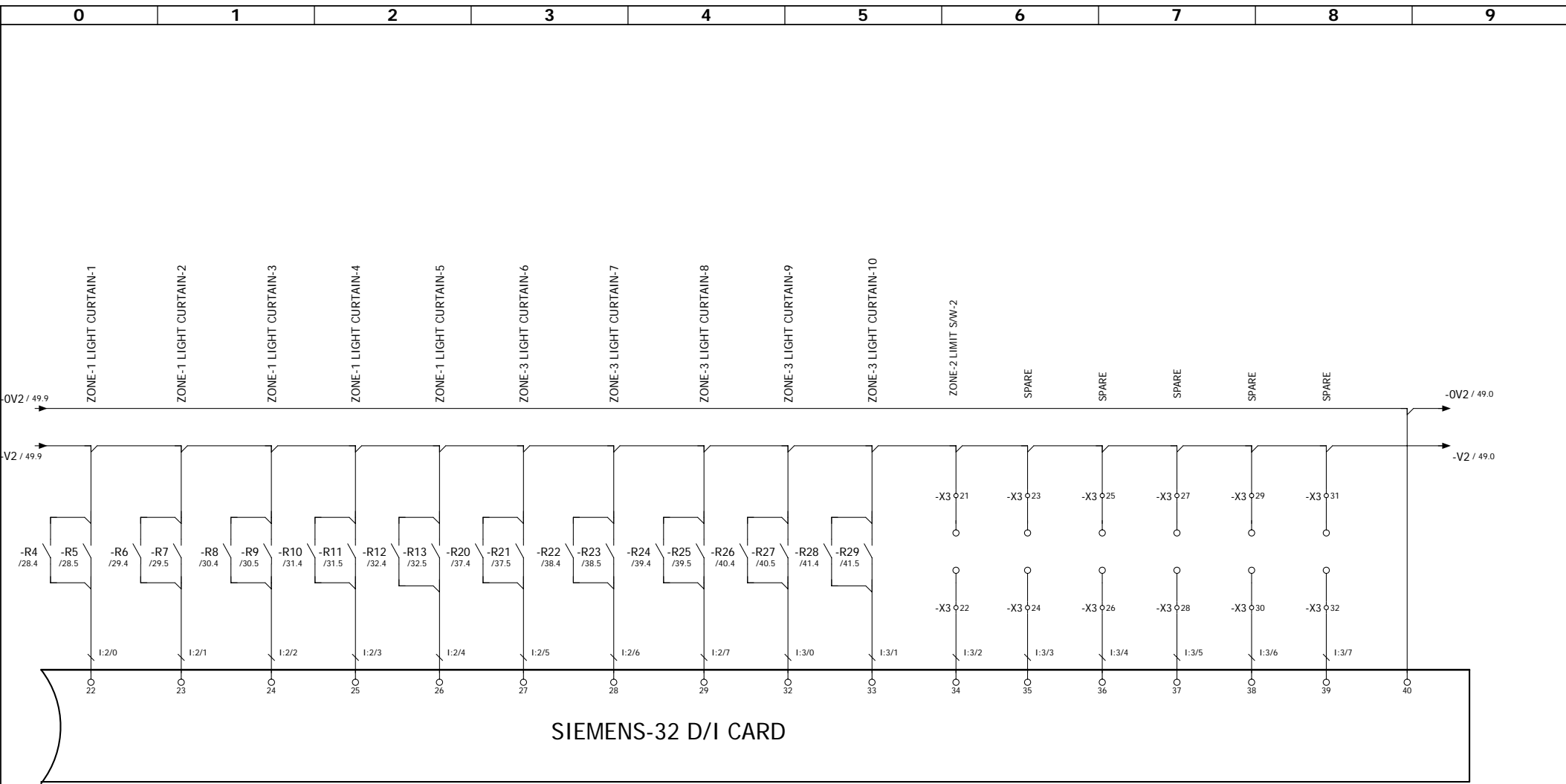

DOCUMENT ID : CY/DD/R/07
REV : 00



CYBERNETIK TECHNOLOGIES
PVT.LTD, PUNE

| | | |
|----------|------|--------|
| Drawn | Date | Name |
| Checked | | SHITAL |
| Approved | | |

PROJECT DESCRIPTION
HA-382 VOLVO FRANCE

TITLE
PLC I/P CKT-2

| | |
|-------------------|--------|
| PROJECT CODE :- | HA-382 |
| DRAWING NUMBER :- | |
| Page | 49 |
| Pages | 147 |

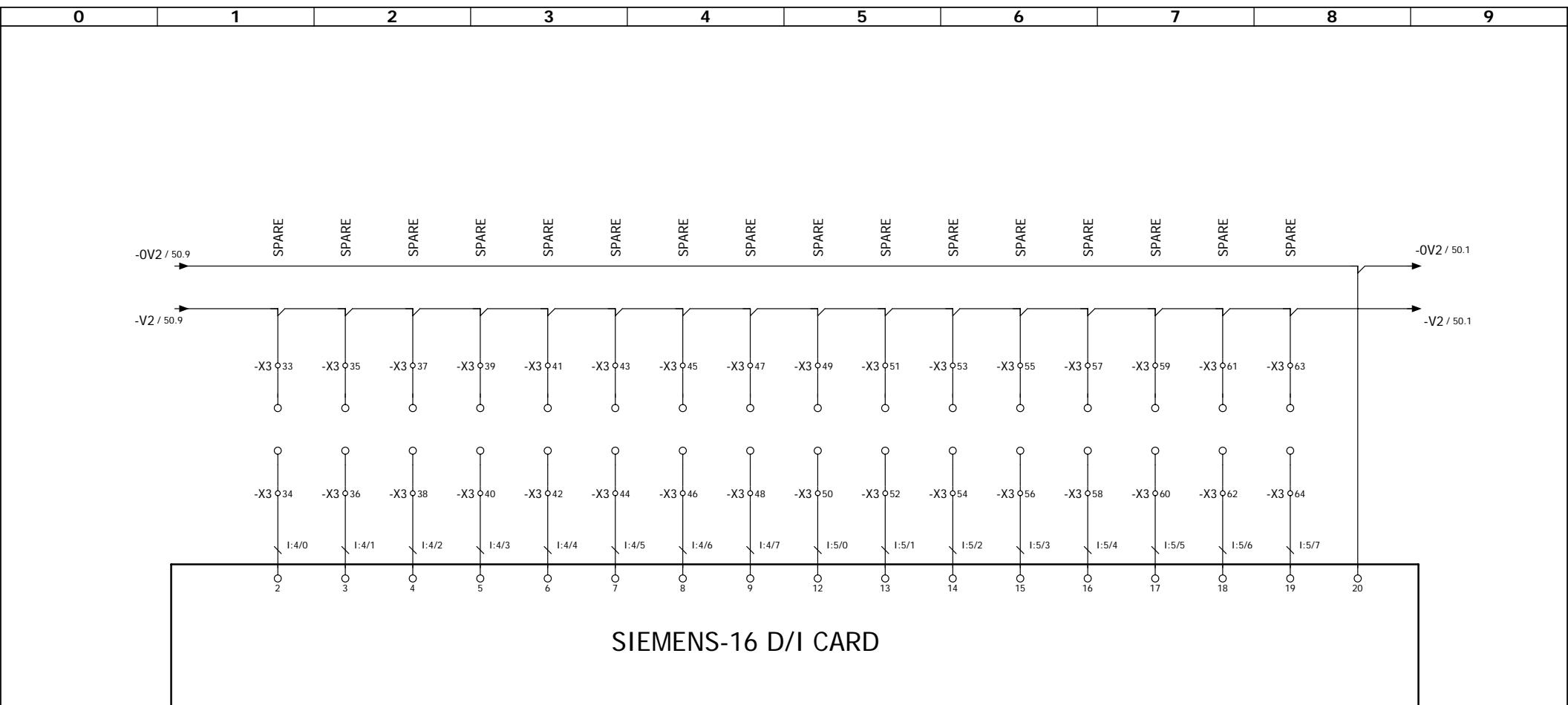

DOCUMENT ID : CY/DD/R/07
 REV : 00

CYBERNETIK TECHNOLOGIES
 PVT.LTD, PUNE

| | | |
|----------|------|--------|
| Drawn | Date | Name |
| CHECKED | | SHITAL |
| APPROVED | | |

PROJECT DESCRIPTION
 HA-382 VOLVO FRANCE

TITLE
 PLC I/P CKT-3

PROJECT CODE:- **HA-382**
 DRAWING NUMBER :-

0

1

2

3

4

5

6

7

8

9

SIEMENS-32 D/O CARD

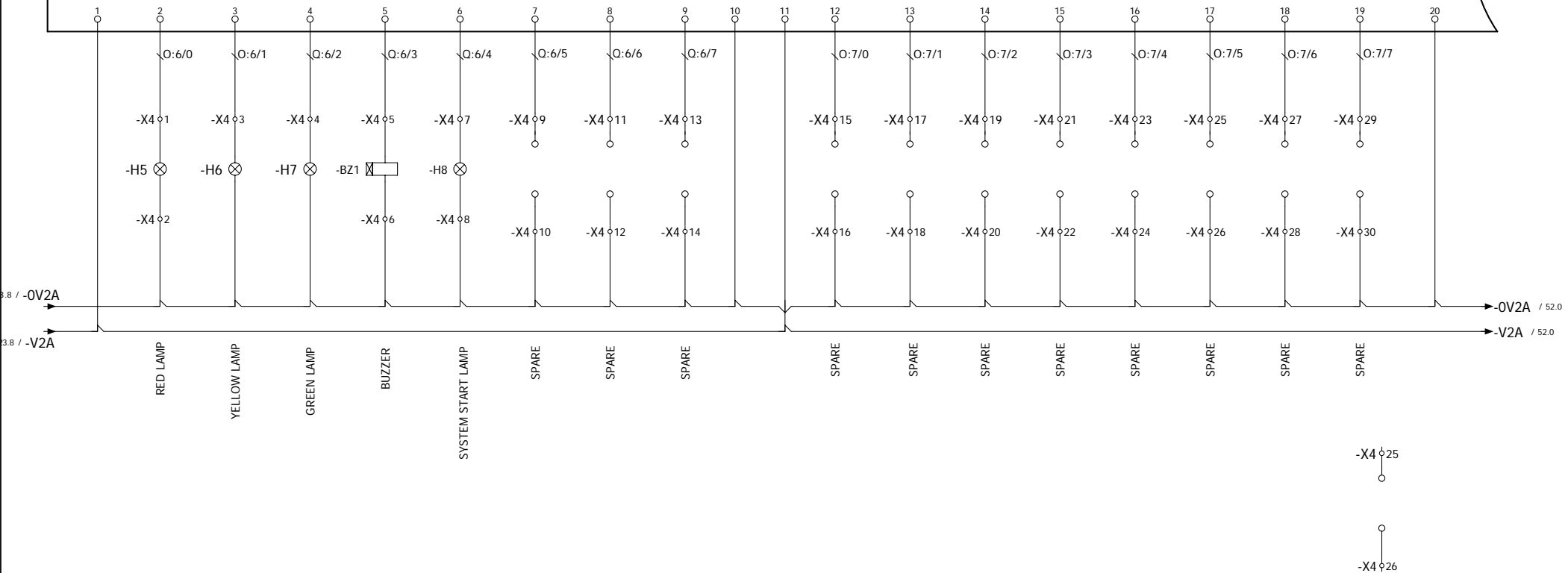

DOCUMENT ID : CY/DD/R/07
REV : 00

CYBERNETIK TECHNOLOGIES PVT.LTD, PUNE

| | | |
|----------|------|--------|
| Drawn | Date | Name |
| Checked | | SHITAL |
| Approved | | |

PROJECT DESCRIPTION
HA-382 VOLVO FRANCE

TITLE
PLC O/P CKT-1

| | |
|--------------------------|---------------|
| PROJECT CODE:- | HA-382 |
| DRAWING NUMBER :- | |
| Page | 51 |
| Pages | 147 |

0

1

2

3

4

5

6

7

8

9

SIEMENS-32 D/O CARD

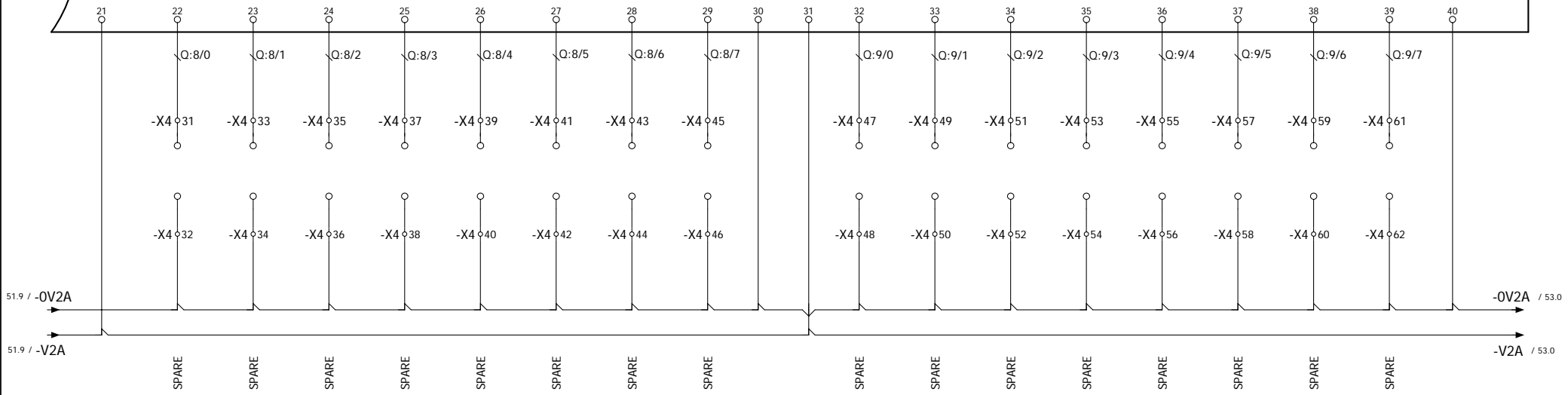

DOCUMENT ID : CY/DD/R/07
REV : 00



CYBERNETIK TECHNOLOGIES
PVT.LTD, PUNE

| | |
|----------|--------|
| DATE | NAME |
| | SHITAL |
| CHECKED | |
| APPROVED | |

PROJECT DESCRIPTION
HA-382 VOLVO FRANCE

TITLE
PLC O/P CKT-2

| | |
|-------------------|---------------|
| PROJECT CODE :- | HA-382 |
| DRAWING NUMBER :- | |
| Page | 52 |
| Pages | 147 |

SIEMENS-8 D/O CARD

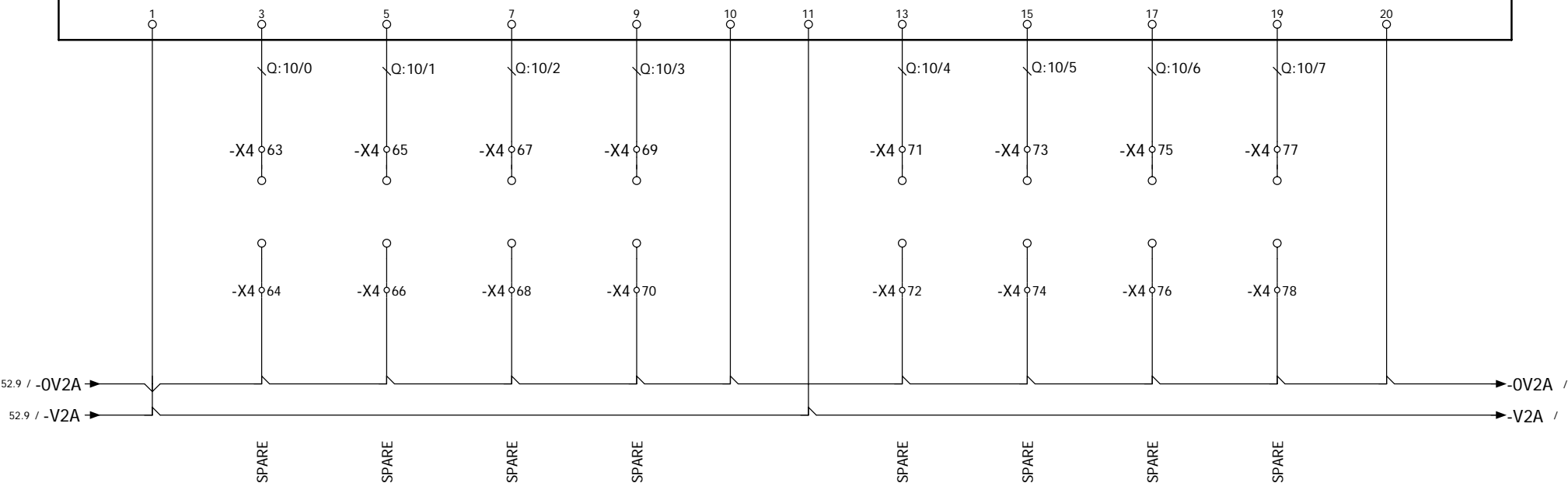

DOCUMENT ID : CY/DD/R/07
REV : 00

 CYBERNETIK TECHNOLOGIES
PVT.LTD, PUNE

| | | |
|----------|------|--------|
| Drawn | Date | Name |
| CHECKED | | SHITAL |
| APPROVED | | |

PROJECT DESCRIPTION
HA-382 VOLVO FRANCE

TITLE
PLC O/P CKT-3

PROJECT CODE:- **HA-382**
DRAWING NUMBER :-
Page 53
Pages 147

NODE-1 RB01
ROLLER BED DRIVE

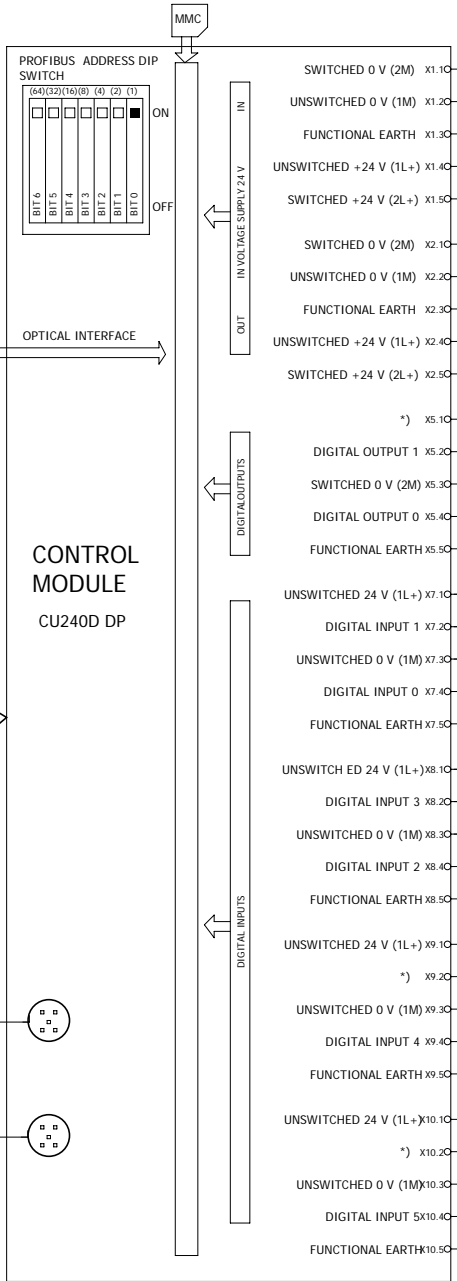
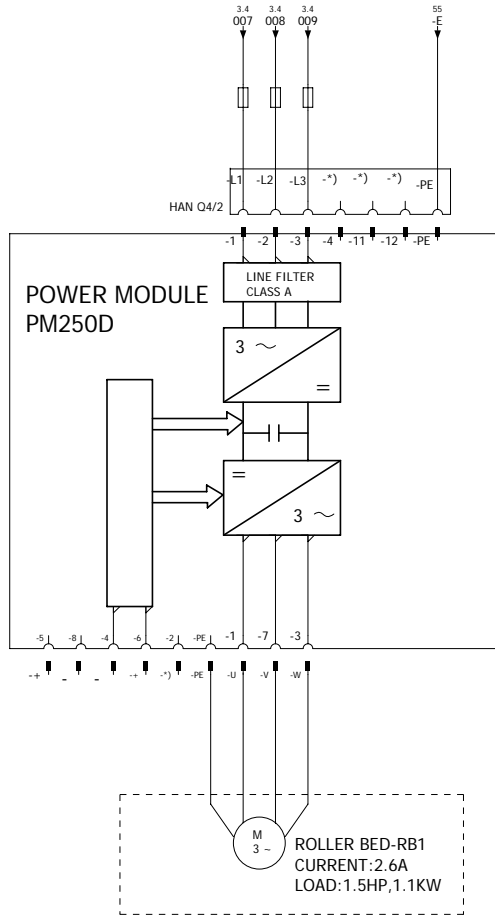

PROFIBUS DP interface IN FROM PLC PANEL

PROFIBUS DP interface OUT TO NODE-2

DOCUMENT ID : CY/DD/R/07
REV : 00



CYBERNETIK TECHNOLOGIES
PVT.LTD, PUNE

| | | |
|----------|------|--------|
| Drawn | Date | Name |
| Checked | | SHITAL |
| Approved | | |

| | |
|---------------------|--------|
| PROJECT DESCRIPTION | TITLE |
| HA-382 VOLVO FRANCE | NODE-1 |

| | |
|-------------------|--------|
| PROJECT CODE :- | HA-382 |
| DRAWING NUMBER :- | |

| | |
|-------|-----|
| Page | 54 |
| Pages | 147 |

**NODE-2 RB02
ROLLER BED DRIVE**

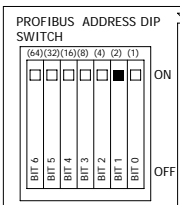
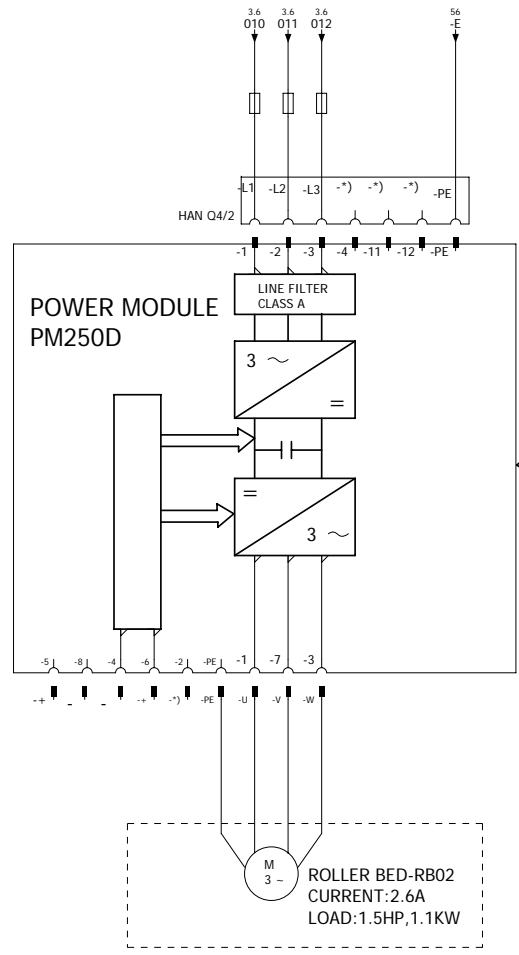

**CONTROL
MODULE
CU240D DP**

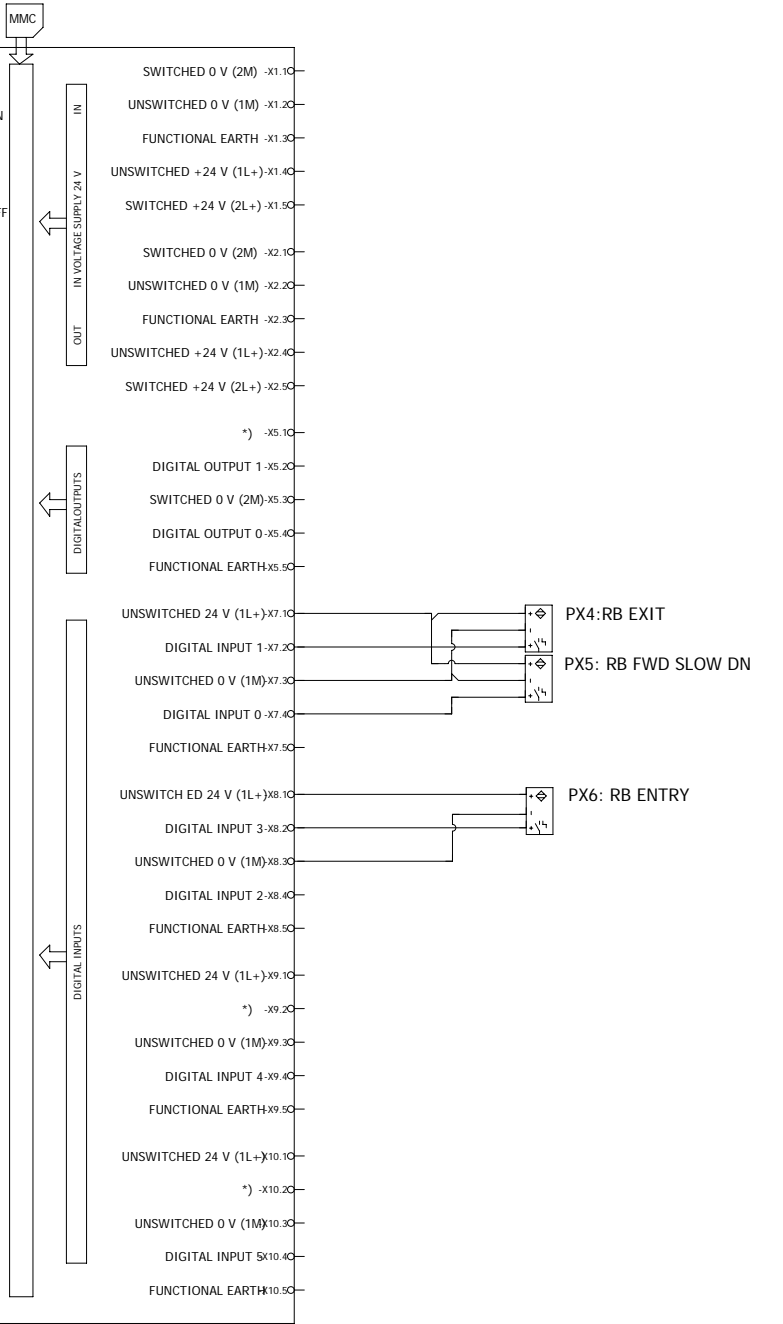

PM-IF INTERFACE

PROFIBUS DP interface IN / FROM NODE-1

PROFIBUS DP interface OUT / TO NODE-3

DOCUMENT ID : CY/DD/R/07
REV : 00

CYBERNETIK TECHNOLOGIES
PVT.LTD, PUNE

| | | |
|----------|------|--------|
| Drawn | Date | Name |
| CHECKED | | SHITAL |
| APPROVED | | |

PROJECT DESCRIPTION
HA-382 VOLVO FRANCE

TITLE
NODE-2

PROJECT CODE :- **HA-382**
DRAWING NUMBER :-
Page 55
Pages 147

NODE-3 RB03
ROLLER BED DRIVE

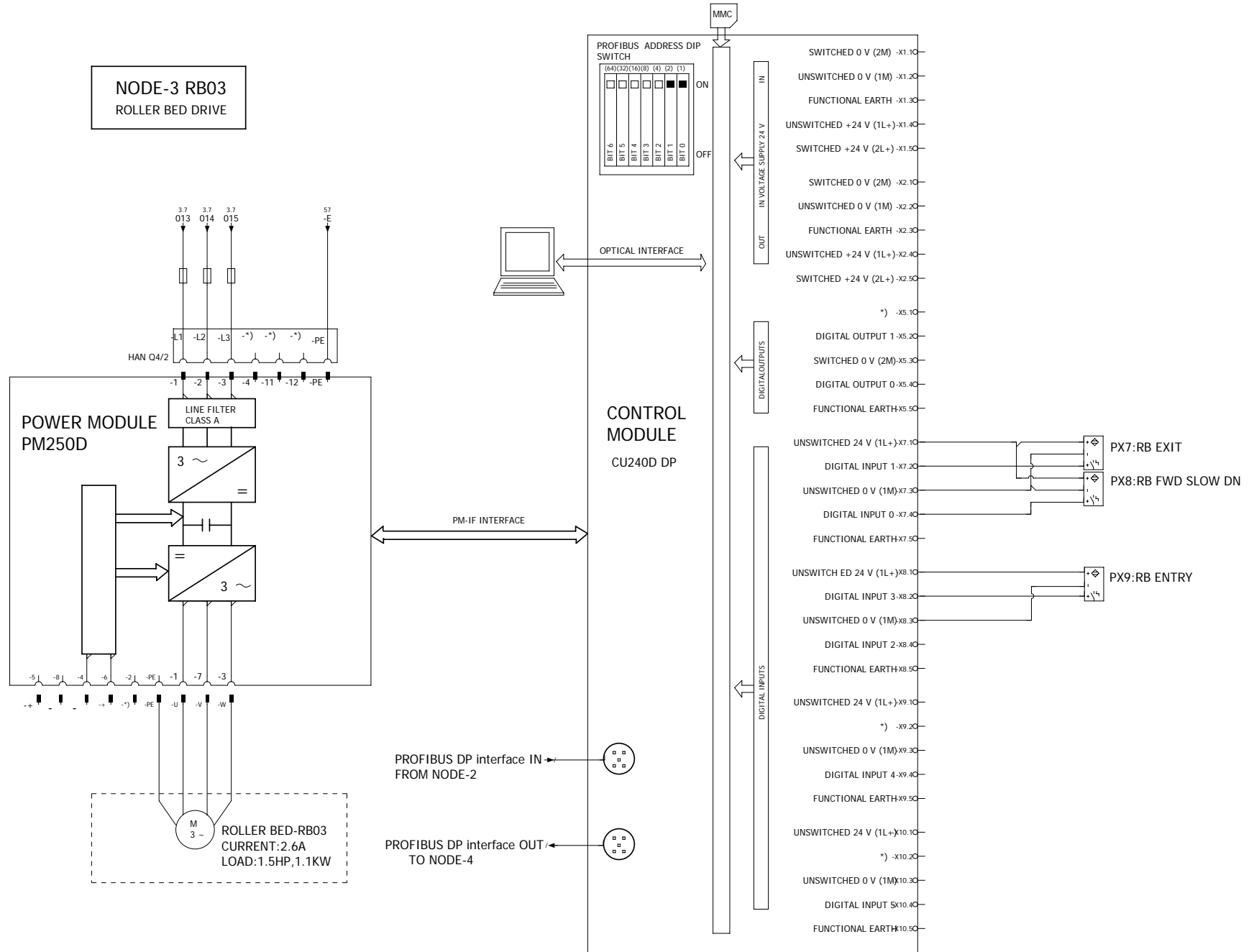

DOCUMENT ID : CY/DD/R/07

REV : 00

CYBERNETIK TECHNOLOGIES
PVT.LTD, PUNE

| | | |
|----------|------|--------|
| Drawn | Date | Name |
| Checked | | SHITAL |
| Approved | | |

PROJECT DESCRIPTION
HA-382 VOLVO FRANCE

TITLE
NODE-3

| | |
|-------------------|--------|
| PROJECT CODE :- | HA-382 |
| DRAWING NUMBER :- | |
| Page | 56 |
| Pages | 147 |

NODE-4 RB04
ROLLER BED DRIVE

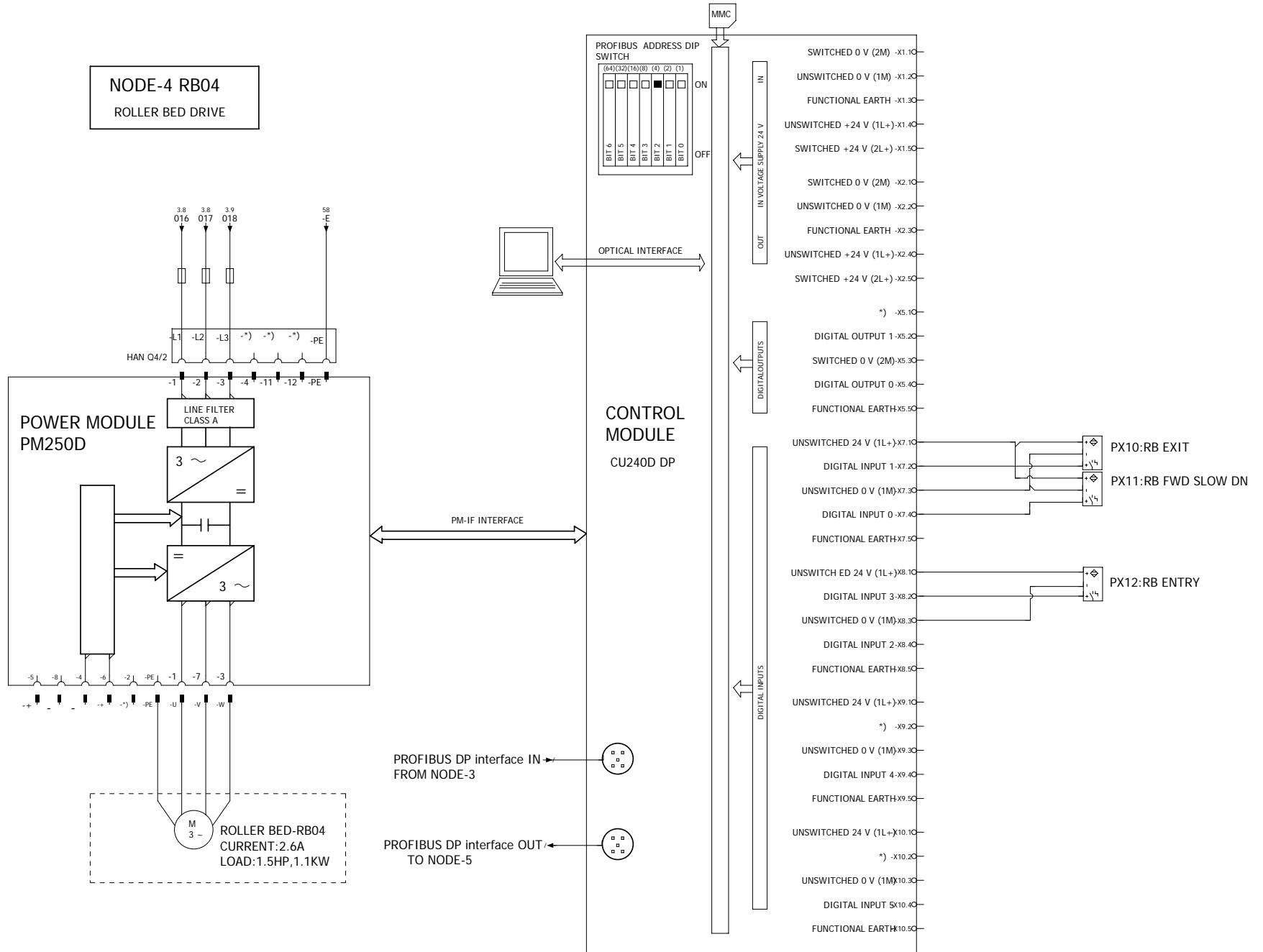

DOCUMENT ID : CY/DD/R/07
REV : 00

| | | |
|----------|------|--------|
| Drawn | Date | Name |
| Checked | | SHITAL |
| Approved | | |

NODE-5 RB05
ROLLER BED DRIVE

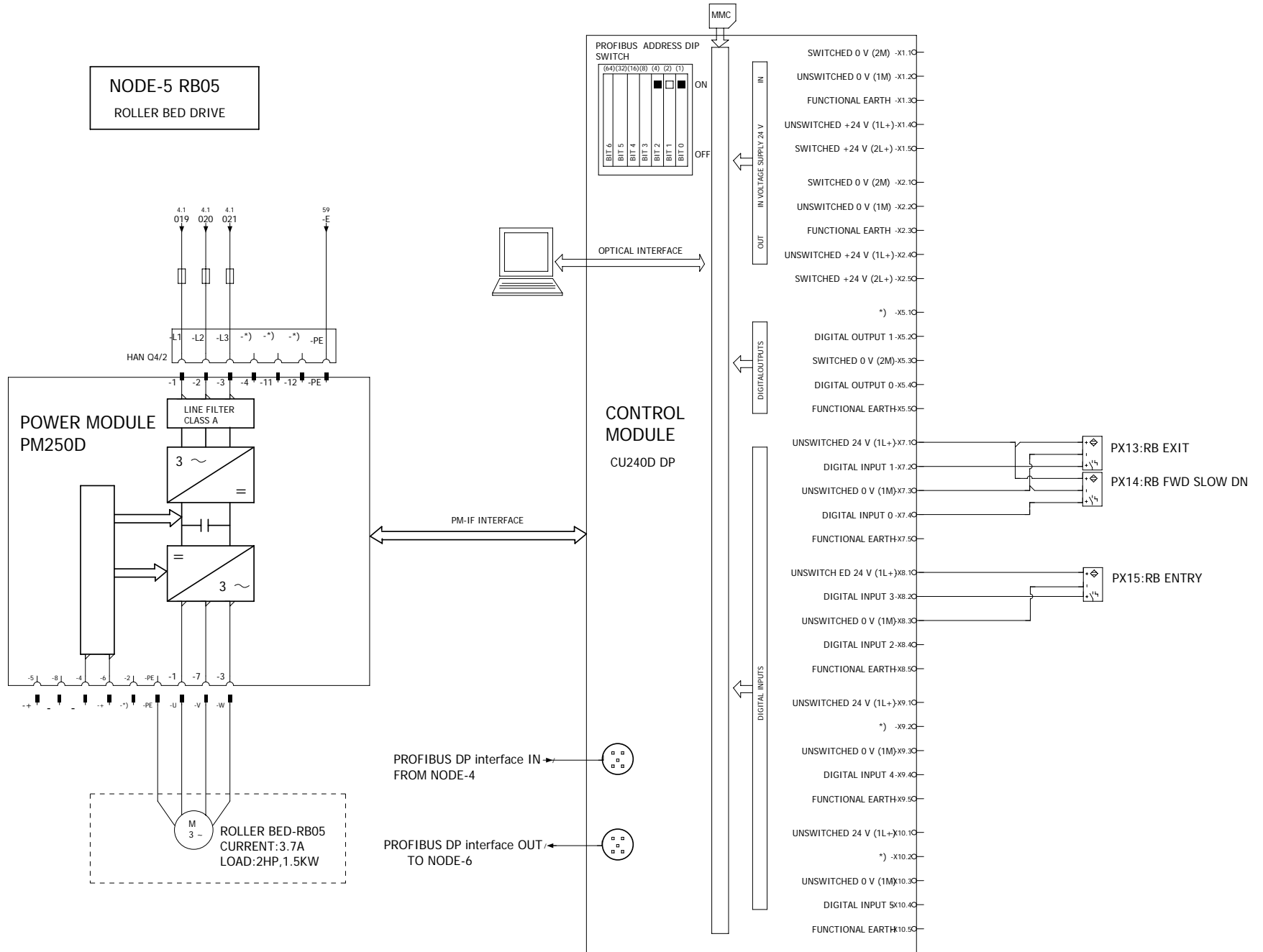

DOCUMENT ID : CY/DD/R/07
REV : 00

NODE-6 RBTS01-A
ROLLER BED DRIVE

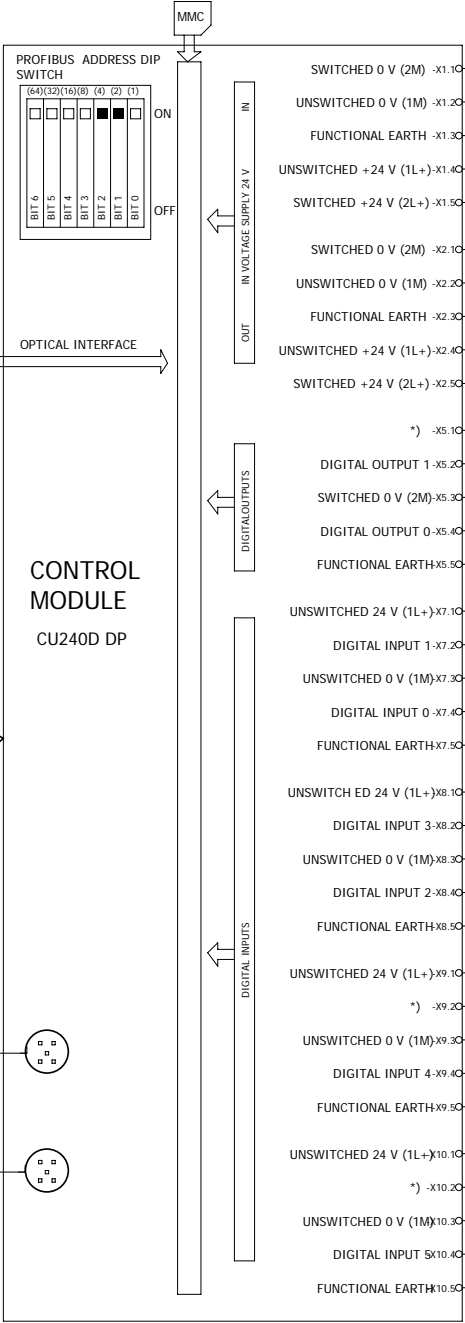
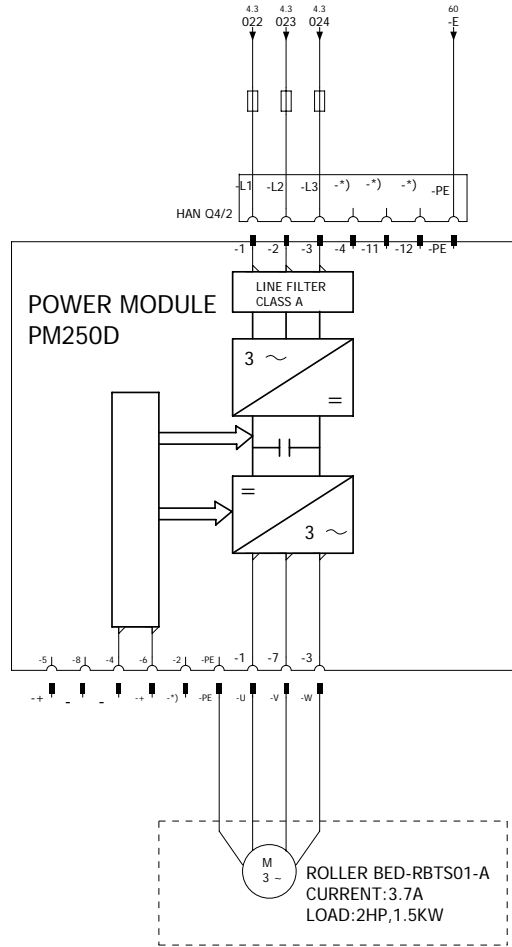

PROFIBUS DP interface IN FROM NODE-5

PROFIBUS DP interface OUT TO NODE-7

PX16:RB EXIT

PX17:RB FWD SLOW DN

PX18:RB ENTRY

DOCUMENT ID : CY/DD/R/07

REV : 00



CYBERNETIK TECHNOLOGIES
PVT.LTD, PUNE

| | Date | Name |
|----------|------|--------|
| DRAWN | | SHITAL |
| CHECKED | | |
| APPROVED | | |

PROJECT DESCRIPTION

HA-382 VOLVO FRANCE

TITLE

NODE-6

| | |
|-------------------|---------------|
| PROJECT CODE:- | HA-382 |
| DRAWING NUMBER :- | |
| Page | 59 |
| Pages | 147 |

NODE-7 RBTS01-B
TRANSFER CAR DRIVE

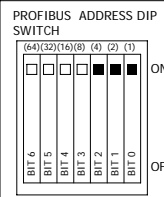
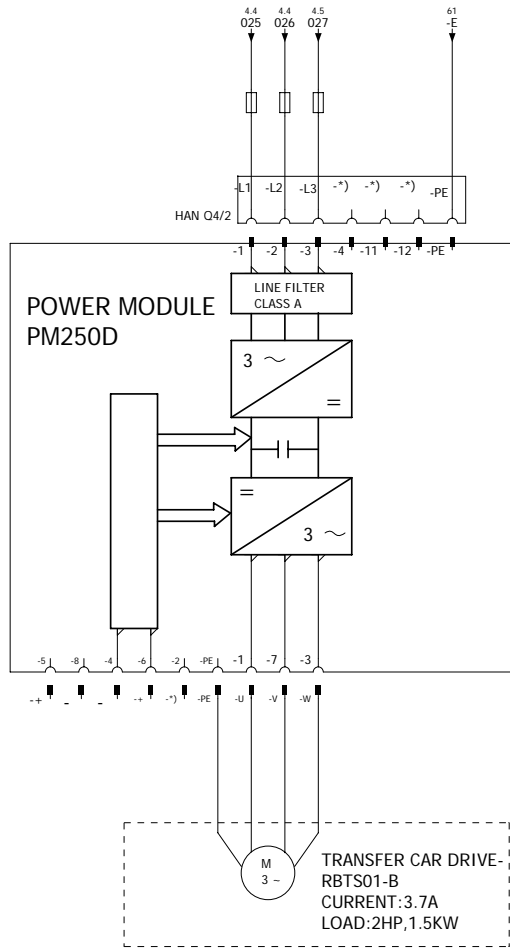

CONTROL MODULE
CU240D DP

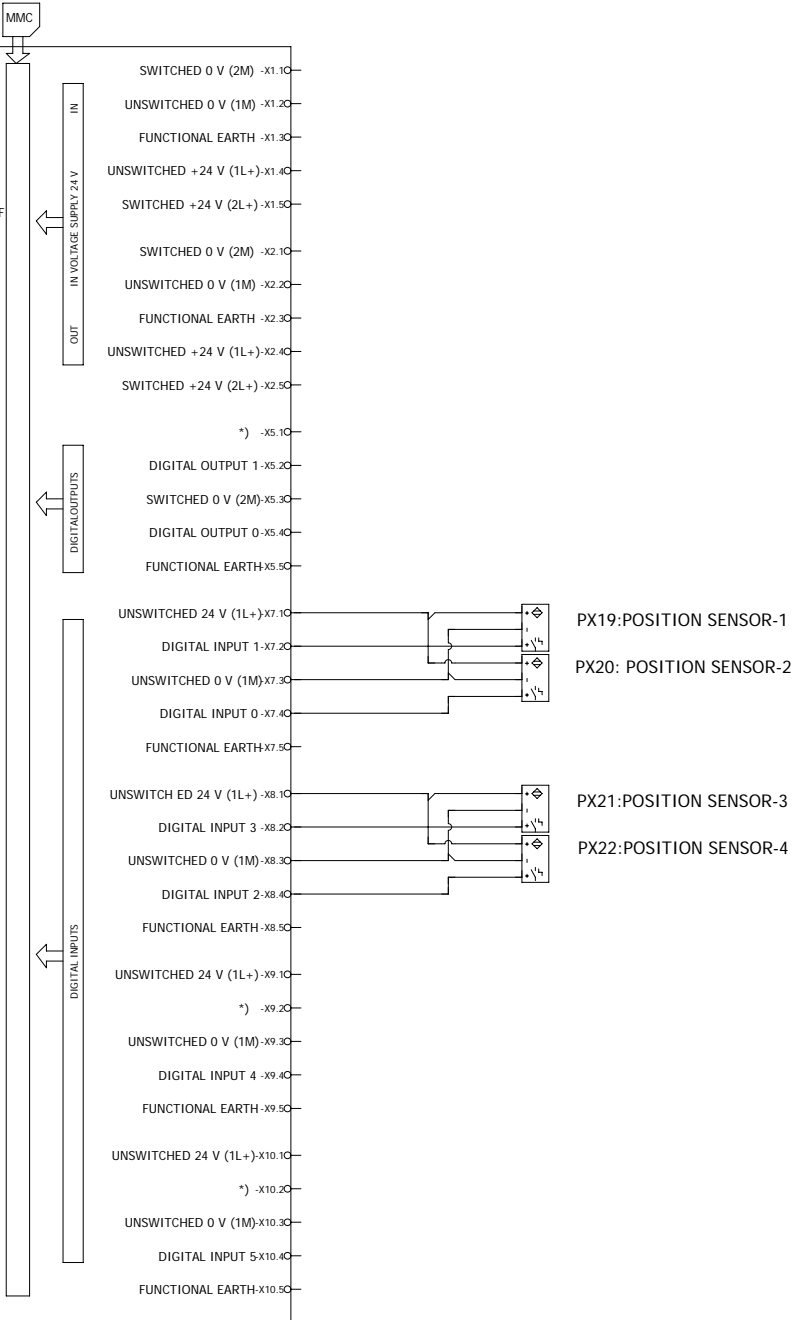
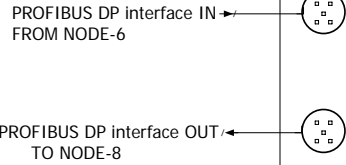

| | |
|----------|--------|
| DATE | NAME |
| | SHITAL |
| CHECKED | |
| APPROVED | |

| |
|---------------------|
| PROJECT DESCRIPTION |
| HA-382 VOLVO FRANCE |

| |
|--------|
| TITLE |
| NODE-7 |

| | |
|-------------------|---------------|
| PROJECT CODE :- | HA-382 |
| DRAWING NUMBER :- | |
| Page | 60 |
| Pages | 147 |

NODE-8 RB07
ROLLER BED DRIVE

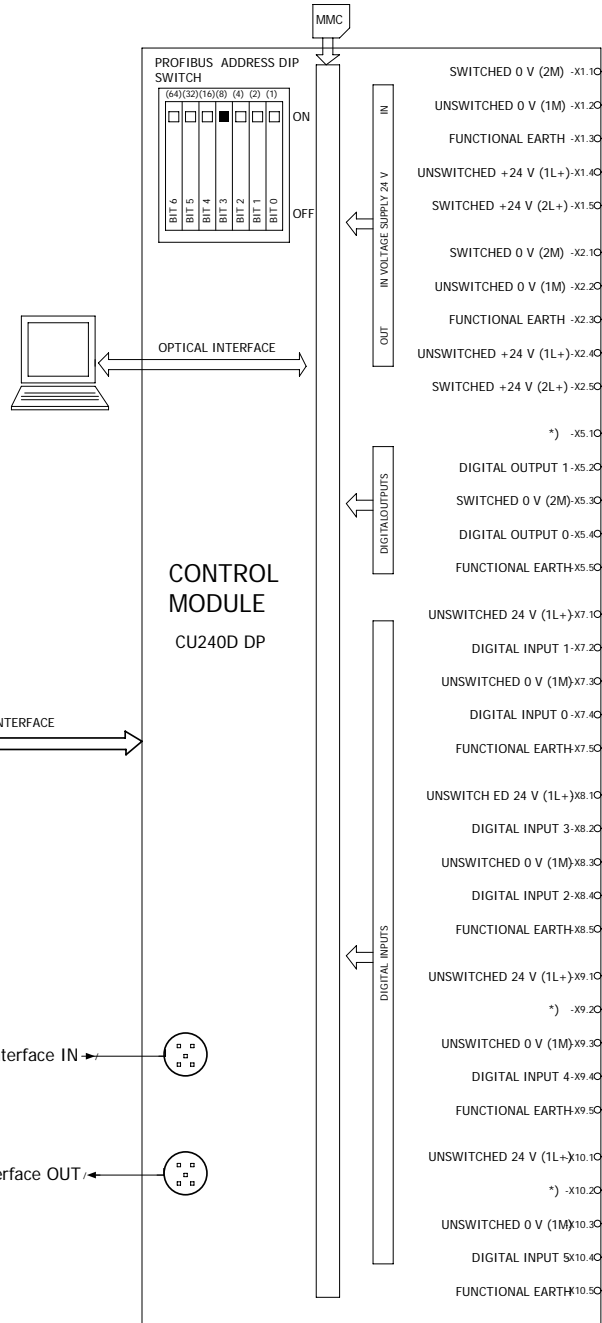
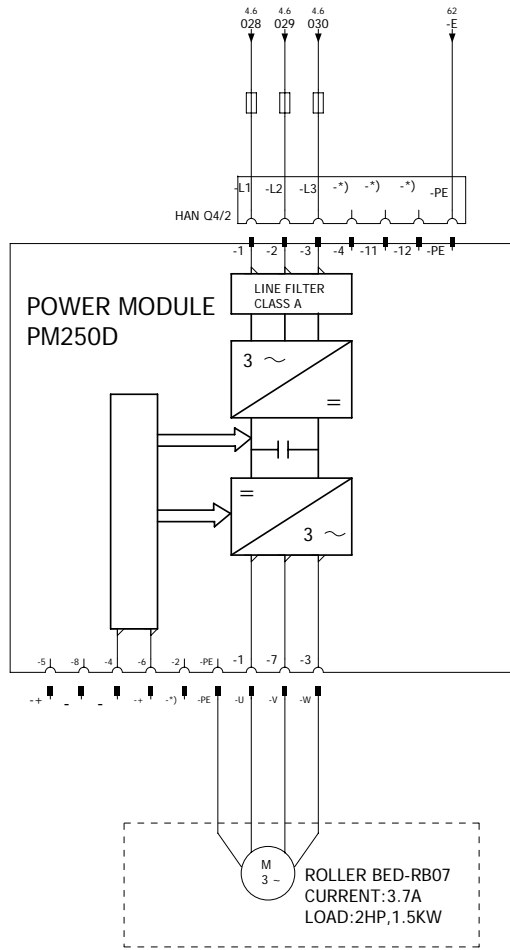

DOCUMENT ID : CY/DD/R/07
REV : 00

| | | |
|----------|------|--------|
| DRAWN | Date | Name |
| CHECKED | | SHITAL |
| APPROVED | | |

| | |
|---------------------|--------|
| PROJECT DESCRIPTION | TITLE |
| HA-382 VOLVO FRANCE | NODE-8 |

| | |
|-------------------|---------------|
| PROJECT CODE :- | HA-382 |
| DRAWING NUMBER :- | |

NODE-9 RB08
ROLLER BED DRIVE

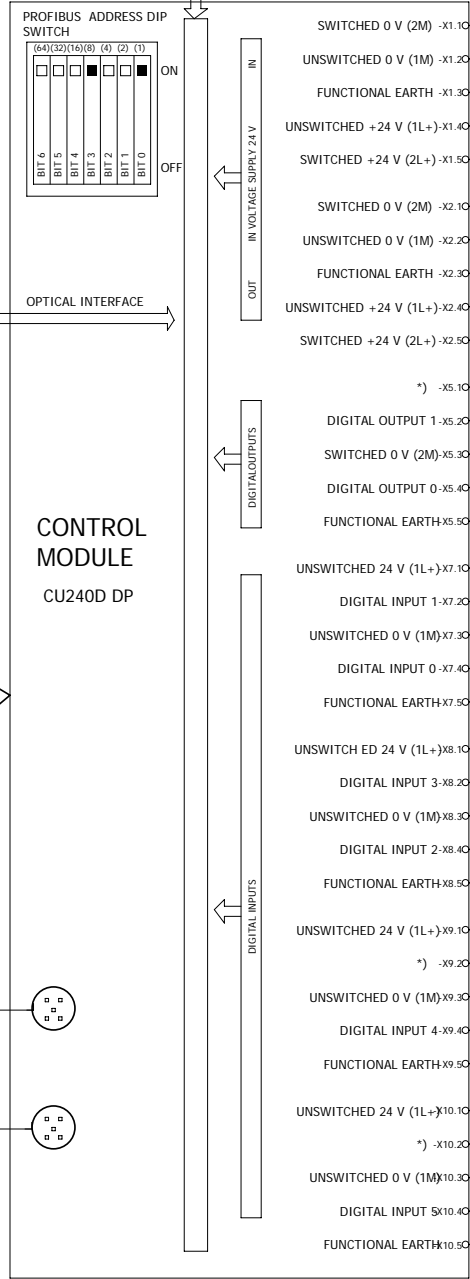
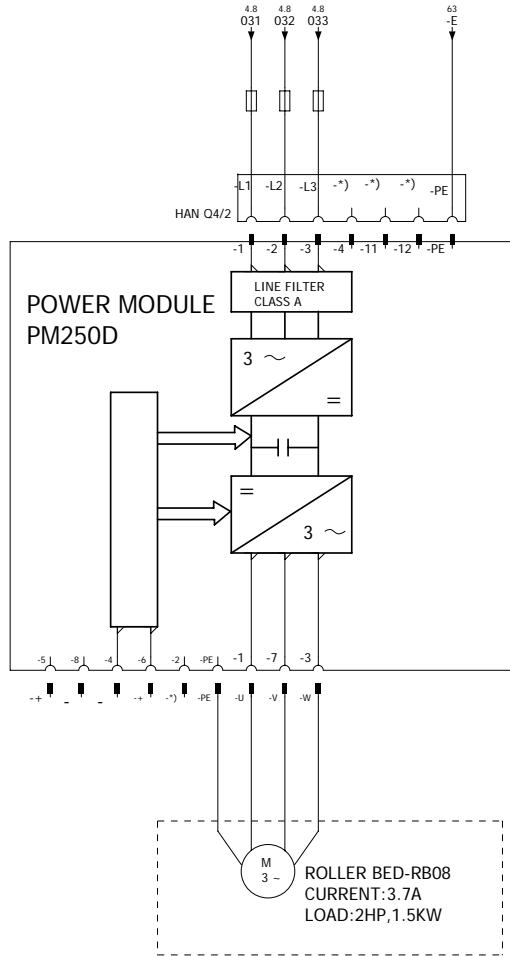

PROFIBUS DP interface IN FROM NODE-8

PROFIBUS DP interface OUT TO NODE-10

DOCUMENT ID : CY/DD/R/07
REV : 00

| | | |
|----------|------|--------|
| Drawn | Date | Name |
| Checked | | SHITAL |
| Approved | | |

| |
|---------------------|
| PROJECT DESCRIPTION |
| HA-382 VOLVO FRANCE |

| |
|--------|
| TITLE |
| NODE-9 |

| | |
|-------------------|---------------|
| PROJECT CODE :- | HA-382 |
| DRAWING NUMBER :- | |

NODE-10 RB09
ROLLER BED DRIVE

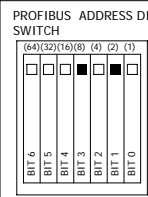
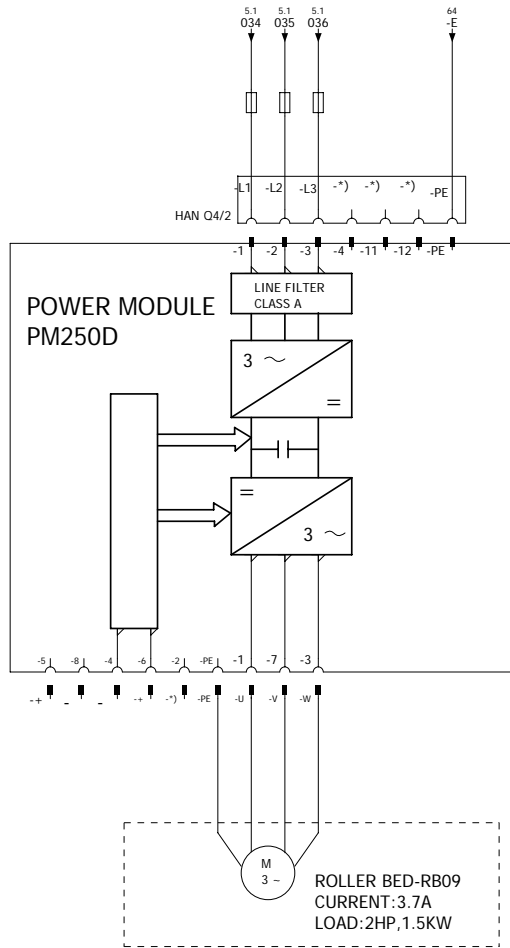

OPTICAL INTERFACE

CONTROL MODULE
CU240D DP

PM-IF INTERFACE

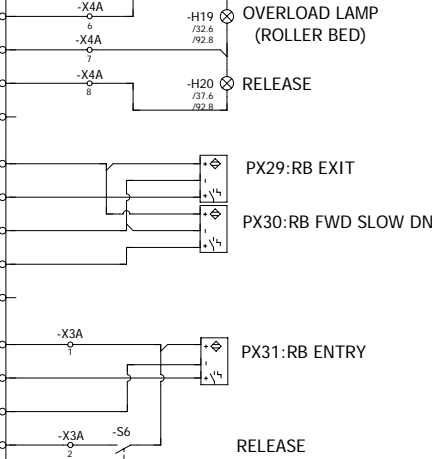
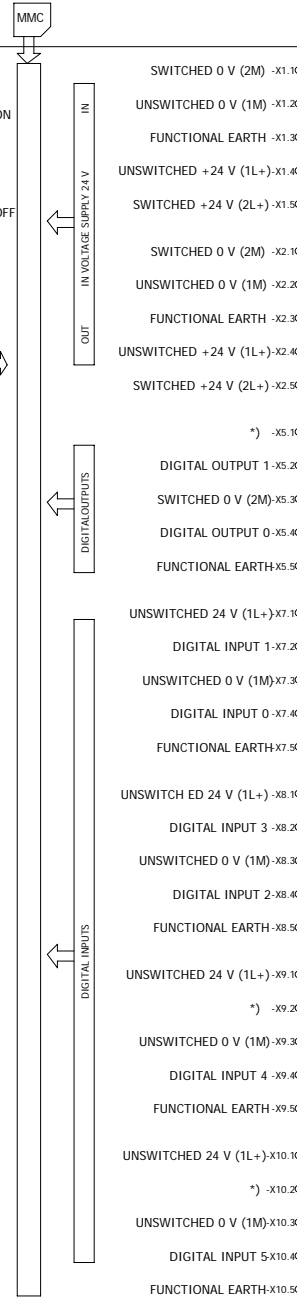
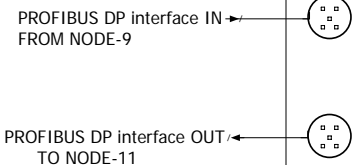

| | |
|----------|--------|
| DATE | NAME |
| | SHITAL |
| CHECKED | |
| APPROVED | |

| |
|---------------------|
| PROJECT DESCRIPTION |
| HA-382 VOLVO FRANCE |

| |
|---------|
| TITLE |
| NODE-10 |

| | |
|-------------------|--------|
| PROJECT CODE :- | HA-382 |
| DRAWING NUMBER :- | |

NODE-11 RB10
ROLLER BED DRIVE

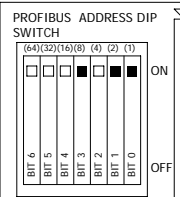
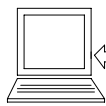
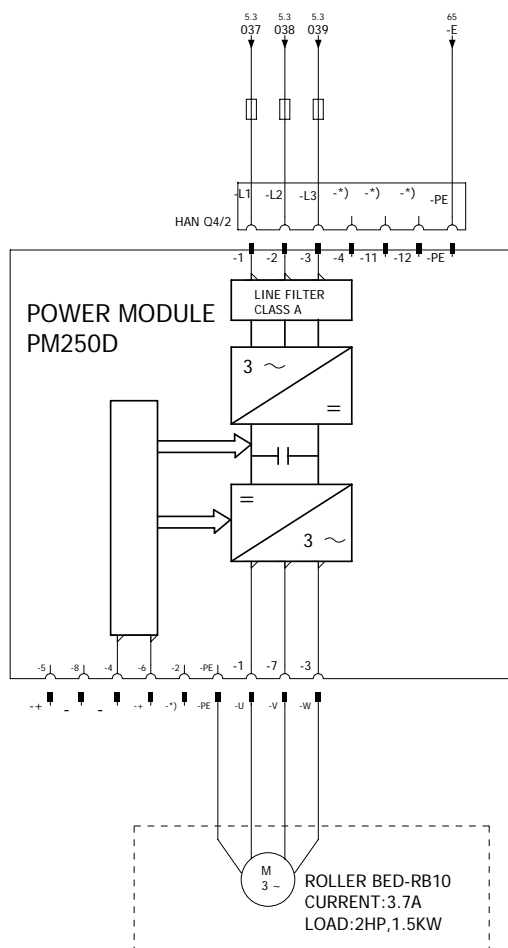

CONTROL MODULE
CU240D DP

PM-IF INTERFACE

PROFIBUS DP interface IN FROM NODE-10

PROFIBUS DP interface OUT TO NODE-12

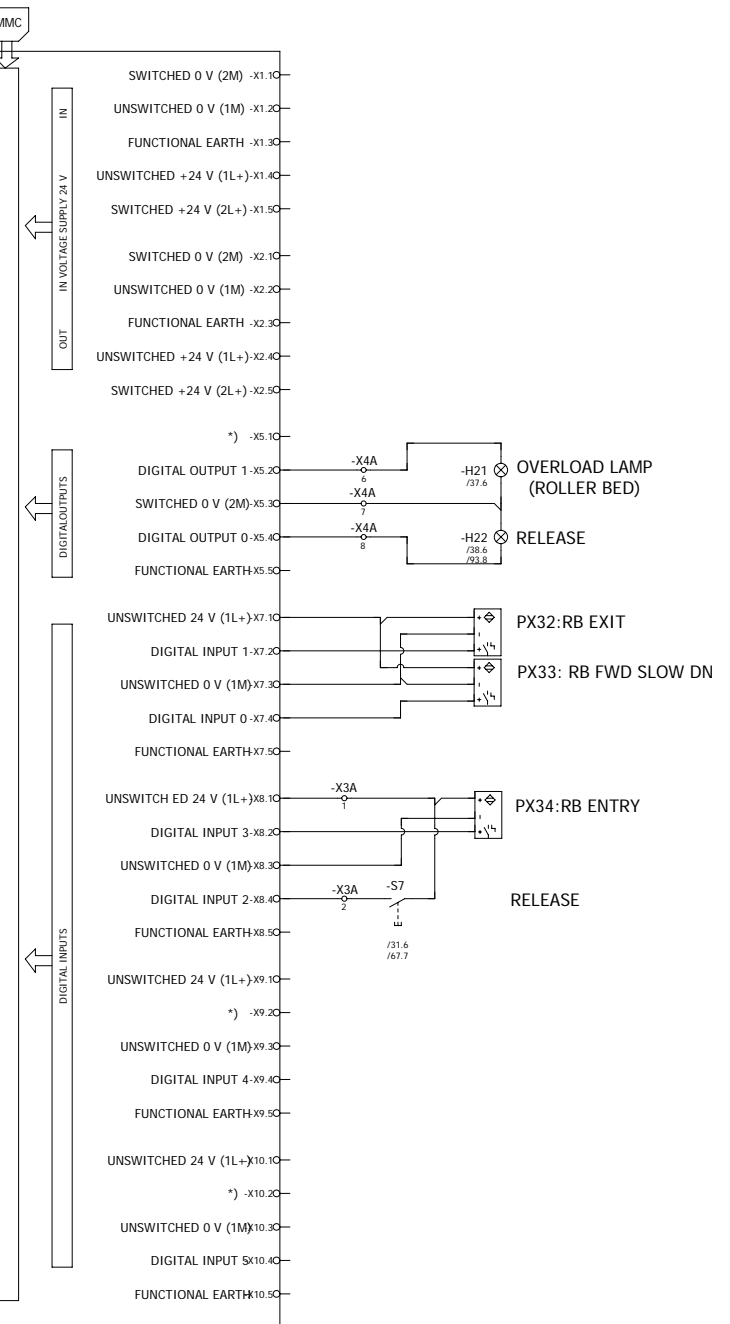

DOCUMENT ID : CY/DD/R/07
REV : 00

| | |
|----------|--------|
| DATE | NAME |
| | SHITAL |
| CHECKED | |
| APPROVED | |

| |
|---------------------|
| PROJECT DESCRIPTION |
| HA-382 VOLVO FRANCE |

| |
|---------|
| TITLE |
| NODE-11 |

| | |
|-------------------|---------------|
| PROJECT CODE :- | HA-382 |
| DRAWING NUMBER :- | |
| Page | 64 |
| Pages | 147 |

NODE-12 RBSL01-A
ROLLER BED DRIVE

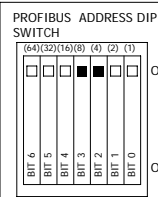
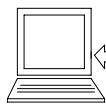
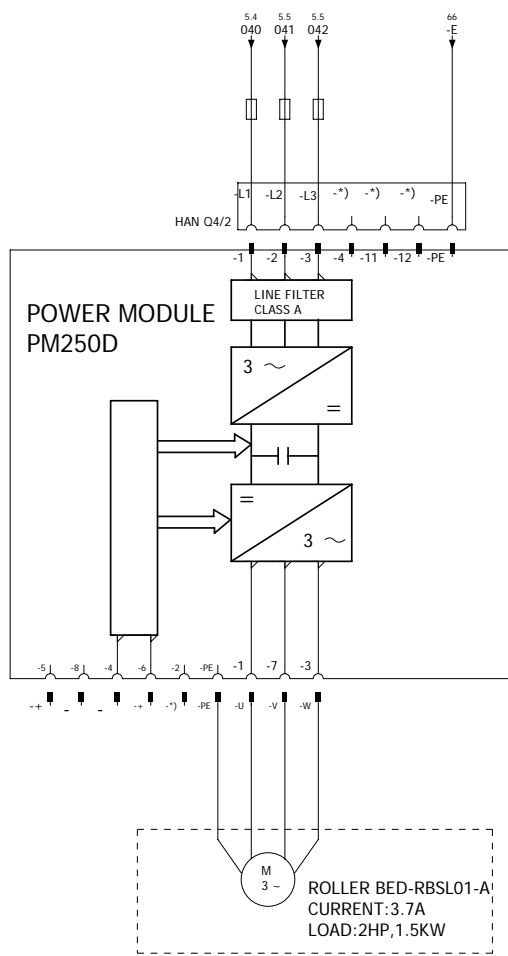

OPTICAL INTERFACE

CONTROL MODULE
CU240D DP

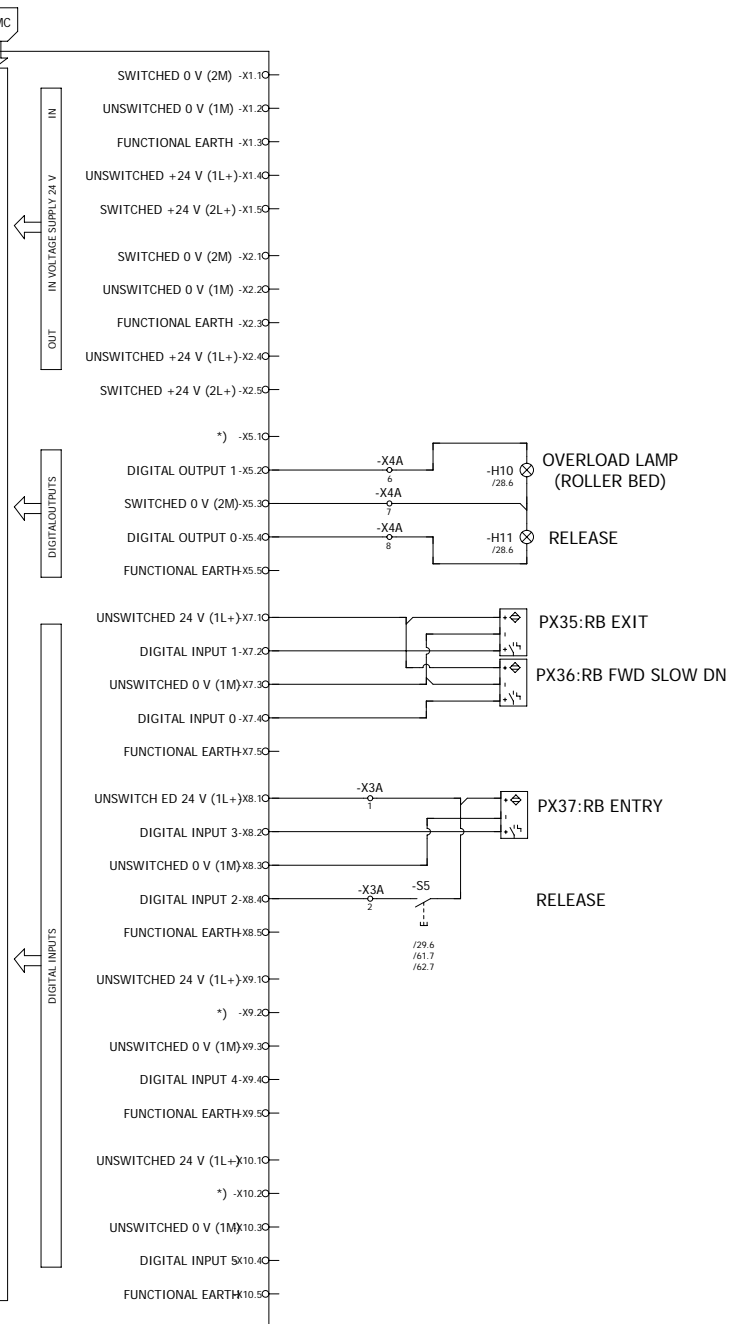

PM-IF INTERFACE

PROFIBUS DP interface IN FROM NODE-11

PROFIBUS DP interface OUT TO NODE-13

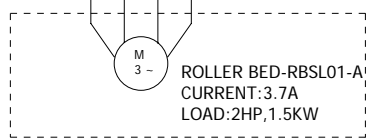

DOCUMENT ID : CY/DD/R/07
REV : 00

| | |
|----------|--------|
| DATE | NAME |
| CHECKED | SHITAL |
| APPROVED | |

| | |
|---------------------|---------|
| PROJECT DESCRIPTION | TITLE |
| HA-382 VOLVO FRANCE | NODE-12 |

| | |
|-------------------|--------|
| PROJECT CODE :- | HA-382 |
| DRAWING NUMBER :- | |

NODE-13 RBSL01B
LIFT MOTOR DRIVE

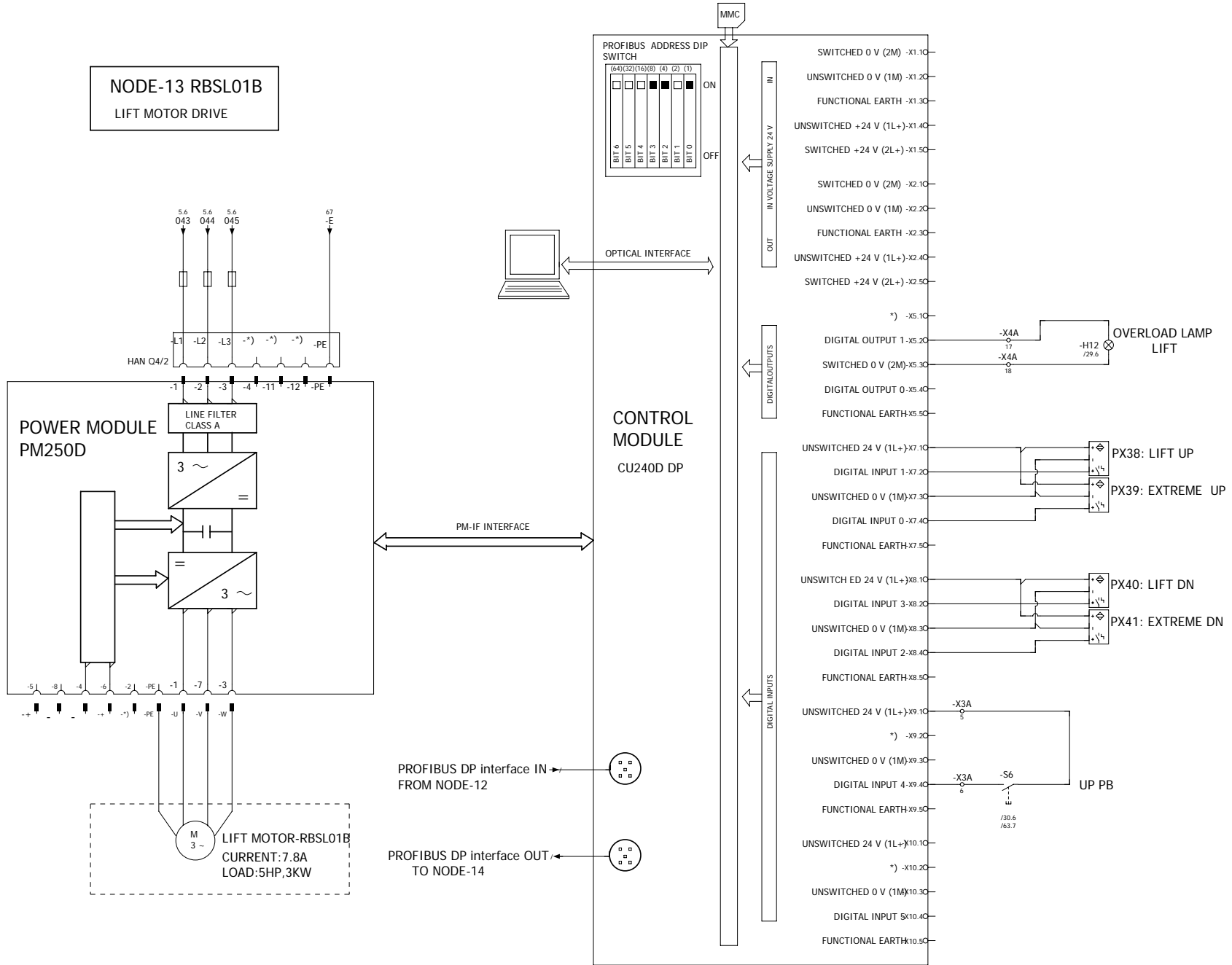

DOCUMENT ID : CY/DD/R/07
REV : 00

| | | |
|----------|------|--------|
| Drawn | Date | Name |
| Checked | | SHITAL |
| Approved | | |

| | |
|---------------------|---------|
| PROJECT DESCRIPTION | TITLE |
| HA-382 VOLVO FRANCE | NODE-13 |

| | |
|-------------------|--------|
| PROJECT CODE :- | HA-382 |
| DRAWING NUMBER :- | |

NODE-14 RBSL02-A
ROLLER BED DRIVE

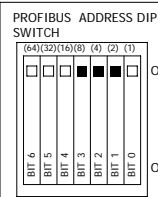
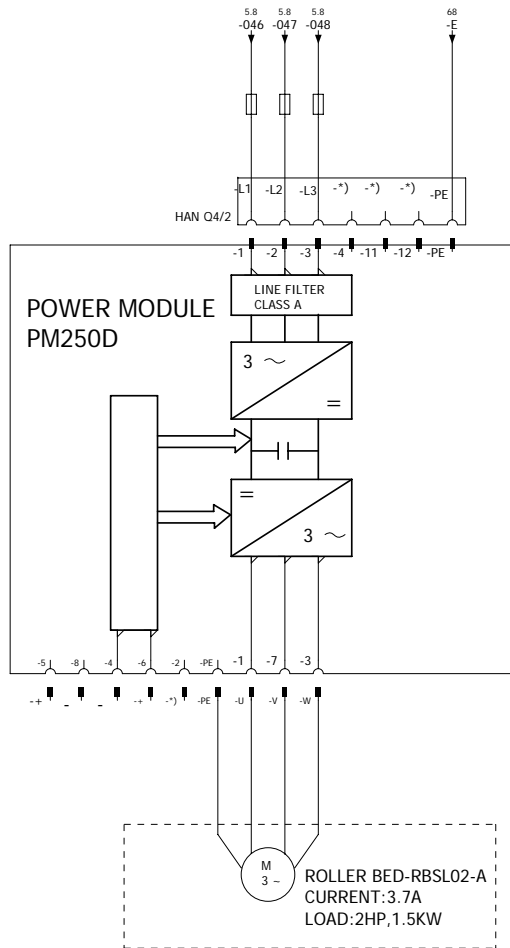

CONTROL MODULE
CU240D DP

PM-IF INTERFACE

PROFIBUS DP interface IN FROM NODE-13
PROFIBUS DP interface OUT TO NODE-15

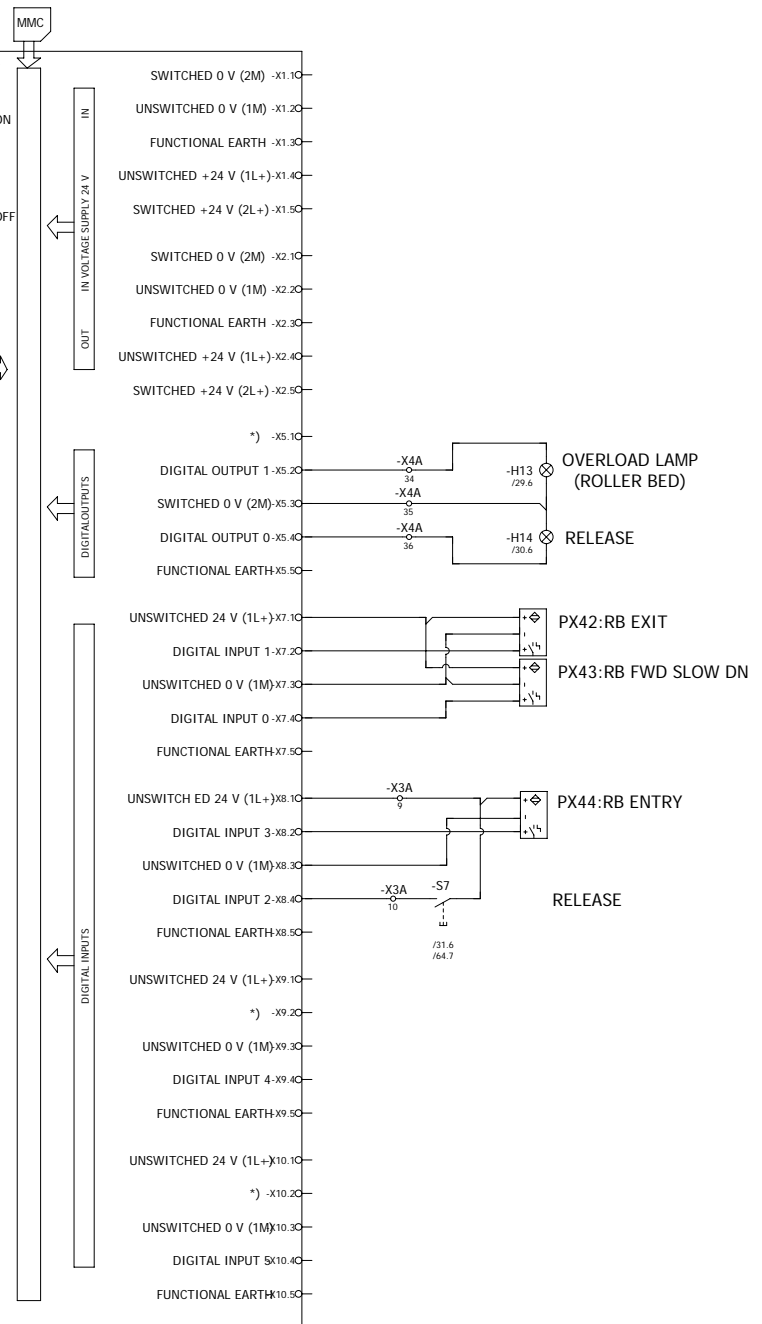

DOCUMENT ID : CY/DD/R/07

REV : 00

CYBERNETIK TECHNOLOGIES PVT.LTD, PUNE

| | | |
|----------|------|--------|
| Drawn | Date | Name |
| Checked | | SHITAL |
| Approved | | |

PROJECT DESCRIPTION
HA-382 VOLVO FRANCE

TITLE
NODE-14

| | |
|-------------------|--------|
| PROJECT CODE :- | HA-382 |
| DRAWING NUMBER :- | |
| Page | 67 |
| Pages | 147 |

NODE-15 RBSL02-B
LIFT MOTOR

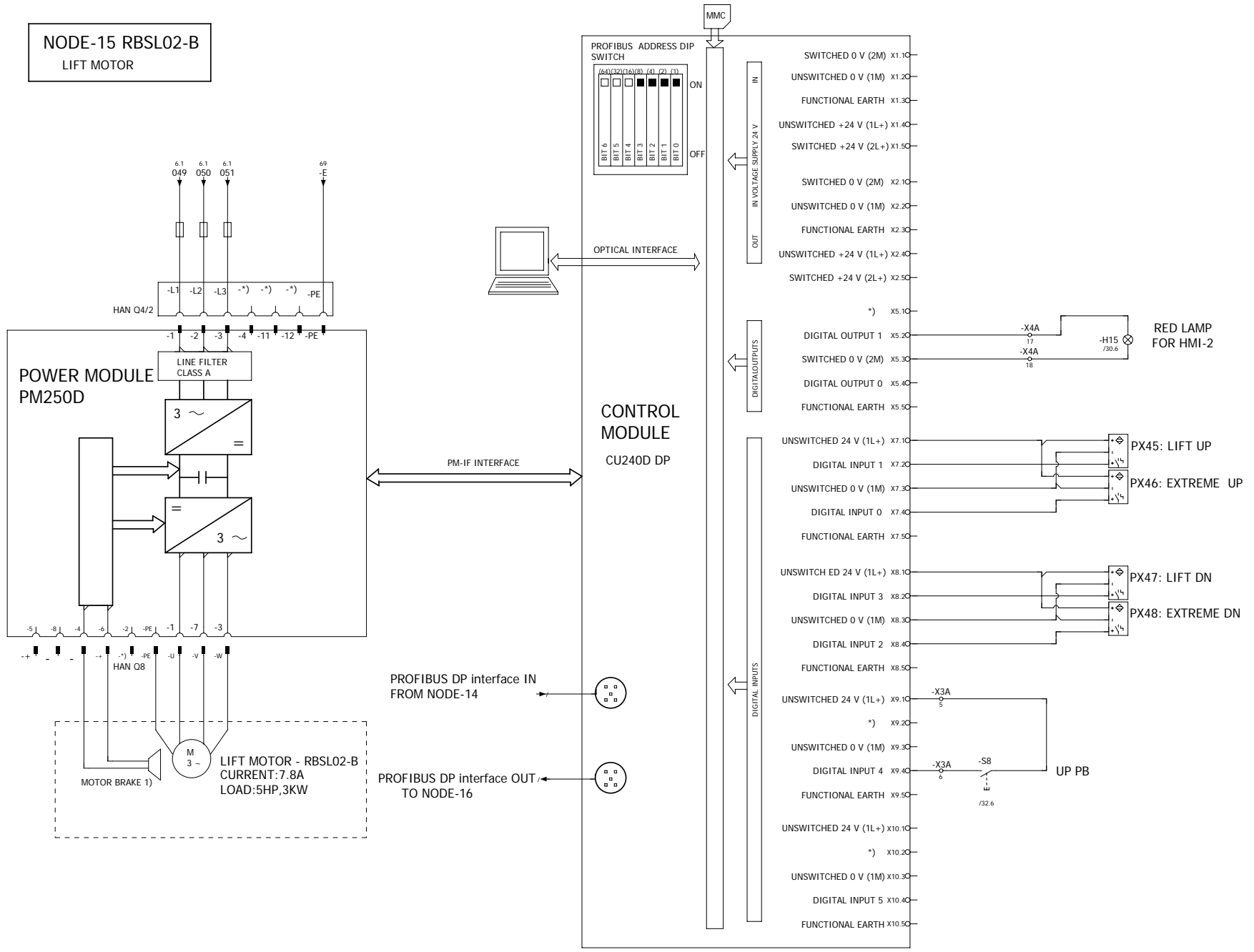

DOCUMENT ID : CY/DD/R/07
REV : 00

| | | |
|----------|------|--------|
| Drawn | Date | Name |
| Checked | | SHITAL |
| Approved | | |

NODE-16 RBTS02A
ROLLER BED

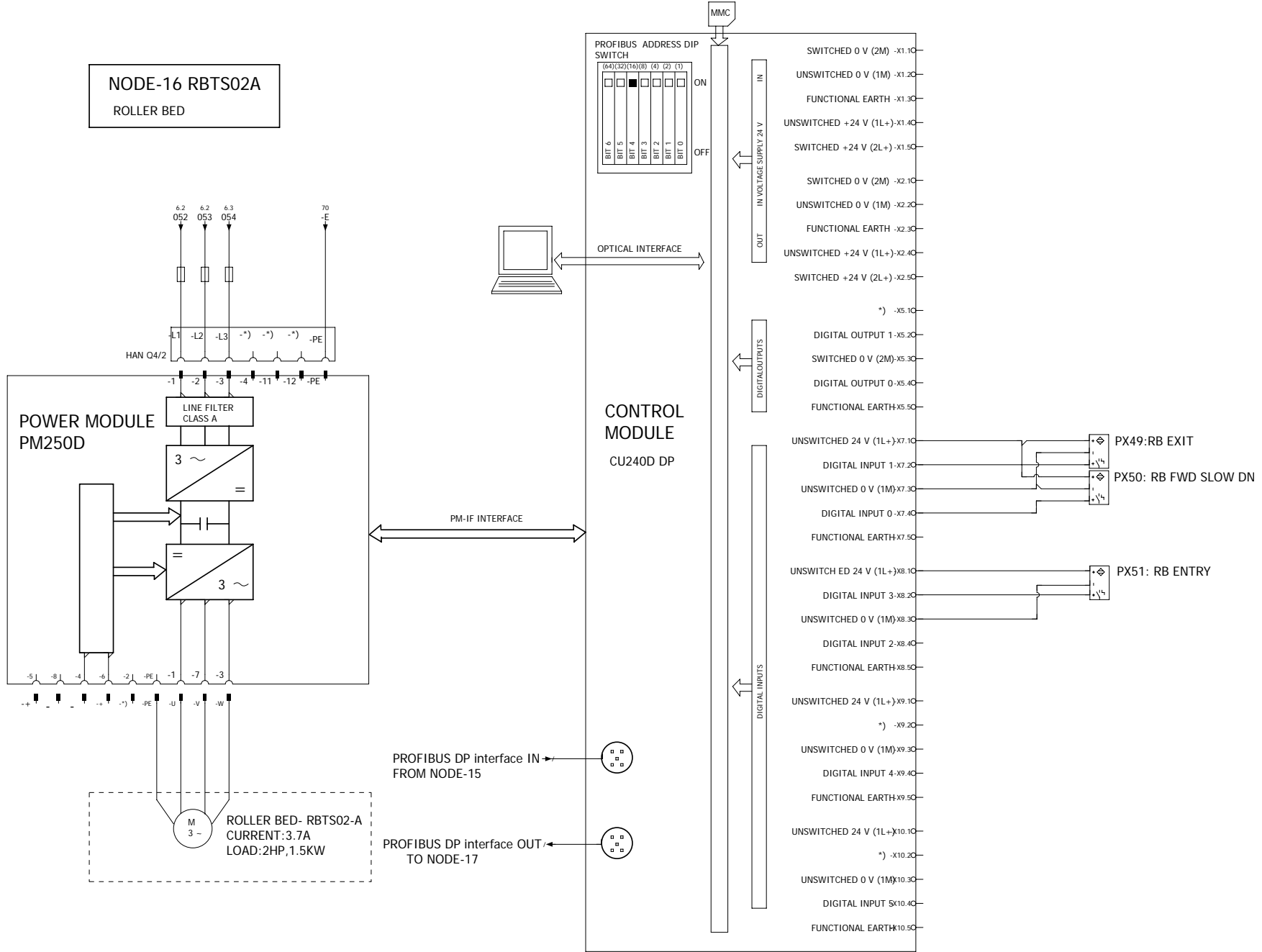

DOCUMENT ID : CY/DD/R/07
REV : 00

| | | |
|----------|------|--------|
| Drawn | Date | Name |
| Checked | | SHITAL |
| Approved | | |

| | |
|----------------------------|--------------|
| PROJECT DESCRIPTION | TITLE |
| HA-382 VOLVO FRANCE | NODE-16 |

| | |
|--------------------------|---------------|
| PROJECT CODE :- | HA-382 |
| DRAWING NUMBER :- | |

NODE-17 RBTS02-B
ROLLER BED DRIVE

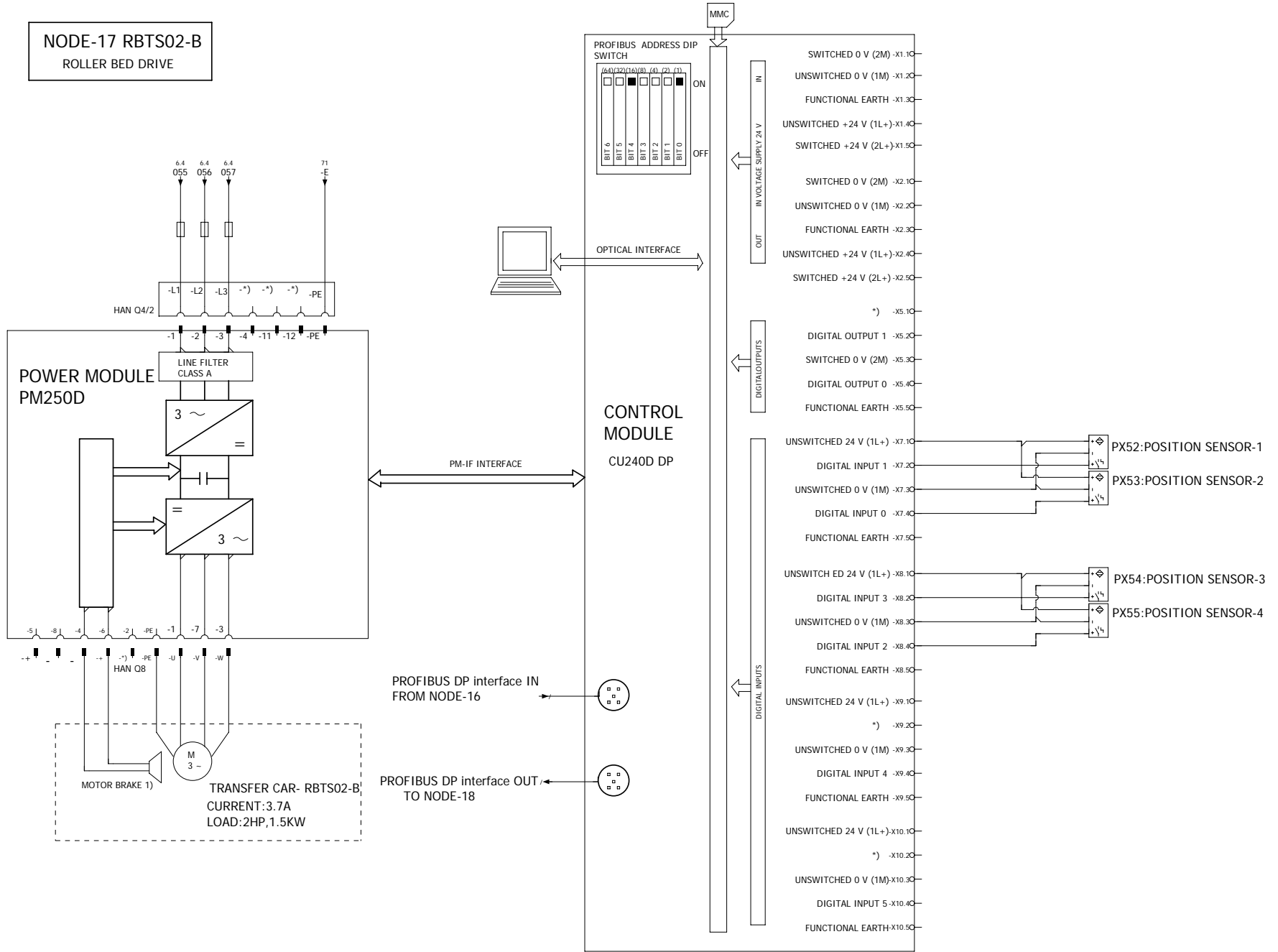

DOCUMENT ID : CY/DD/R/07
REV : 00

| | | |
|----------|------|--------|
| Drawn | Date | Name |
| Checked | | SHITAL |
| Approved | | |

NODE-18 RB06
ROLLER BED DRIVE

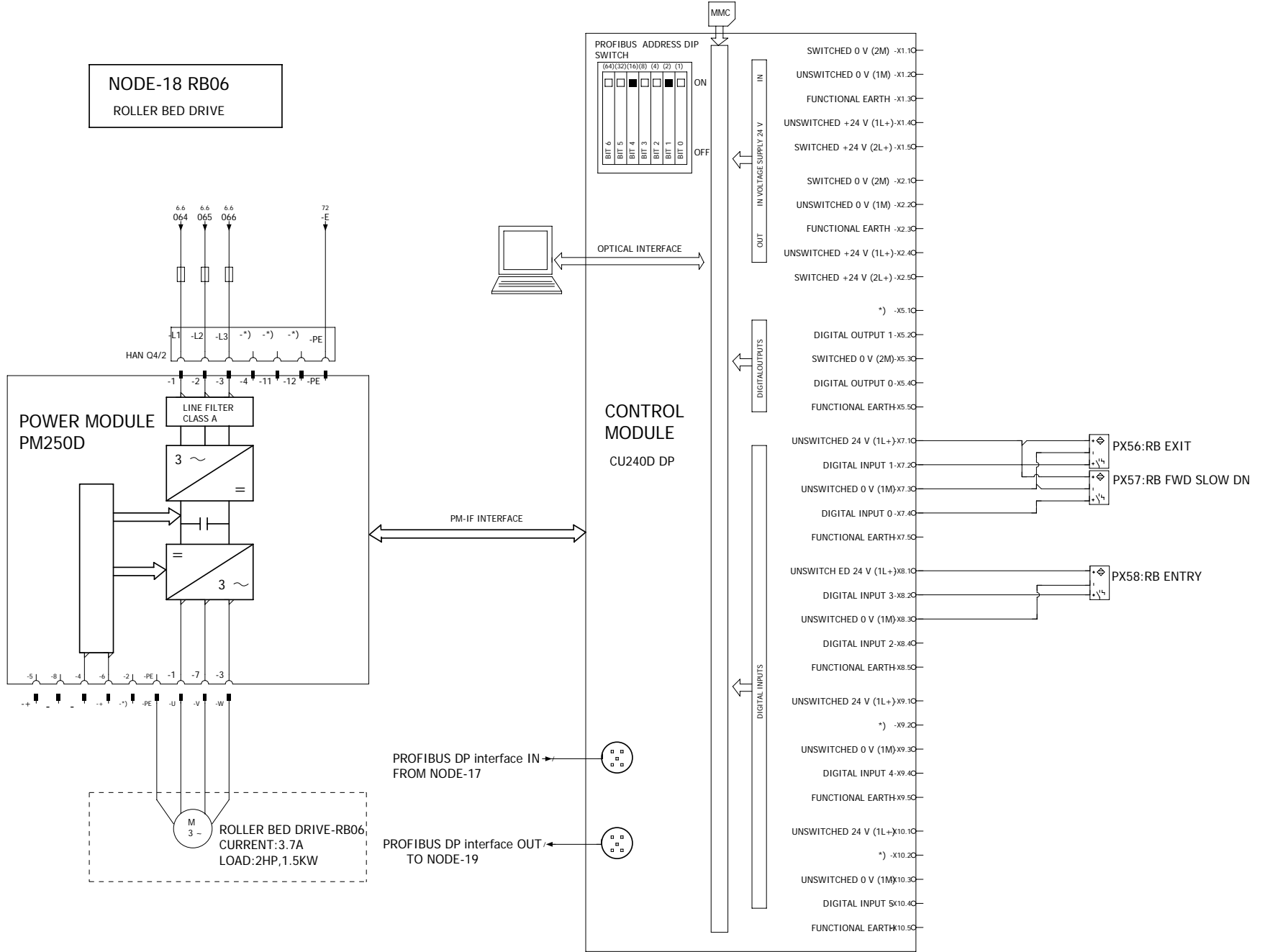

DOCUMENT ID : CY/DD/R/07
REV : 00

| Date | Name |
|------|--------|
| | SHITAL |
| | |
| | |

| PROJECT DESCRIPTION | TITLE |
|---------------------|---------|
| HA-382 VOLVO FRANCE | NODE-18 |

| PROJECT CODE :- | DRAWING NUMBER :- |
|-----------------|-------------------|
| HA-382 | |

NODE-19 PC01
PAINT CONV. DRIVE

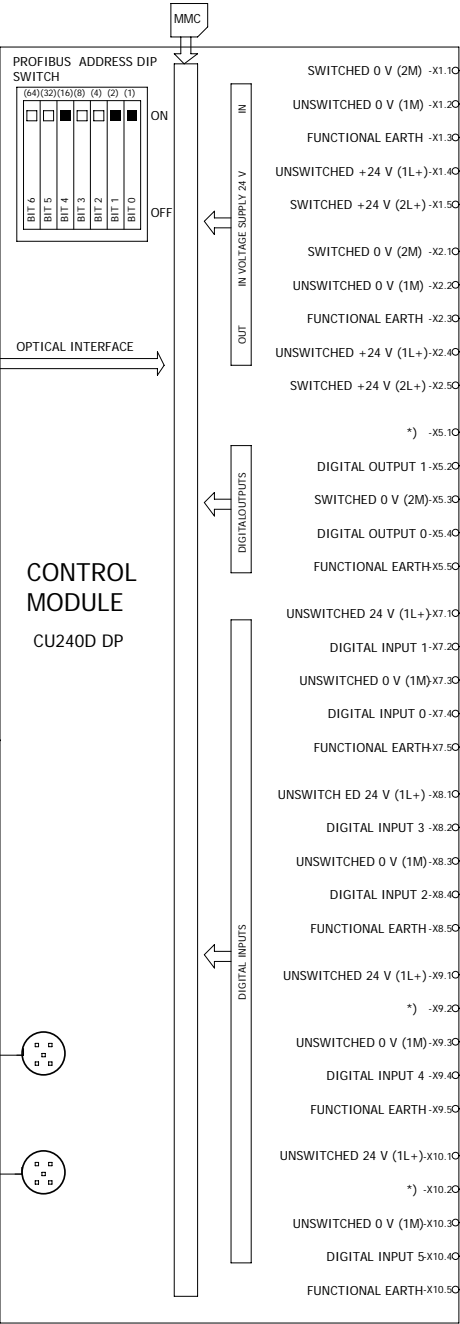
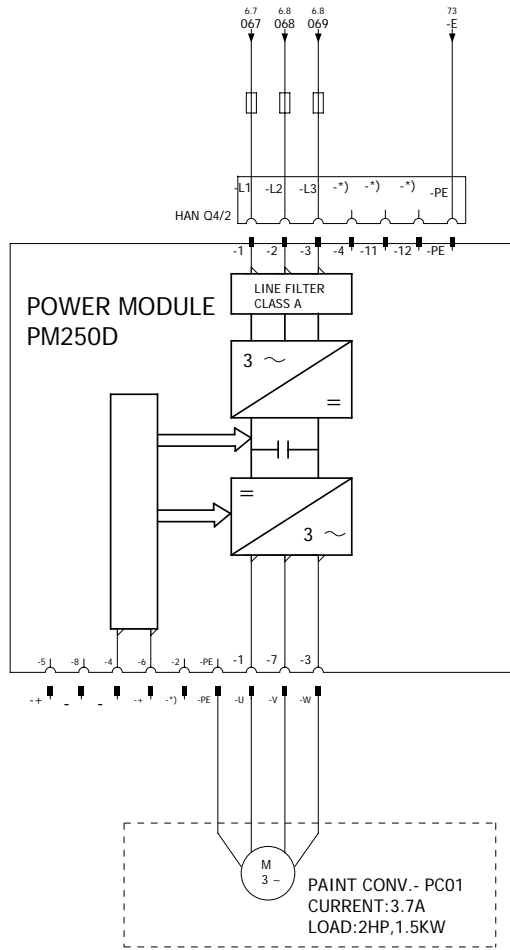

PROFIBUS DP interface IN FROM NODE-18

PROFIBUS DP interface OUT TO NODE-20

DOCUMENT ID : CY/DD/R/07
REV : 00



CYBERNETIK TECHNOLOGIES
PVT.LTD, PUNE

| | | |
|----------|------|--------|
| DRAWN | Date | Name |
| CHECKED | | SHITAL |
| APPROVED | | |

| | |
|---------------------|---------|
| PROJECT DESCRIPTION | TITLE |
| HA-382 VOLVO FRANCE | NODE-19 |

| | |
|-------------------|--------|
| PROJECT CODE :- | HA-382 |
| DRAWING NUMBER :- | |

| | |
|-------|-----|
| Page | 72 |
| Pages | 147 |

NODE-20 PC02
PAINT CONV. DRIVE

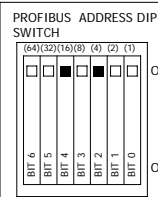
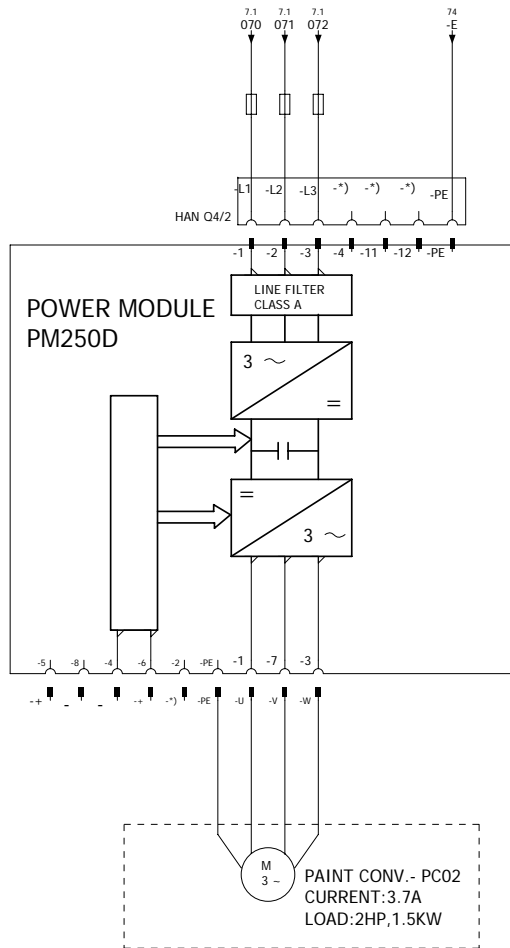

OPTICAL INTERFACE

CONTROL MODULE
CU240D DP

PM-IF INTERFACE

PROFIBUS DP interface IN FROM NODE-19

PROFIBUS DP interface OUT TO NODE-21

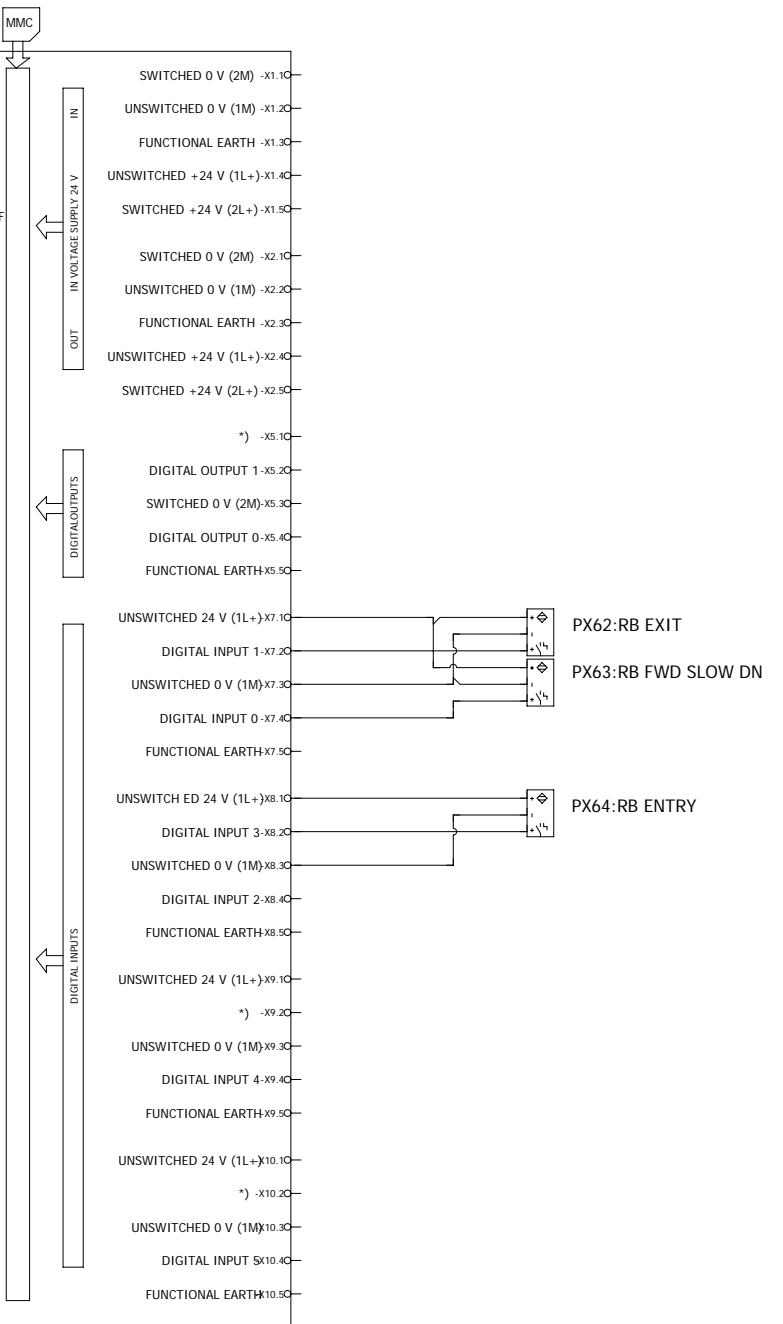

DOCUMENT ID : CY/DD/R/07

REV : 00

CYBERNETIK TECHNOLOGIES PVT.LTD, PUNE

| | |
|----------|--------|
| DATE | NAME |
| | SHITAL |
| CHECKED | |
| APPROVED | |

PROJECT DESCRIPTION
HA-382 VOLVO FRANCE

TITLE
NODE-20

PROJECT CODE :- HA-382
DRAWING NUMBER :-

NODE-21 RB11
ROLLER BED DRIVE

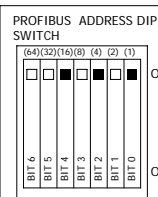
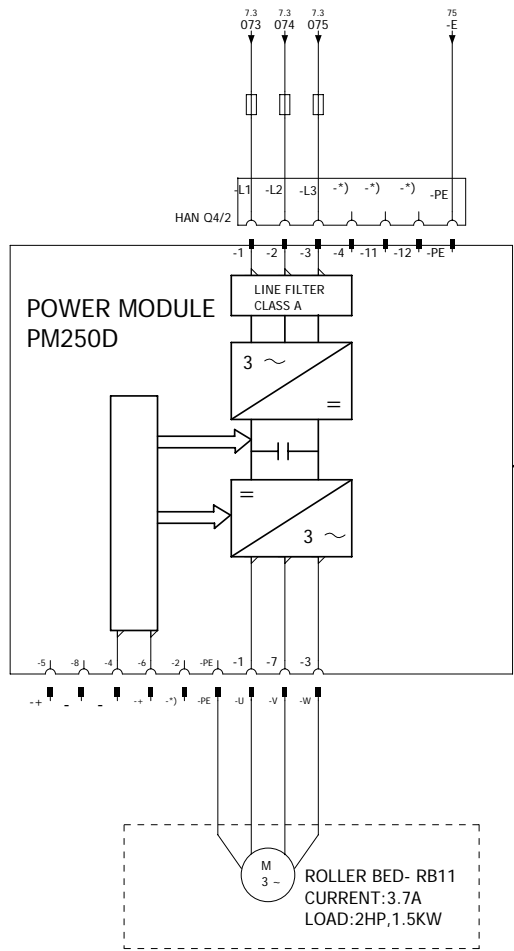

CONTROL MODULE
CU240D DP

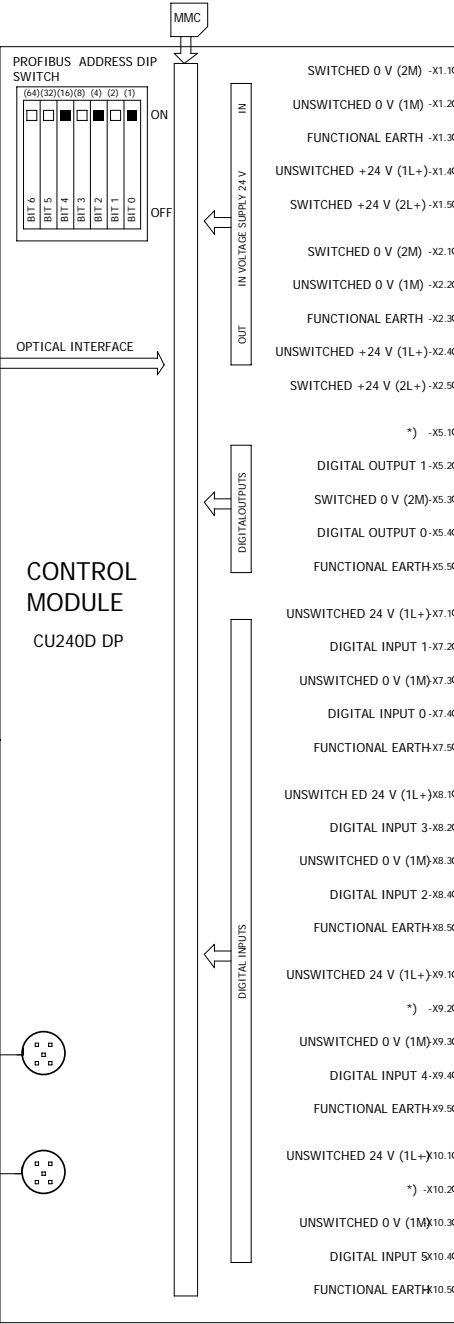

PM-IF INTERFACE

PROFIBUS DP interface IN FROM NODE-20

PROFIBUS DP interface OUT TO NODE-22

| | |
|----------|--------|
| DATE | NAME |
| | SHITAL |
| CHECKED | |
| APPROVED | |

| |
|---------------------|
| PROJECT DESCRIPTION |
| HA-382 VOLVO FRANCE |

| |
|---------|
| TITLE |
| NODE-21 |

| | |
|-------------------|--------|
| PROJECT CODE :- | HA-382 |
| DRAWING NUMBER :- | |
| Page | 74 |
| Pages | 147 |

NODE-22 RB12
ROLLER BED DRIVE

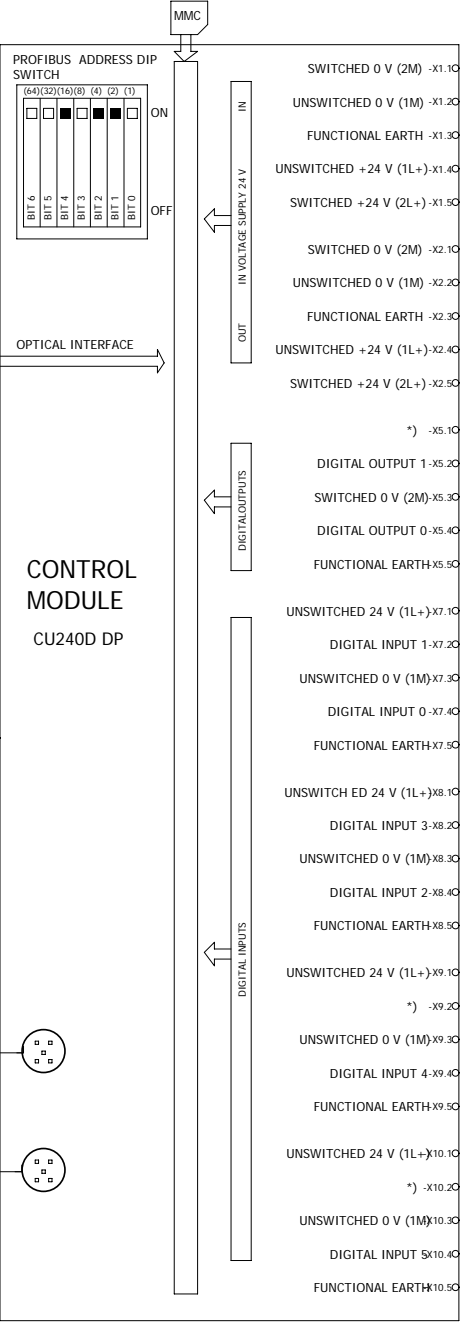
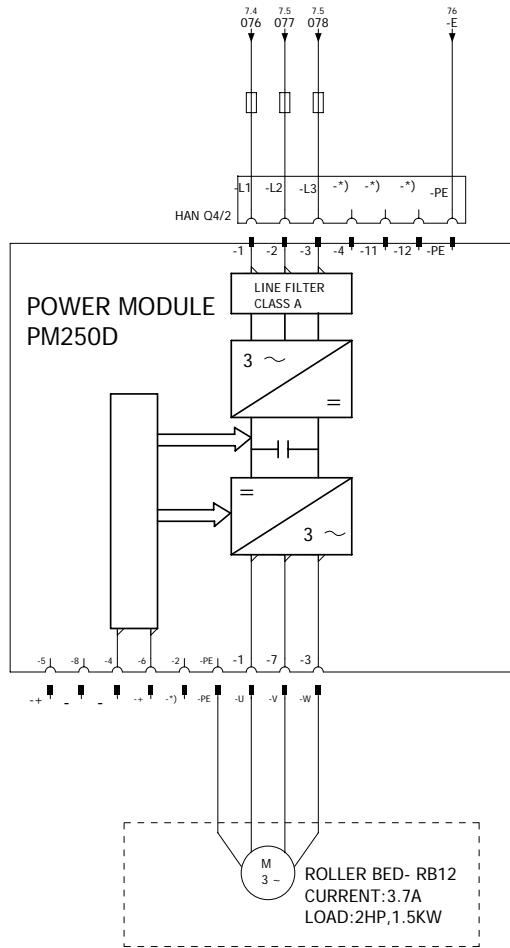

DOCUMENT ID : CY/DD/R/07
REV : 00



CYBERNETIK TECHNOLOGIES
PVT.LTD, PUNE

| | | |
|----------|------|--------|
| Drawn | Date | Name |
| Checked | | SHITAL |
| Approved | | |

| | |
|---------------------|---------|
| PROJECT DESCRIPTION | TITLE |
| HA-382 VOLVO FRANCE | NODE-22 |

| | |
|-------------------|--------|
| PROJECT CODE :- | HA-382 |
| DRAWING NUMBER :- | |

| | |
|-------|-----|
| Page | 75 |
| Pages | 147 |

NODE-23 RB13
ROLLER BED DRIVE

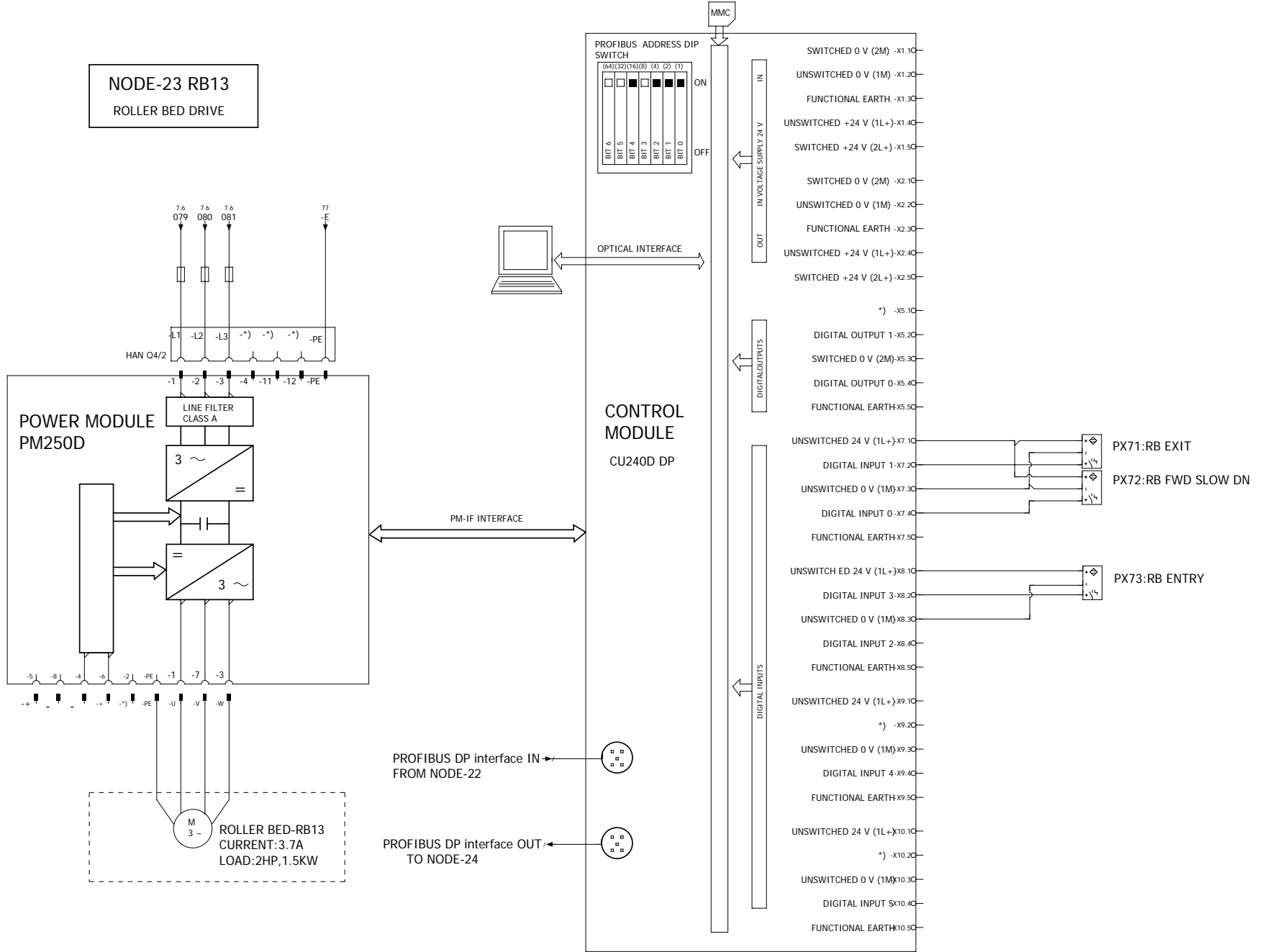

DOCUMENT ID : CY/DD/R/07
REV : 00

| | | |
|----------|------|--------|
| Drawn | Date | Name |
| Checked | | SHITAL |
| Approved | | |

| | |
|----------------------------|--------------|
| PROJECT DESCRIPTION | TITLE |
| HA-382 VOLVO FRANCE | NODE-23 |

| | |
|--------------------------|---------------|
| PROJECT CODE :- | HA-382 |
| DRAWING NUMBER :- | |

NODE-24 RB14
ROLLER BED DRIVE

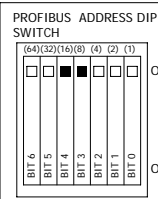
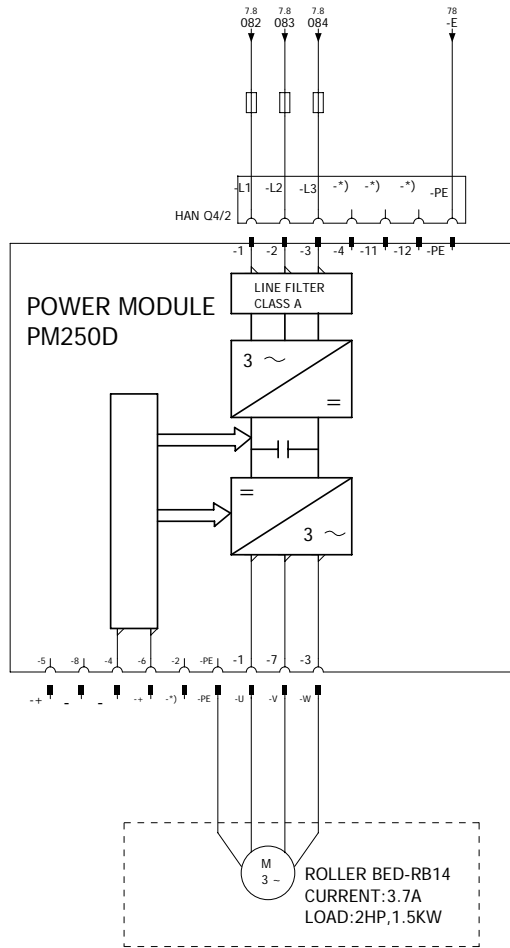

CONTROL MODULE
CU240D DP

PM-IF INTERFACE

PROFIBUS DP interface IN FROM NODE-23

PROFIBUS DP interface OUT TO NODE-25

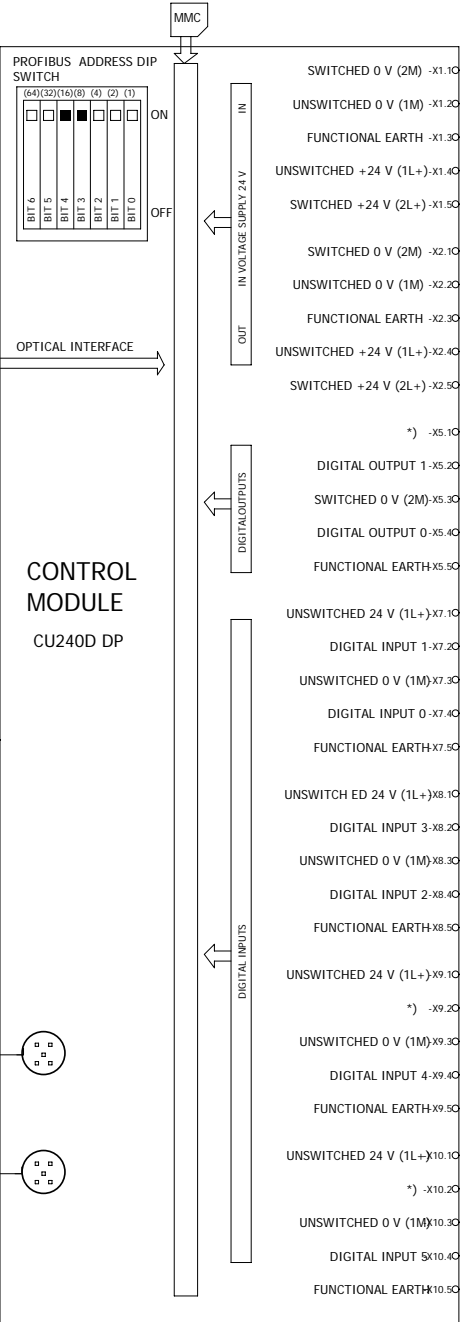

| | Date | Name |
|----------|------|--------|
| DRAWN | | SHITAL |
| CHECKED | | |
| APPROVED | | |

| PROJECT DESCRIPTION | TITLE |
|---------------------|---------|
| HA-382 VOLVO FRANCE | NODE-24 |

| PROJECT CODE :- | DRAWING NUMBER :- |
|-----------------|-------------------|
| HA-382 | |

| Page | Pages |
|------|-------|
| 77 | 147 |

NODE-25 RB15
ROLLER BED DRIVE

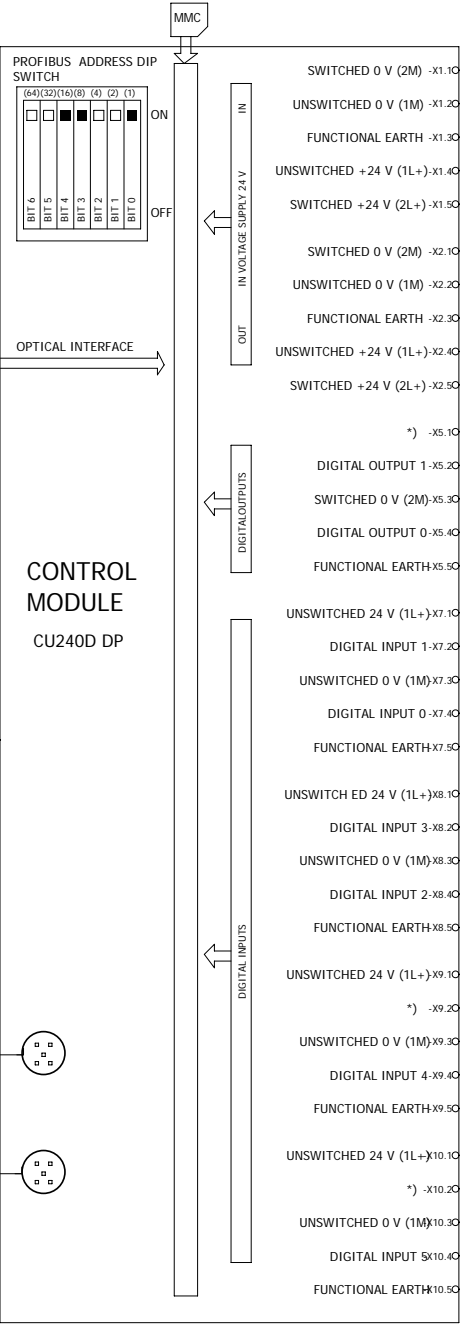
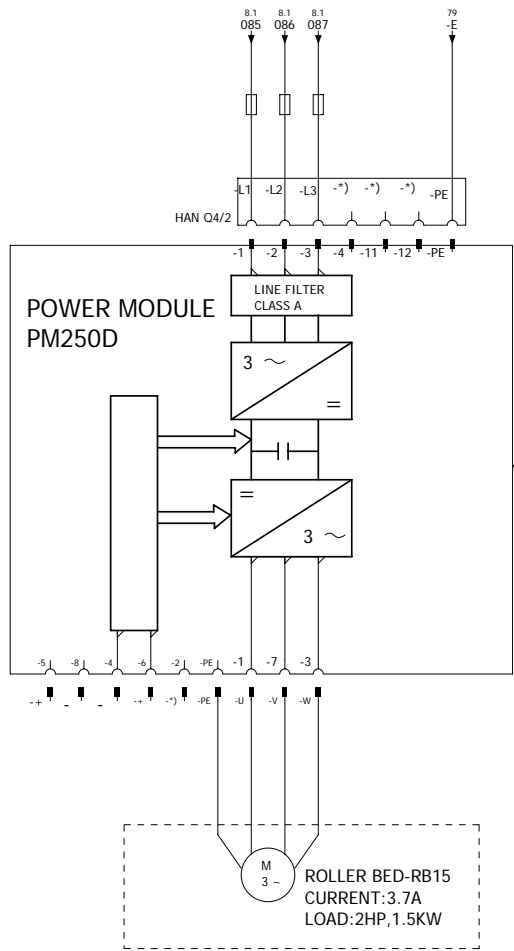

PROFIBUS DP interface IN FROM NODE-24

PROFIBUS DP interface OUT TO NODE-26

DOCUMENT ID : CY/DD/R/07
REV : 00



CYBERNETIK TECHNOLOGIES
PVT.LTD, PUNE

| | Date | Name |
|----------|------|--------|
| DRAWN | | SHITAL |
| CHECKED | | |
| APPROVED | | |

| PROJECT DESCRIPTION | TITLE |
|---------------------|---------|
| HA-382 VOLVO FRANCE | NODE-25 |

| PROJECT CODE :- | DRAWING NUMBER :- |
|-----------------|-------------------|
| HA-382 | |

| Page | Pages |
|------|-------|
| 78 | 147 |

NODE-26 RB16
ROLLER BED DRIVE

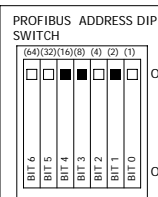
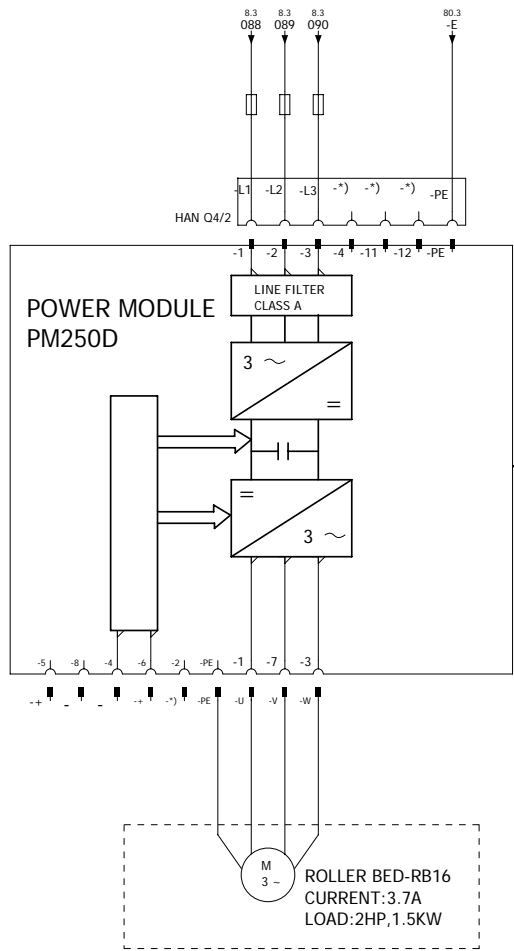

CONTROL MODULE
CU240D DP

PM-IF INTERFACE

PROFIBUS DP interface IN FROM NODE-25

PROFIBUS DP interface OUT TO NODE-27

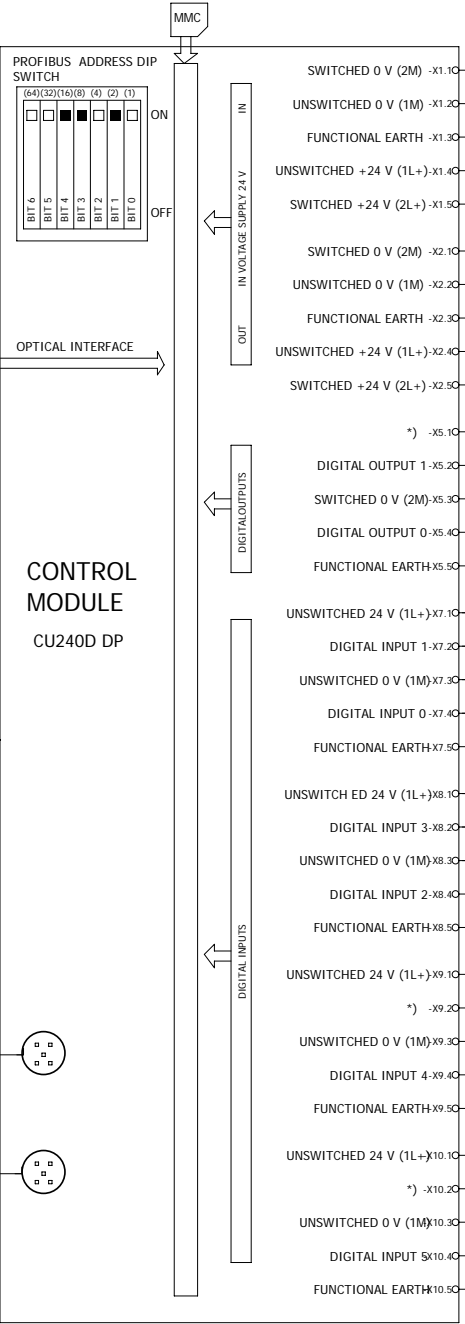

DOCUMENT ID : CY/DD/R/07

REV : 00



CYBERNETIK TECHNOLOGIES
PVT.LTD, PUNE

| | Date | Name |
|----------|------|--------|
| DRAWN | | SHITAL |
| CHECKED | | |
| APPROVED | | |

| PROJECT DESCRIPTION | TITLE |
|---------------------|---------|
| HA-382 VOLVO FRANCE | NODE-26 |

| PROJECT CODE :- | DRAWING NUMBER :- |
|-----------------|-------------------|
| HA-382 | |

| Page | Pages |
|------|-------|
| 79 | 147 |

NODE-27 RB17
ROLLER BED DRIVE

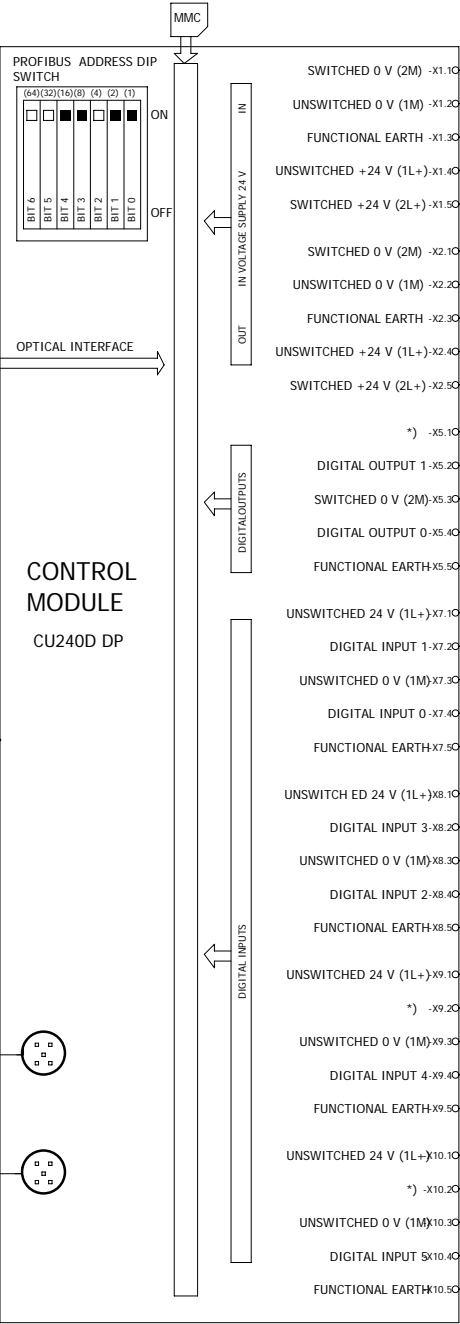
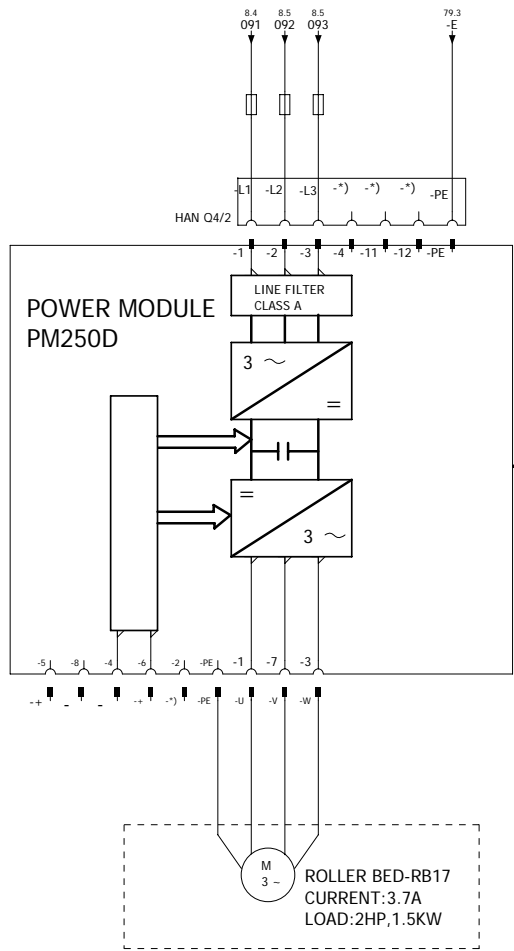

PM-IF INTERFACE

PROFIBUS DP interface IN FROM NODE-26

PROFIBUS DP interface OUT TO NODE-28

DOCUMENT ID : CY/DD/R/07
REV : 00

| | | |
|----------|------|--------|
| Drawn | Date | Name |
| Checked | | SHITAL |
| Approved | | |

| | |
|---------------------|---------|
| PROJECT DESCRIPTION | TITLE |
| HA-382 VOLVO FRANCE | NODE-27 |

| | |
|-------------------|--------|
| PROJECT CODE :- | HA-382 |
| DRAWING NUMBER :- | |

NODE-28 RB18
ROLLER BED DRIVE

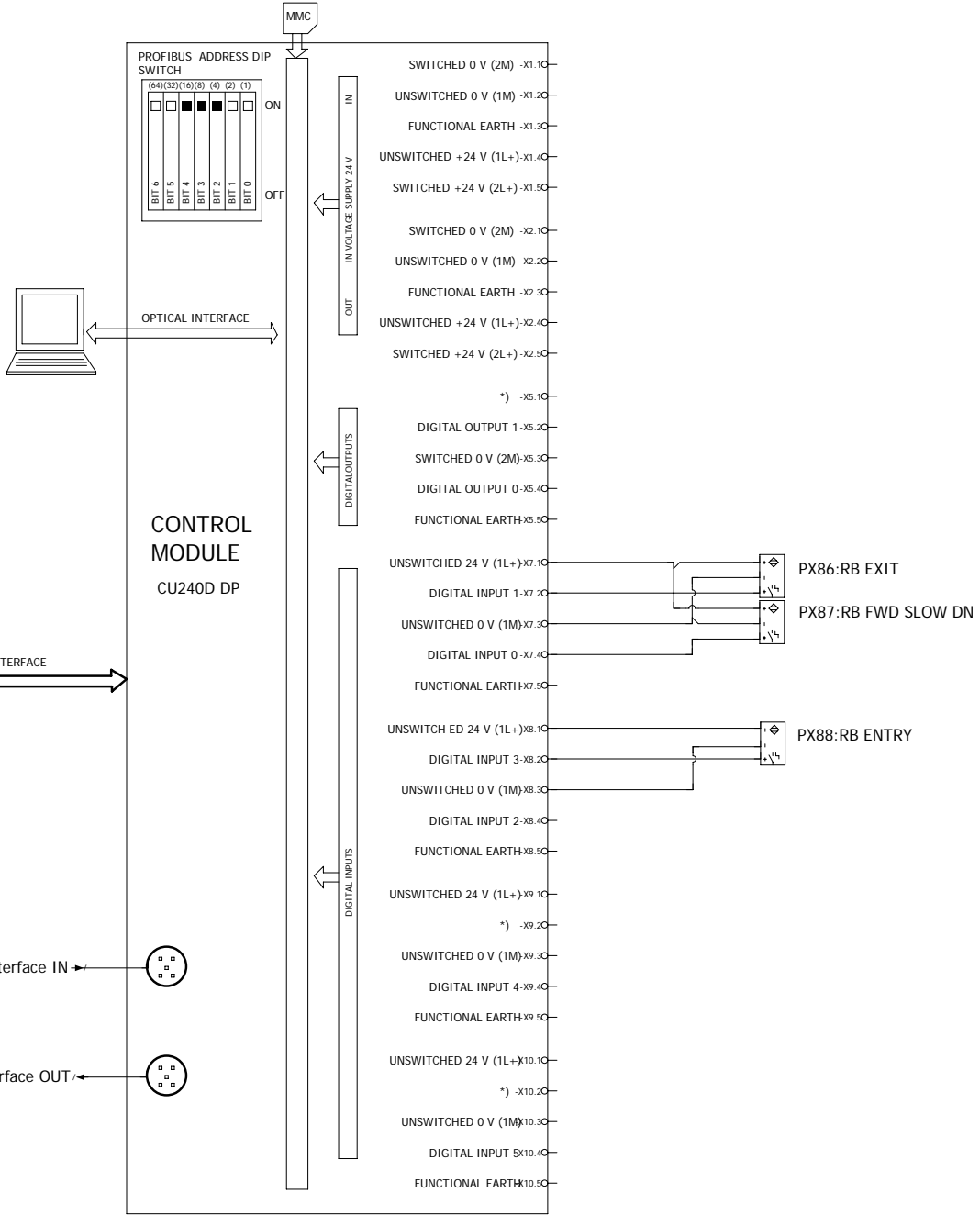
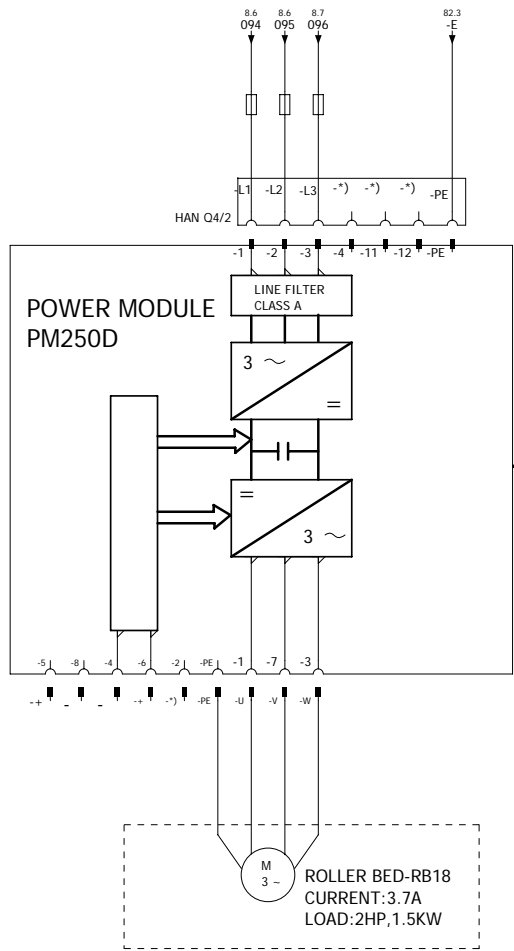

DOCUMENT ID : CY/DD/R/07
REV : 00



CYBERNETIK TECHNOLOGIES
PVT.LTD, PUNE

| | Date | Name |
|----------|------|--------|
| DRAWN | | SHITAL |
| CHECKED | | |
| APPROVED | | |

| PROJECT DESCRIPTION | TITLE |
|---------------------|---------|
| HA-382 VOLVO FRANCE | NODE-28 |

| PROJECT CODE :- | DRAWING NUMBER :- |
|-----------------|-------------------|
| HA-382 | |

| Page | Pages |
|------|-------|
| 81 | 147 |

NODE-29 RB19
ROLLER BED DRIVE

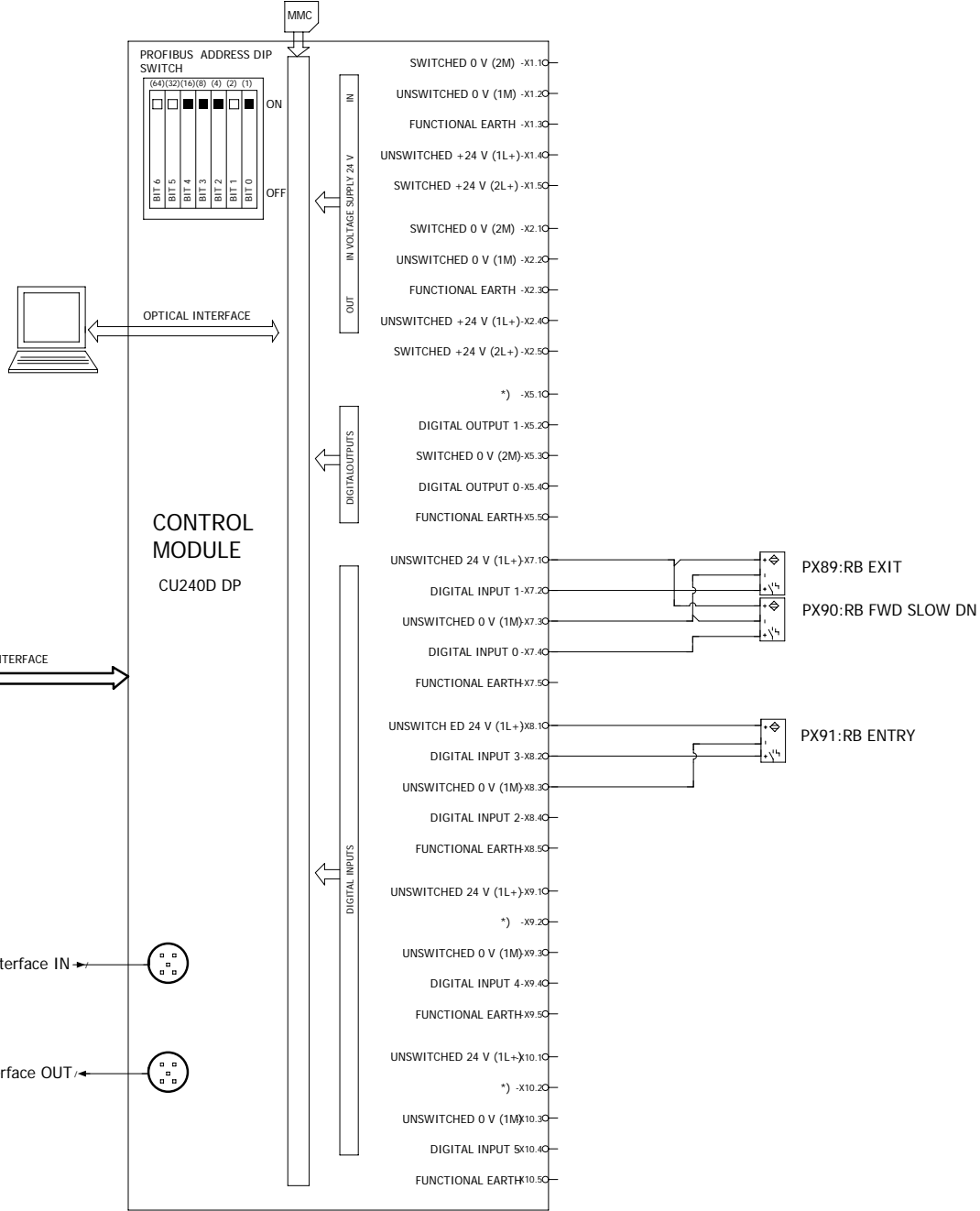
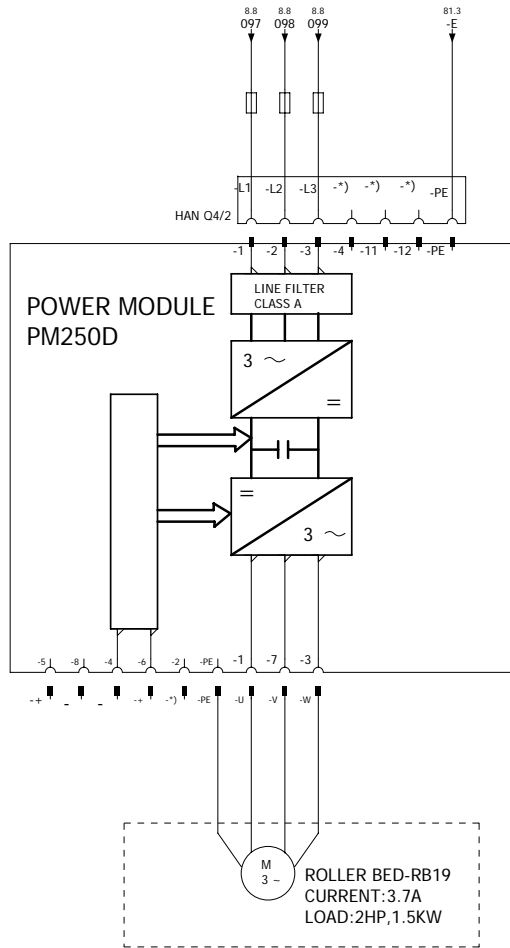

DOCUMENT ID : CY/DD/R/07
REV : 00

| | | |
|----------|------|--------|
| Drawn | Date | Name |
| Checked | | SHITAL |
| Approved | | |

| | |
|---------------------|---------|
| PROJECT DESCRIPTION | TITLE |
| HA-382 VOLVO FRANCE | NODE-29 |

| | |
|-------------------|--------|
| PROJECT CODE :- | HA-382 |
| DRAWING NUMBER :- | |

NODE-30 RB20
ROLLER BED DRIVE

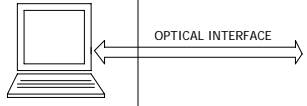
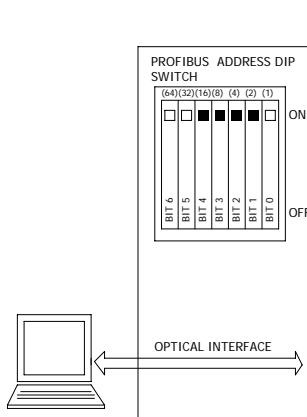
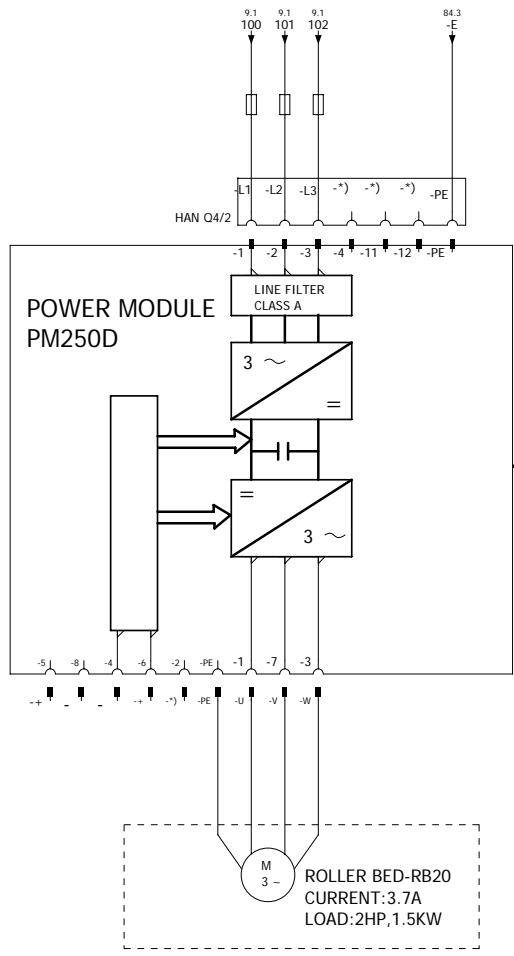

CONTROL MODULE
CU240D DP

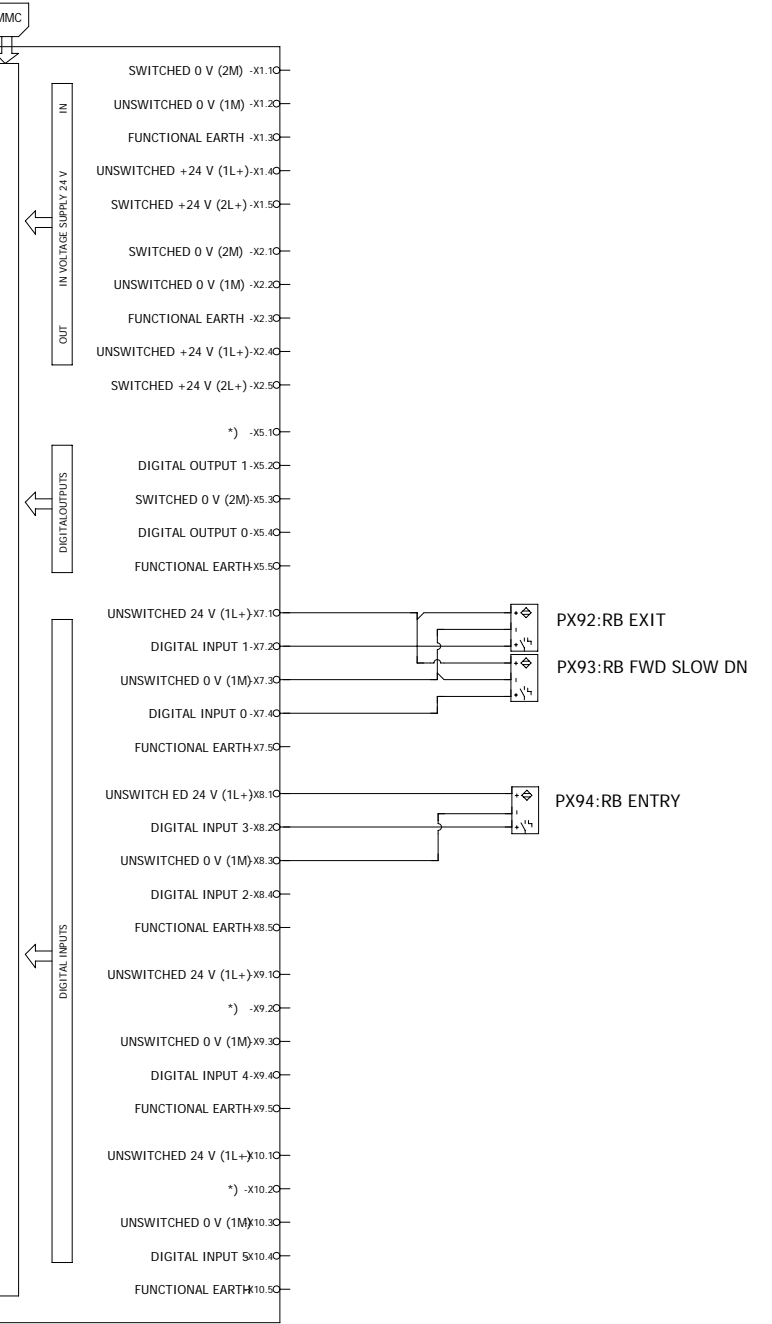
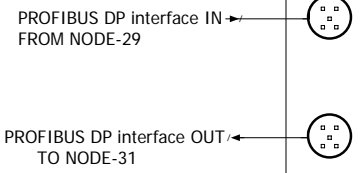
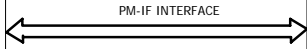

| | |
|----------|--------|
| DATE | NAME |
| | SHITAL |
| CHECKED | |
| APPROVED | |

| | |
|---------------------|---------|
| PROJECT DESCRIPTION | TITLE |
| HA-382 VOLVO FRANCE | NODE-30 |

| | |
|-------------------|--------|
| PROJECT CODE :- | HA-382 |
| DRAWING NUMBER :- | |

NODE-31 RB21
ROLLER BED DRIVE

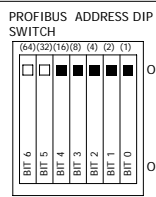
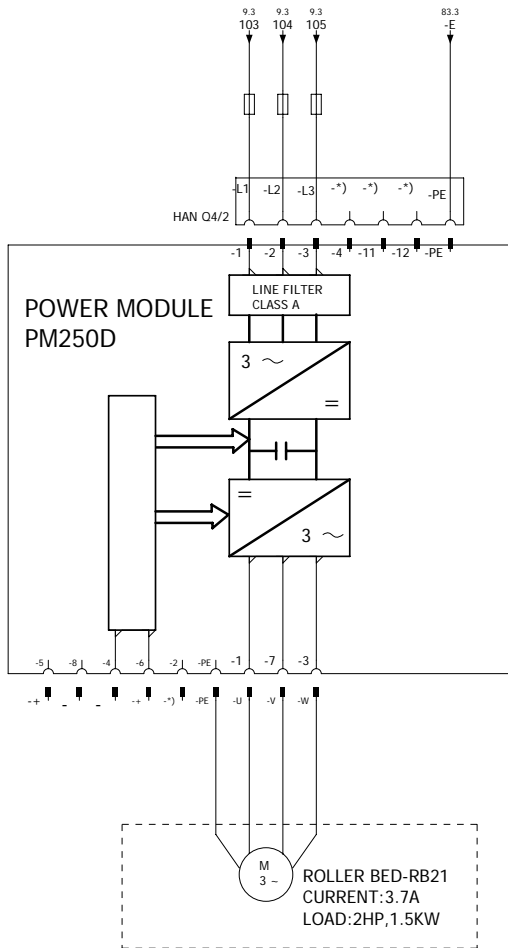

OPTICAL INTERFACE

CONTROL MODULE
CU240D DP

PM-IF INTERFACE

PROFIBUS DP interface IN FROM NODE-30

PROFIBUS DP interface OUT TO NODE-32

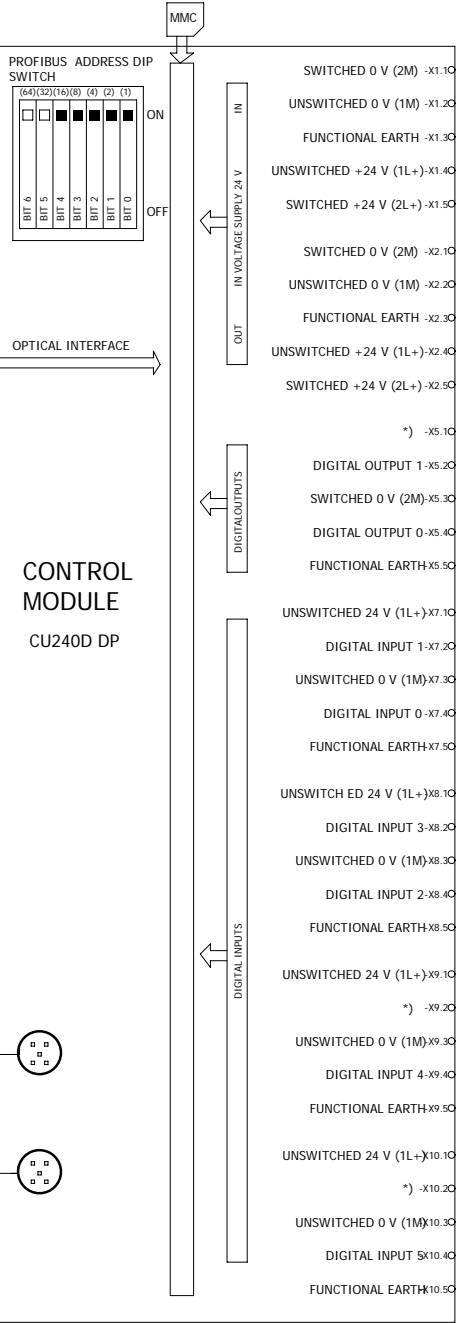

| | Date | Name |
|----------|------|--------|
| DRAWN | | SHITAL |
| CHECKED | | |
| APPROVED | | |

| PROJECT DESCRIPTION | TITLE |
|---------------------|---------|
| HA-382 VOLVO FRANCE | NODE-31 |

| PROJECT CODE :- | DRAWING NUMBER :- |
|-----------------|-------------------|
| HA-382 | |

| Page | Pages |
|------|-------|
| 84 | 147 |

NODE-32 RB22
ROLLER BED DRIVE

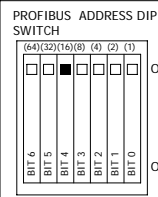
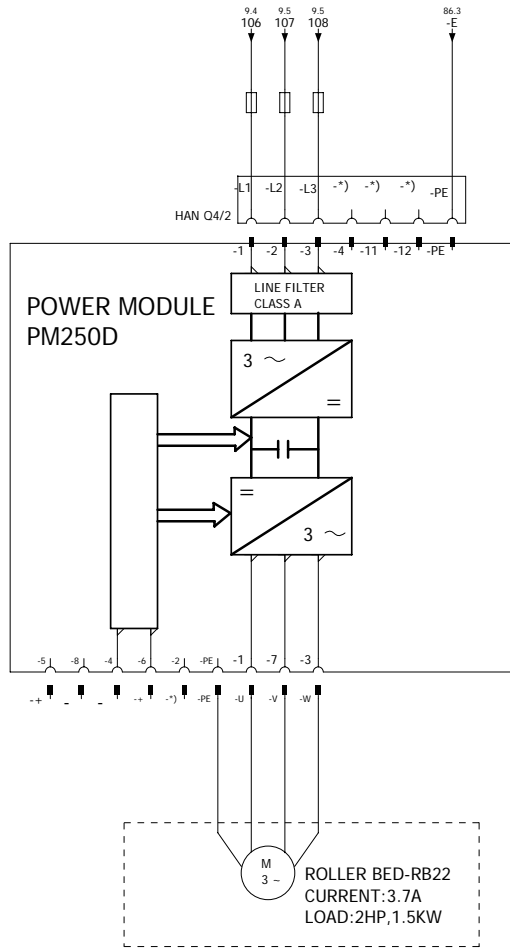

OPTICAL INTERFACE

CONTROL MODULE
CU240D DP

PM-IF INTERFACE

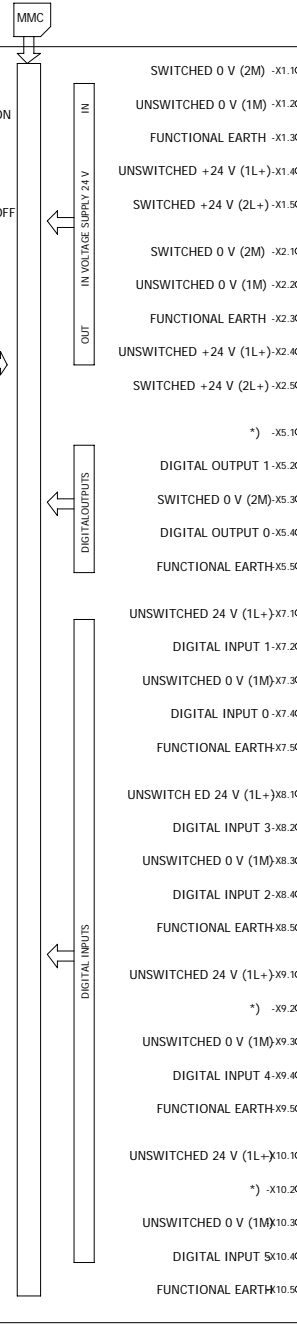
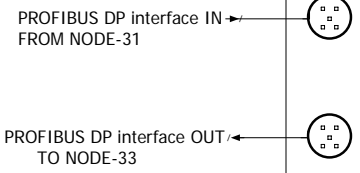

| | Date | Name |
|----------|------|--------|
| DRAWN | | SHITAL |
| CHECKED | | |
| APPROVED | | |

| PROJECT DESCRIPTION | TITLE |
|---------------------|---------|
| HA-382 VOLVO FRANCE | NODE-32 |

| PROJECT CODE :- | DRAWING NUMBER :- |
|-----------------|-------------------|
| HA-382 | |

| Page | Pages |
|------|-------|
| 85 | 147 |

NODE-33 RB23
ROLLER BED DRIVE

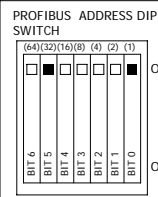
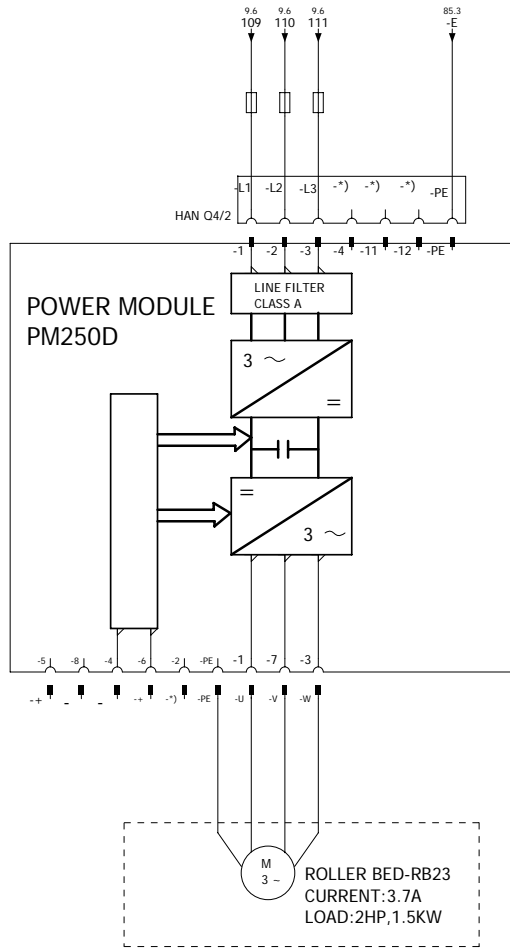

CONTROL MODULE
CU240D DP

PM-IF INTERFACE

PROFIBUS DP interface IN FROM NODE-32

PROFIBUS DP interface OUT TO NODE-34

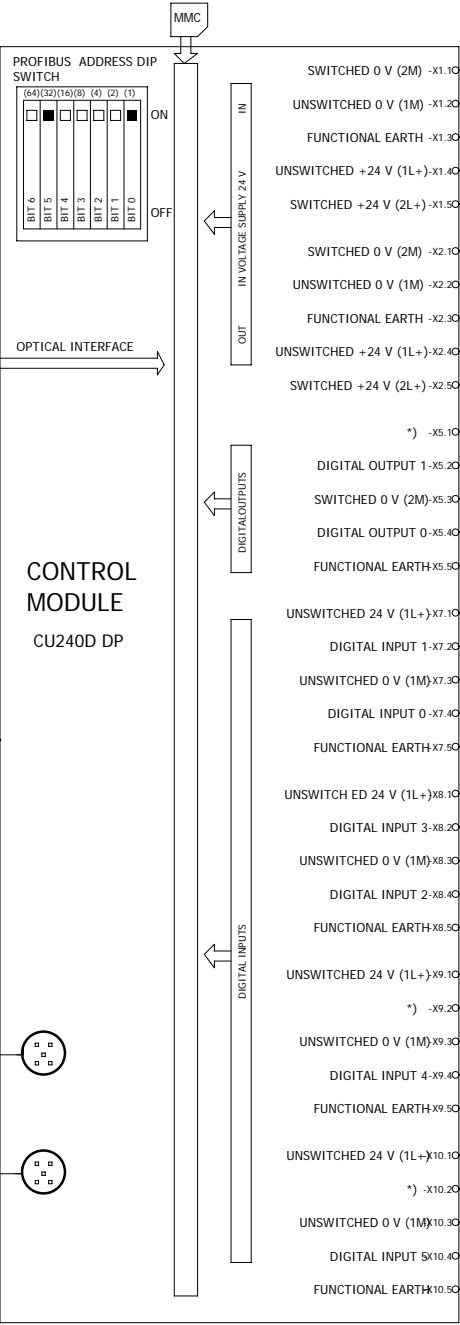

| | | |
|----------|------|--------|
| Drawn | Date | Name |
| Checked | | SHITAL |
| Approved | | |

| | |
|----------------------------|--------------|
| PROJECT DESCRIPTION | TITLE |
| HA-382 VOLVO FRANCE | NODE-33 |

| | |
|--------------------------|---------------|
| PROJECT CODE :- | HA-382 |
| DRAWING NUMBER :- | |

NODE-34 RB24
ROLLER BED DRIVE

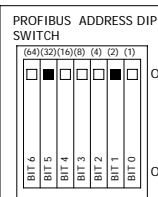
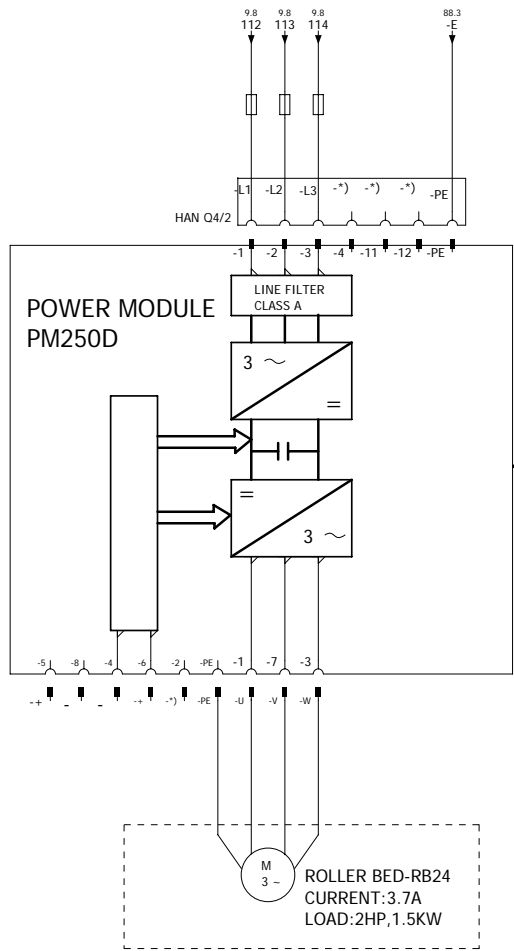

OPTICAL INTERFACE

CONTROL MODULE
CU240D DP

PM-IF INTERFACE

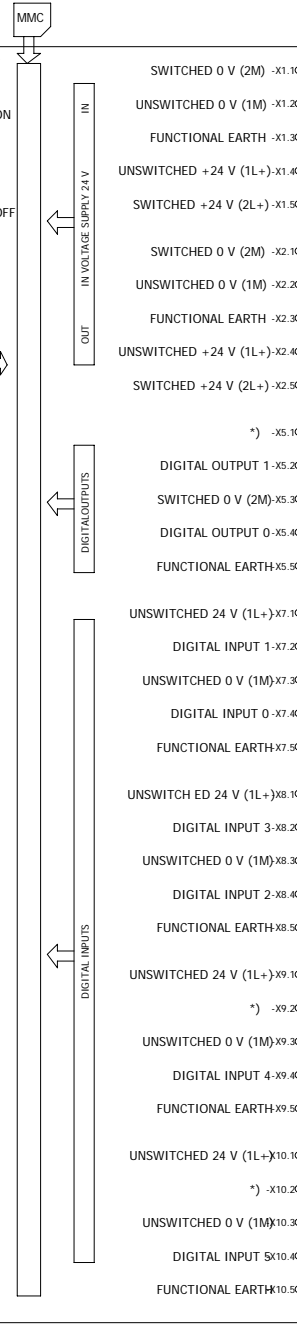
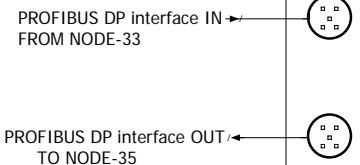

| | |
|----------|--------|
| DATE | NAME |
| | SHITAL |
| CHECKED | |
| APPROVED | |

| | |
|---------------------|---------|
| PROJECT DESCRIPTION | TITLE |
| HA-382 VOLVO FRANCE | NODE-34 |

| | |
|-------------------|--------|
| PROJECT CODE :- | HA-382 |
| DRAWING NUMBER :- | |

NODE-35 RB25
ROLLER BED DRIVE

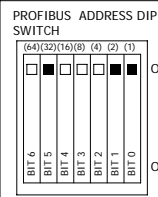
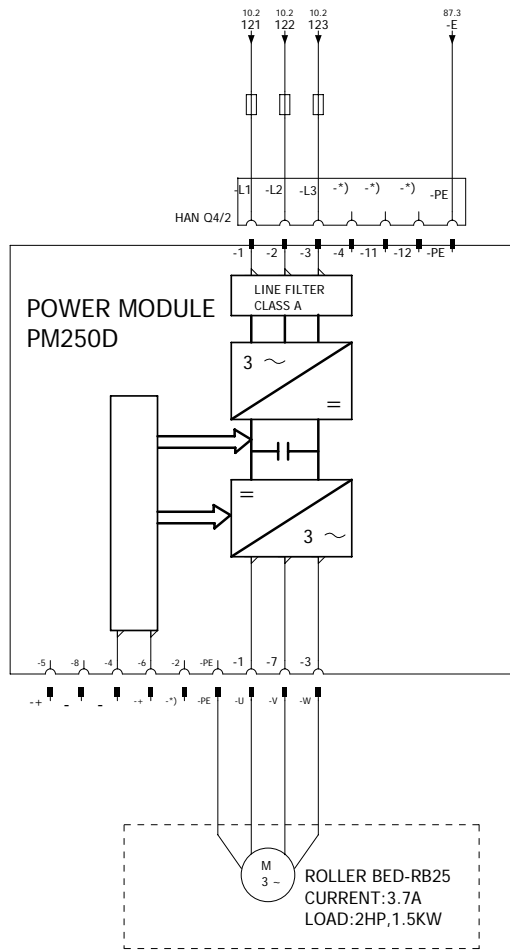

CONTROL MODULE
CU240D DP

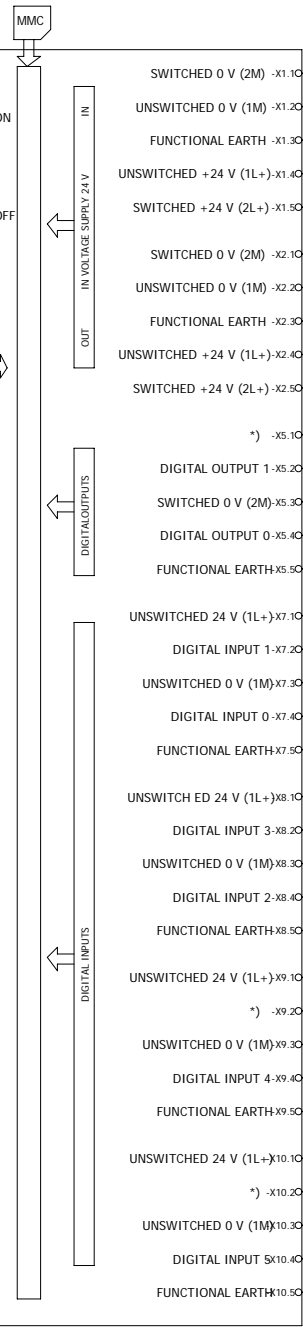

PM-IF INTERFACE

PROFIBUS DP interface IN FROM NODE-34

PROFIBUS DP interface OUT TO NODE-36



| | |
|----------|--------|
| DATE | NAME |
| CHECKED | SHITAL |
| APPROVED | |

| | |
|---------------------|---------|
| PROJECT DESCRIPTION | TITLE |
| HA-382 VOLVO FRANCE | NODE-35 |

| | |
|-------------------|--------|
| PROJECT CODE :- | HA-382 |
| DRAWING NUMBER :- | |

NODE-36 RB26
ROLLER BED DRIVE

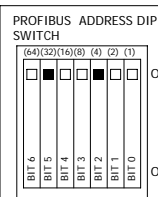
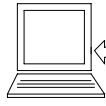
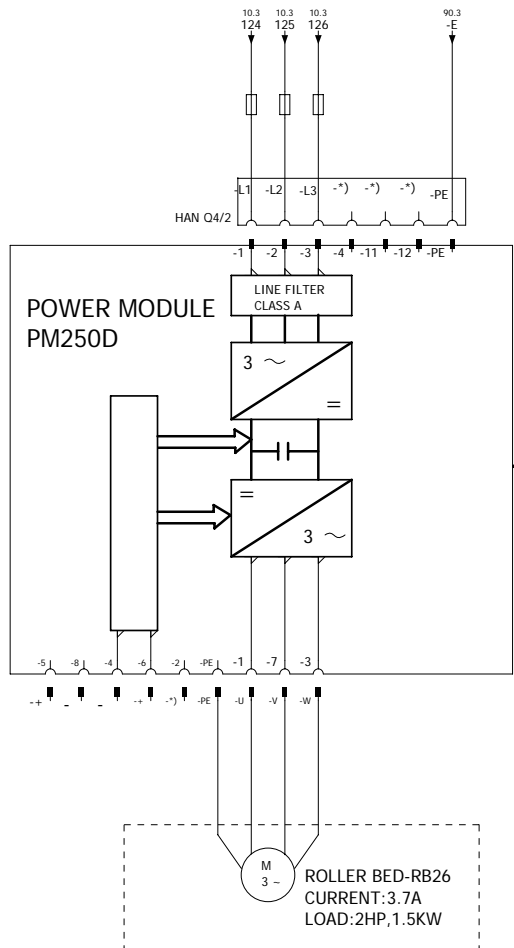

OPTICAL INTERFACE

CONTROL MODULE
CU240D DP

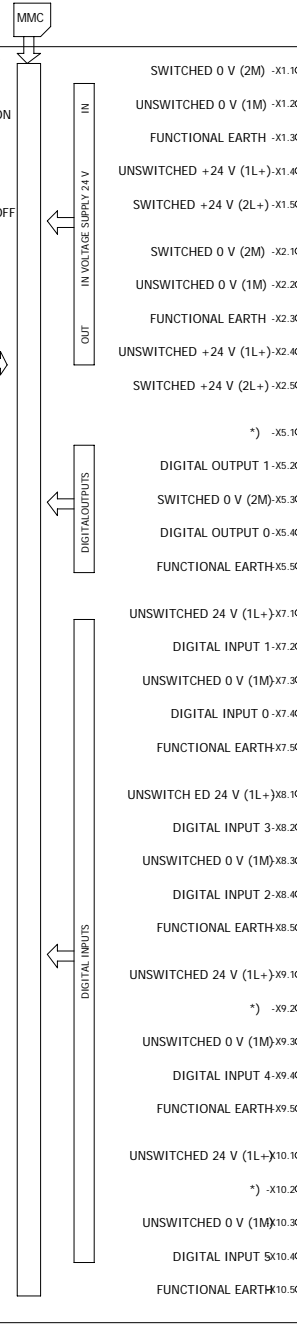

PM-IF INTERFACE

PROFIBUS DP interface IN FROM NODE-35

PROFIBUS DP interface OUT TO NODE-37

ROLLER BED-RB26
CURRENT:3.7A
LOAD:2HP,1.5KW



| | Date | Name |
|----------|------|--------|
| DRAWN | | SHITAL |
| CHECKED | | |
| APPROVED | | |

| PROJECT DESCRIPTION | TITLE |
|---------------------|---------|
| HA-382 VOLVO FRANCE | NODE-36 |

| PROJECT CODE :- | DRAWING NUMBER :- |
|-----------------|-------------------|
| HA-382 | |

| Page | Pages |
|------|-------|
| 89 | 147 |

NODE-37 RBSL03-A
ROLLER BED DRIVE

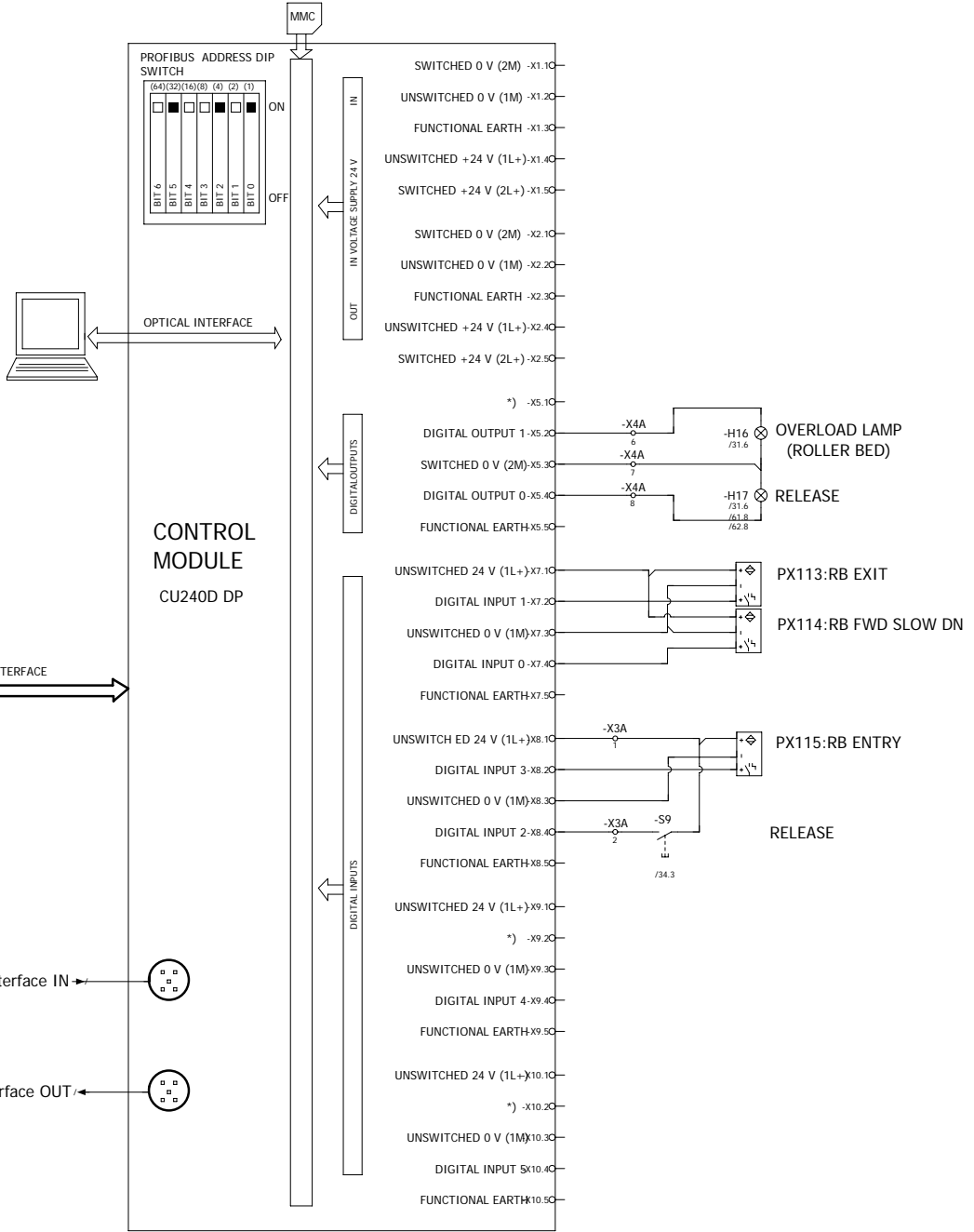
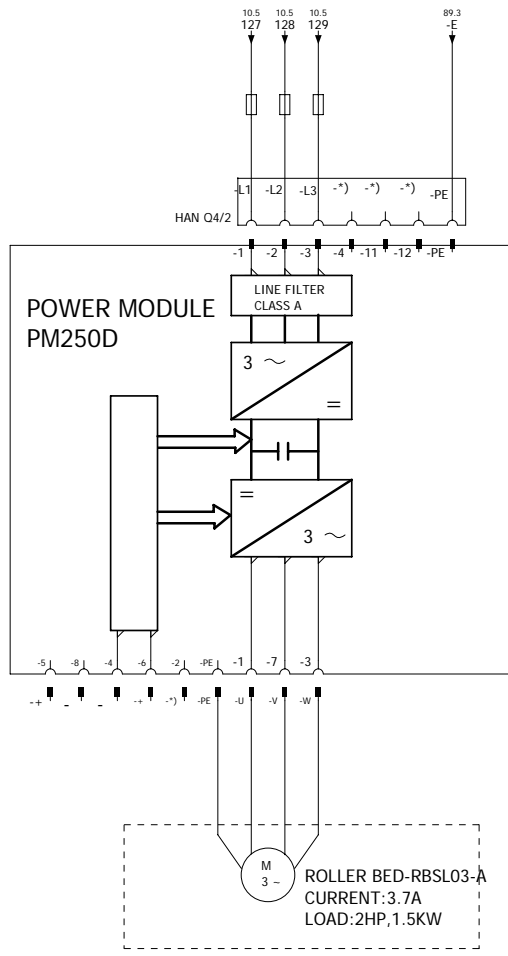

PROFIBUS DP interface IN FROM NODE-36

PROFIBUS DP interface OUT TO NODE-38

DOCUMENT ID : CY/DD/R/07

REV : 00



CYBERNETIK TECHNOLOGIES
PVT.LTD, PUNE

| | Date | Name |
|----------|------|--------|
| DRAWN | | SHITAL |
| CHECKED | | |
| APPROVED | | |

| PROJECT DESCRIPTION | TITLE |
|---------------------|---------|
| HA-382 VOLVO FRANCE | NODE-37 |

| PROJECT CODE :- | DRAWING NUMBER :- |
|-----------------|-------------------|
| HA-382 | |

| Page | Pages |
|------|-------|
| 90 | 147 |

NODE-38 RBSL03-B
LIFT MOTOR DRIVE

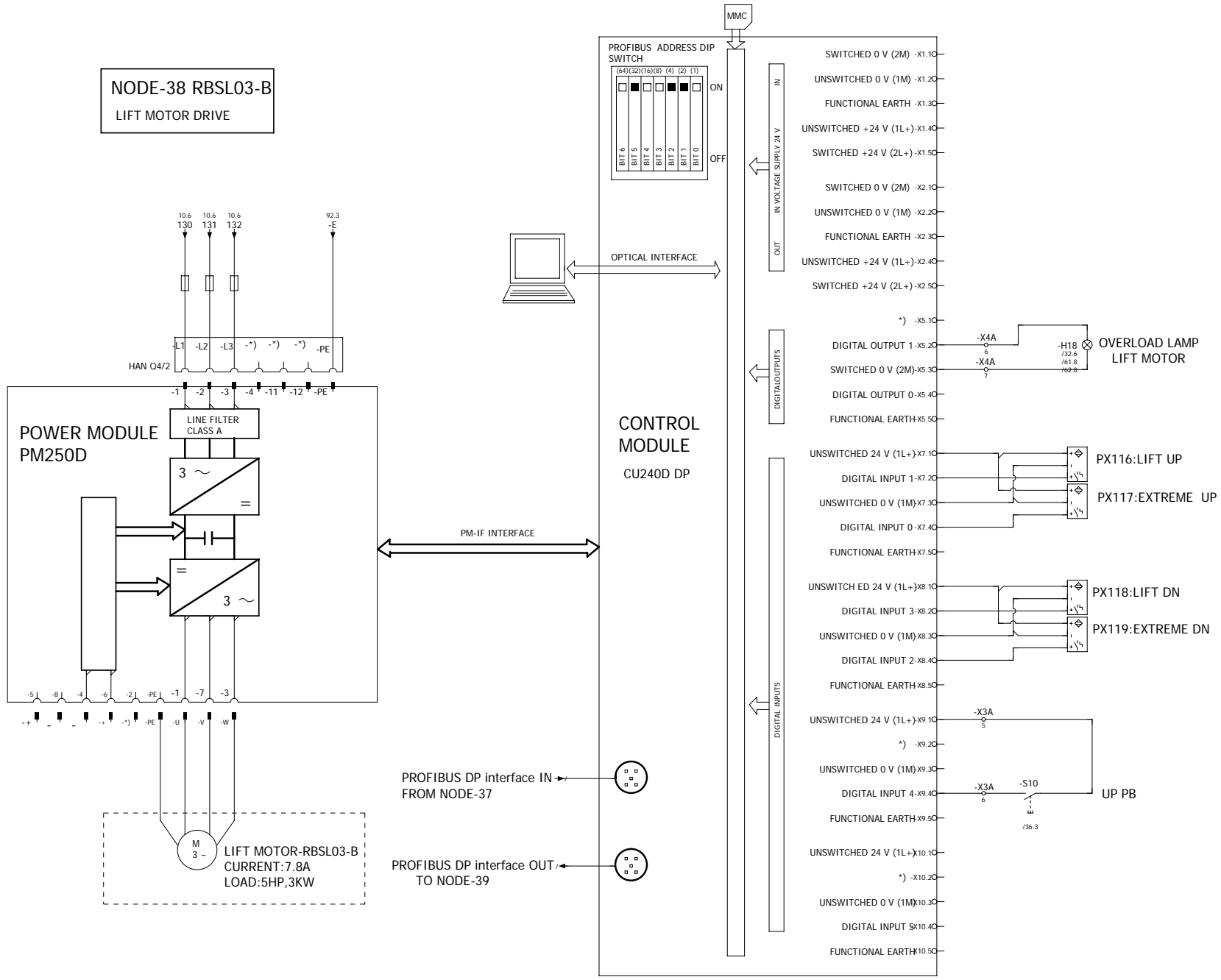

DOCUMENT ID : CY/DD/R/07
REV : 00

CYBERNETIK TECHNOLOGIES PVT.LTD, PUNE

| | | |
|----------|------|--------|
| DRAWN | Date | Name |
| CHECKED | | SHITAL |
| APPROVED | | |

| | |
|---------------------|---------------------|
| PROJECT DESCRIPTION | HA-382 VOLVO FRANCE |
|---------------------|---------------------|

| | |
|-------|---------|
| TITLE | NODE-38 |
|-------|---------|

| | |
|-------------------|---------------|
| PROJECT CODE :- | HA-382 |
| DRAWING NUMBER :- | |
| Page | 91 |
| Pages | 147 |

NODE-39 RBSL04-A
ROLLER BED DRIVE

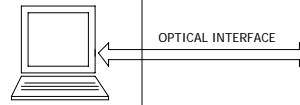
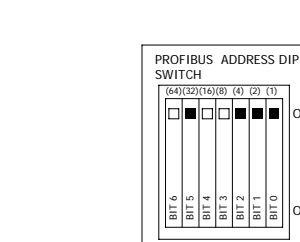
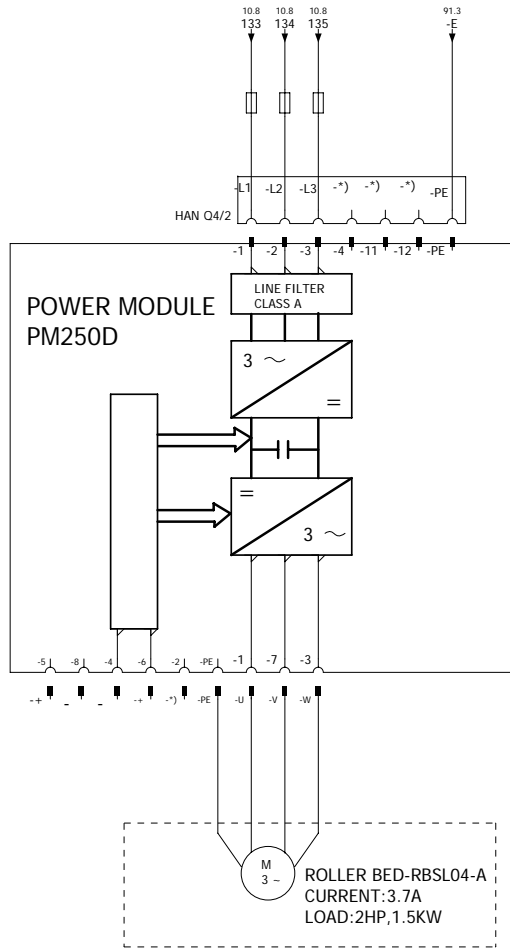

CONTROL MODULE
CU240D DP

PM-IF INTERFACE

PROFIBUS DP interface IN FROM NODE-38

PROFIBUS DP interface OUT TO NODE-40

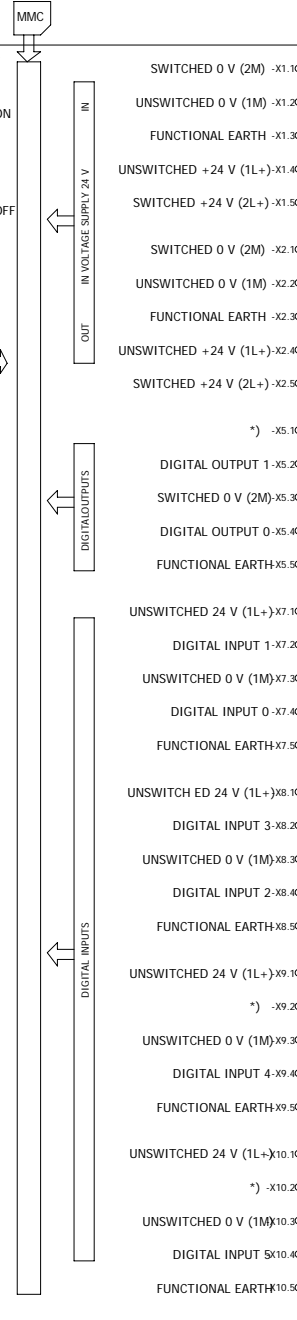

DOCUMENT ID : CY/DD/R/07
REV : 00

| | | |
|----------|------|--------|
| Drawn | Date | Name |
| Checked | | SHITAL |
| Approved | | |

| |
|----------------------------|
| PROJECT DESCRIPTION |
| HA-382 VOLVO FRANCE |

| |
|--------------|
| TITLE |
| NODE-39 |

| | |
|--------------------------|---------------|
| PROJECT CODE :- | HA-382 |
| DRAWING NUMBER :- | |

NODE-40 RBSL04-B
LIFT MOTOR DRIVE

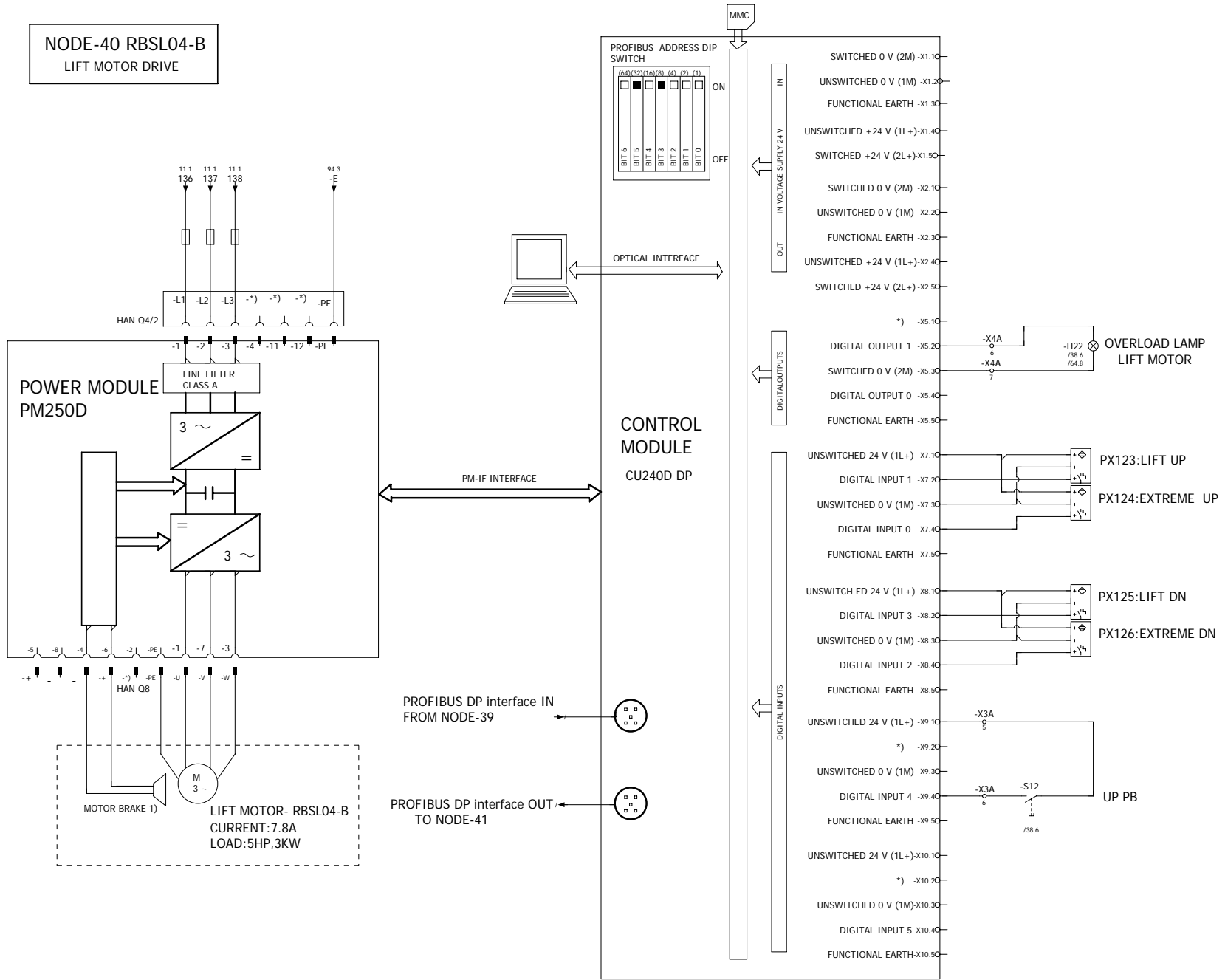

DOCUMENT ID : CY/DD/R/07
REV : 00

| | | |
|----------|------|--------|
| Drawn | Date | Name |
| Checked | | SHITAL |
| Approved | | |

| | |
|---------------------|---------|
| PROJECT DESCRIPTION | TITLE |
| HA-382 VOLVO FRANCE | NODE-40 |

| | |
|-------------------|--------|
| PROJECT CODE :- | HA-382 |
| DRAWING NUMBER :- | |

NODE-41 RB27
ROLLER BED DRIVE

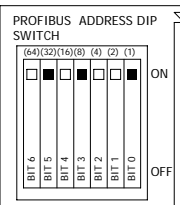
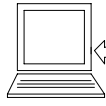
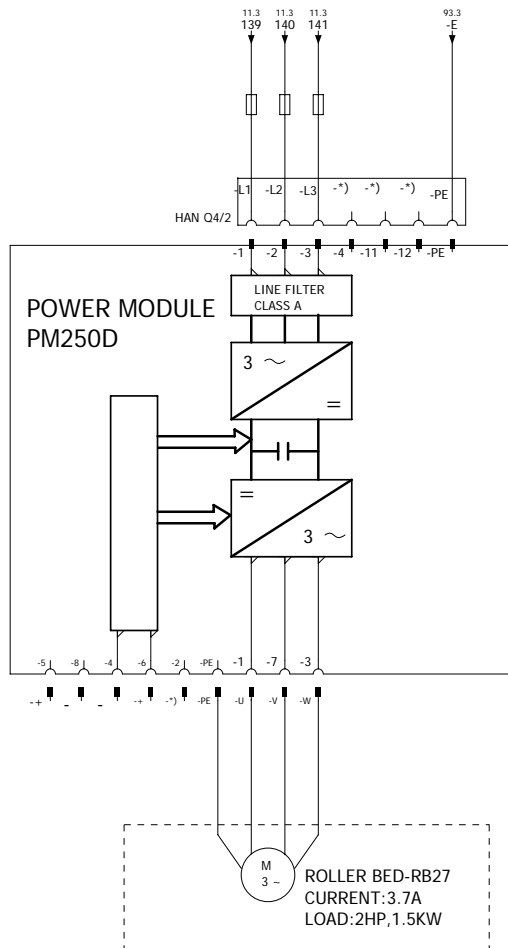

OPTICAL INTERFACE

CONTROL MODULE
CU240D DP

PM-IF INTERFACE

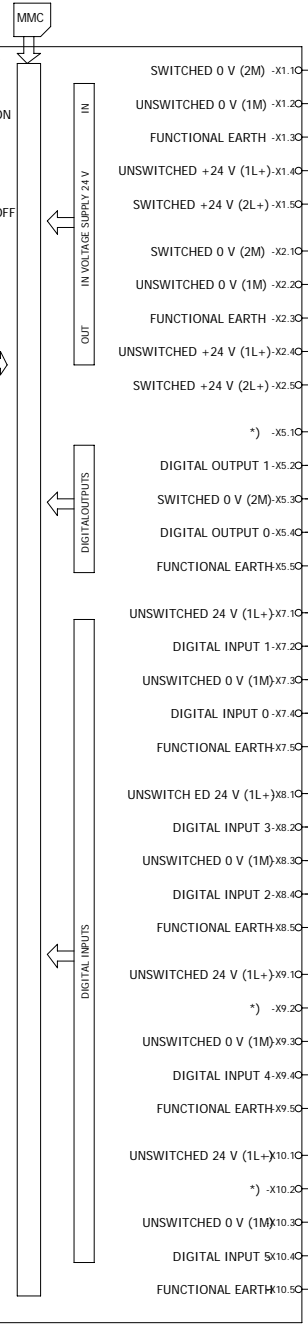
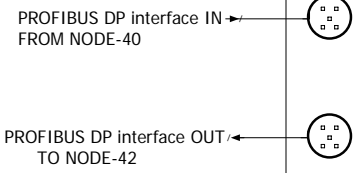

DOCUMENT ID : CY/DD/R/07

REV : 00



CYBERNETIK TECHNOLOGIES
PVT.LTD, PUNE

| | Date | Name |
|----------|------|--------|
| DRAWN | | SHITAL |
| CHECKED | | |
| APPROVED | | |

| PROJECT DESCRIPTION | TITLE |
|---------------------|---------|
| HA-382 VOLVO FRANCE | NODE-41 |

| PROJECT CODE:- | DRAWING NUMBER :- |
|----------------|-------------------|
| HA-382 | |

| Page | Pages |
|------|-------|
| 94 | 147 |

NODE-42 RB28
ROLLER BED DRIVE

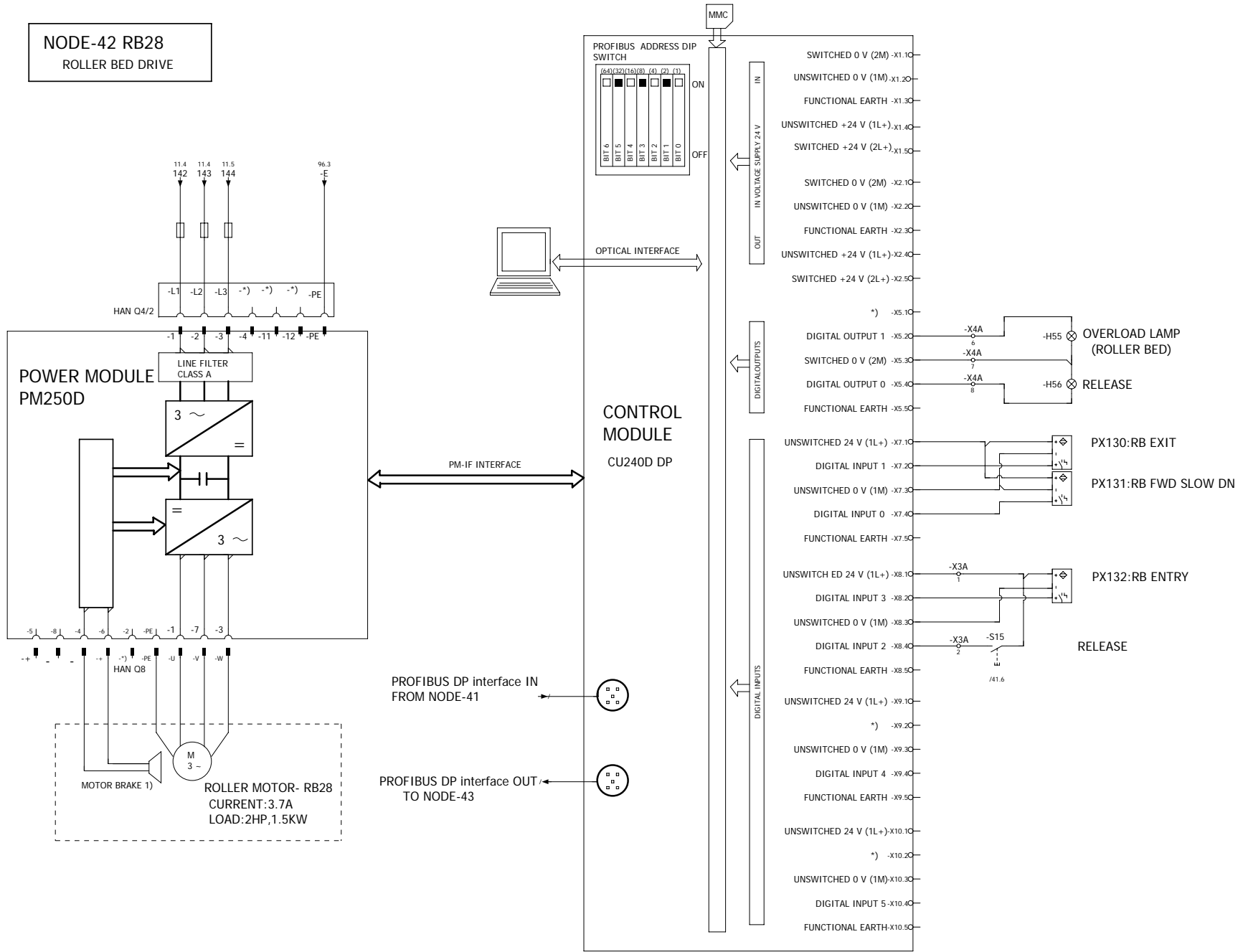

DOCUMENT ID : CY/DD/R/07
REV : 00

| | | |
|----------|------|--------|
| Drawn | Date | Name |
| Checked | | SHITAL |
| Approved | | |

NODE-43 RB29
ROLLER BED DRIVE

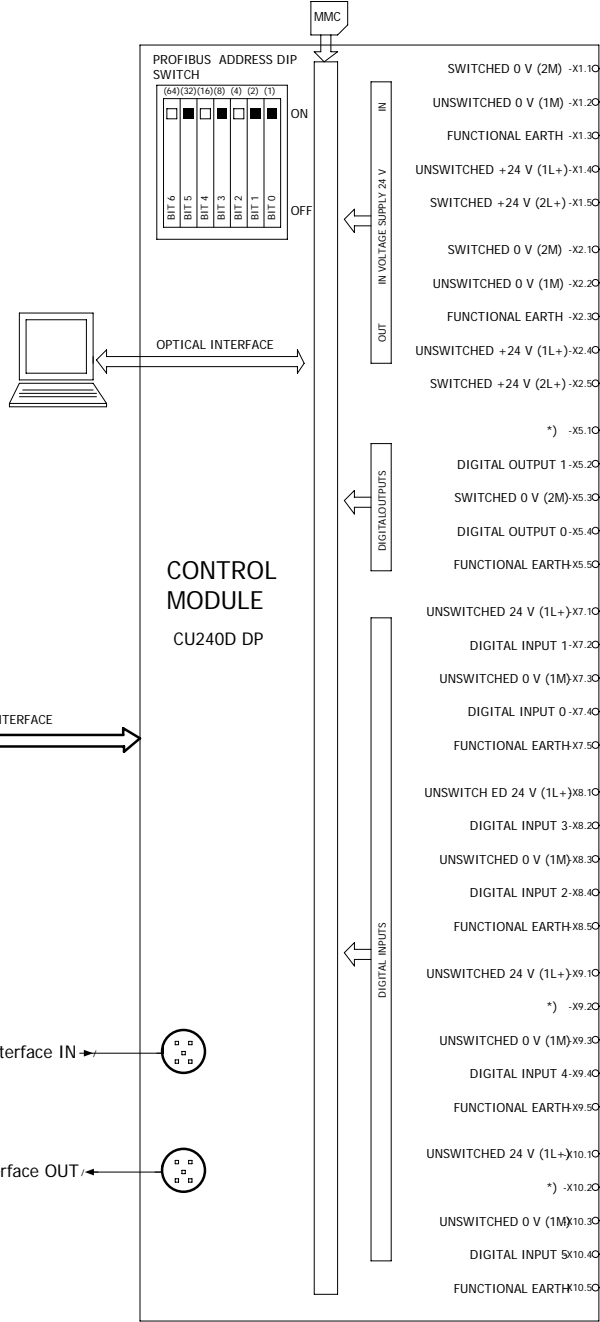
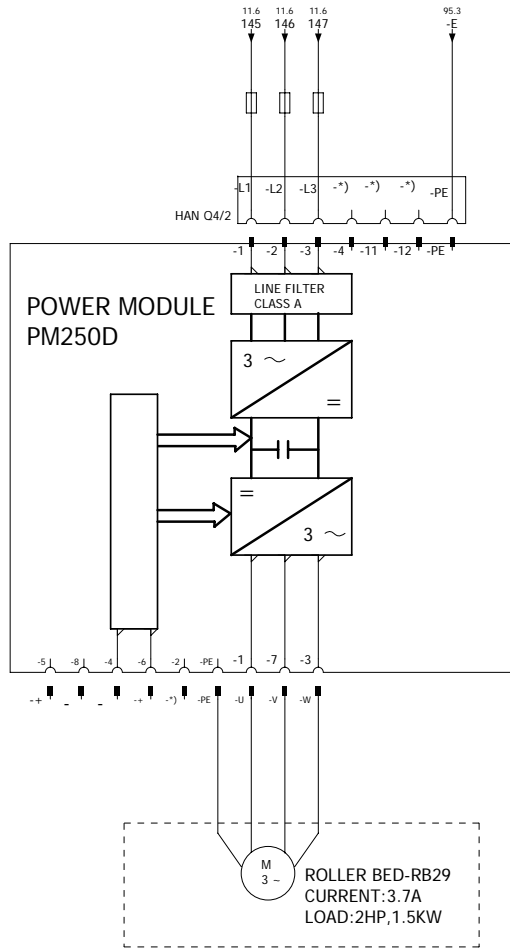

- SWITCHED 0 V (2M) -X1.10
- UNSWITCHED 0 V (1M) -X1.20
- FUNCTIONAL EARTH -X1.30
- UNSWITCHED +24 V (1L+) -X1.40
- SWITCHED +24 V (2L+) -X1.50
- SWITCHED 0 V (2M) -X2.10
- UNSWITCHED 0 V (1M) -X2.20
- FUNCTIONAL EARTH -X2.30
- UNSWITCHED +24 V (1L+) -X2.40
- SWITCHED +24 V (2L+) -X2.50
- *) -X5.10
- DIGITAL OUTPUT 1 -X5.20
- SWITCHED 0 V (2M) -X5.30
- DIGITAL OUTPUT 0 -X5.40
- FUNCTIONAL EARTH -X5.50
- UNSWITCHED 24 V (1L+) -X7.10
- DIGITAL INPUT 1 -X7.20
- UNSWITCHED 0 V (1M) -X7.30
- DIGITAL INPUT 0 -X7.40
- FUNCTIONAL EARTH -X7.50
- UNSWITCHED 24 V (1L+) -X8.10
- DIGITAL INPUT 3 -X8.20
- UNSWITCHED 0 V (1M) -X8.30
- DIGITAL INPUT 2 -X8.40
- FUNCTIONAL EARTH -X8.50
- UNSWITCHED 24 V (1L+) -X9.10
- *) -X9.20
- UNSWITCHED 0 V (1M) -X9.30
- DIGITAL INPUT 4 -X9.40
- FUNCTIONAL EARTH -X9.50
- UNSWITCHED 24 V (1L+) -X10.10
- *) -X10.20
- UNSWITCHED 0 V (1M) -X10.30
- DIGITAL INPUT 5 -X10.40
- FUNCTIONAL EARTH -X10.50

PX133:RB EXIT
PX134:RB FWD SLOW DN
PX135:RB ENTRY

DOCUMENT ID : CY/DD/R/07
REV : 00

| | | |
|----------|------|--------|
| Drawn | Date | Name |
| Checked | | SHITAL |
| Approved | | |

| | |
|---------------------|---------|
| PROJECT DESCRIPTION | TITLE |
| HA-382 VOLVO FRANCE | NODE-43 |

| | |
|-------------------|--------|
| PROJECT CODE :- | HA-382 |
| DRAWING NUMBER :- | |

NODE-44 RB30
ROLLER BED DRIVE

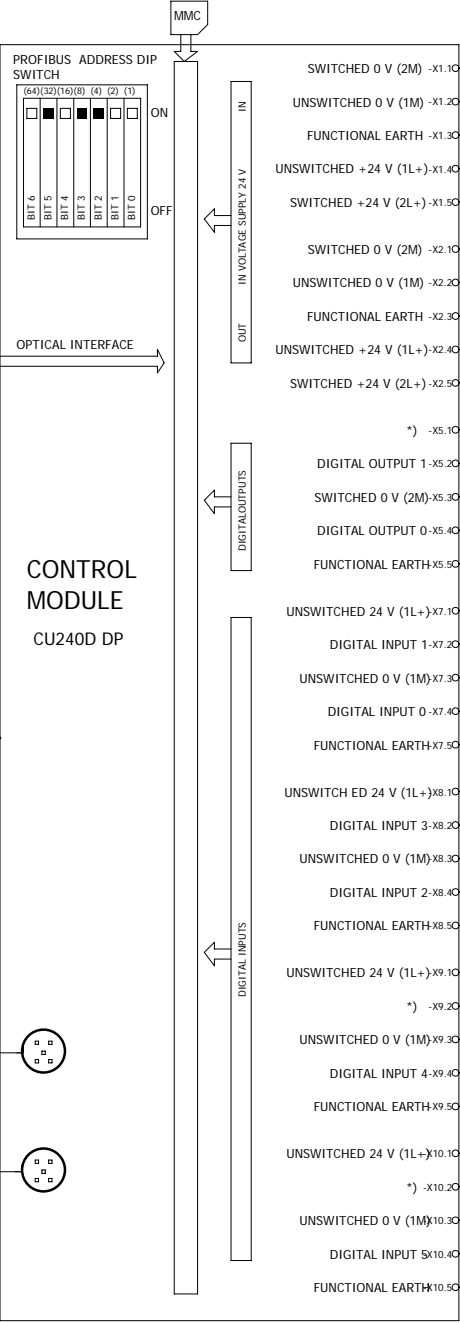
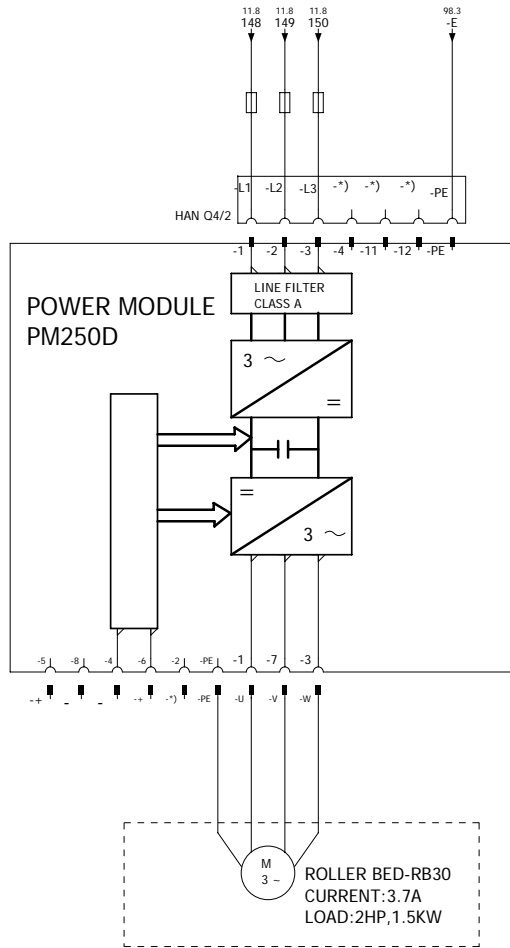

PROFIBUS DP interface IN FROM NODE-43

PROFIBUS DP interface OUT TO NODE-45

| | |
|----------|--------|
| DATE | NAME |
| CHECKED | SHITAL |
| APPROVED | |

| | |
|---------------------|---------|
| PROJECT DESCRIPTION | TITLE |
| HA-382 VOLVO FRANCE | NODE-44 |

| | |
|-------------------|--------|
| PROJECT CODE :- | HA-382 |
| DRAWING NUMBER :- | |

NODE-45 RB31
ROLLER BED DRIVE

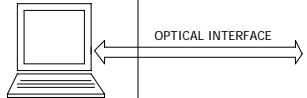
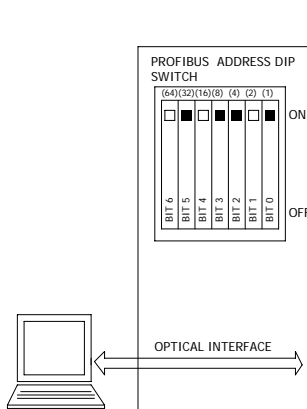
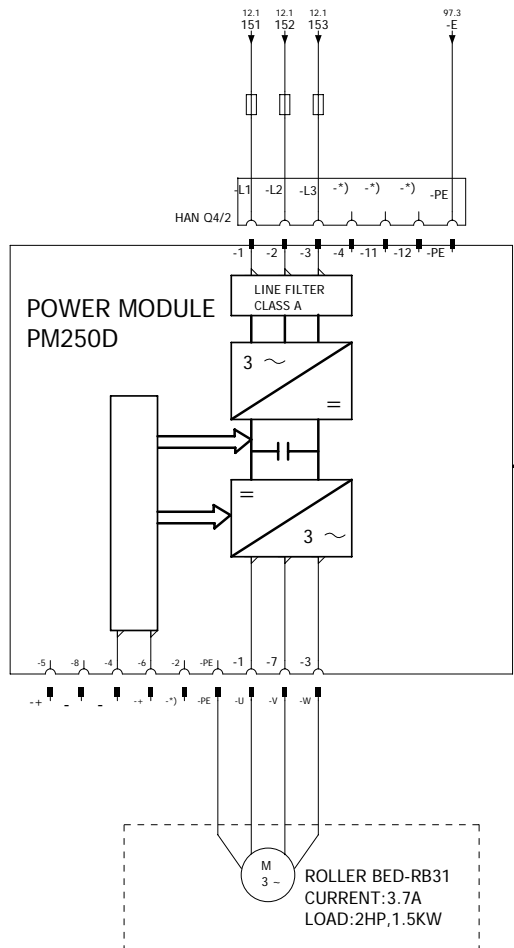

CONTROL MODULE
CU240D DP

PM-IF INTERFACE

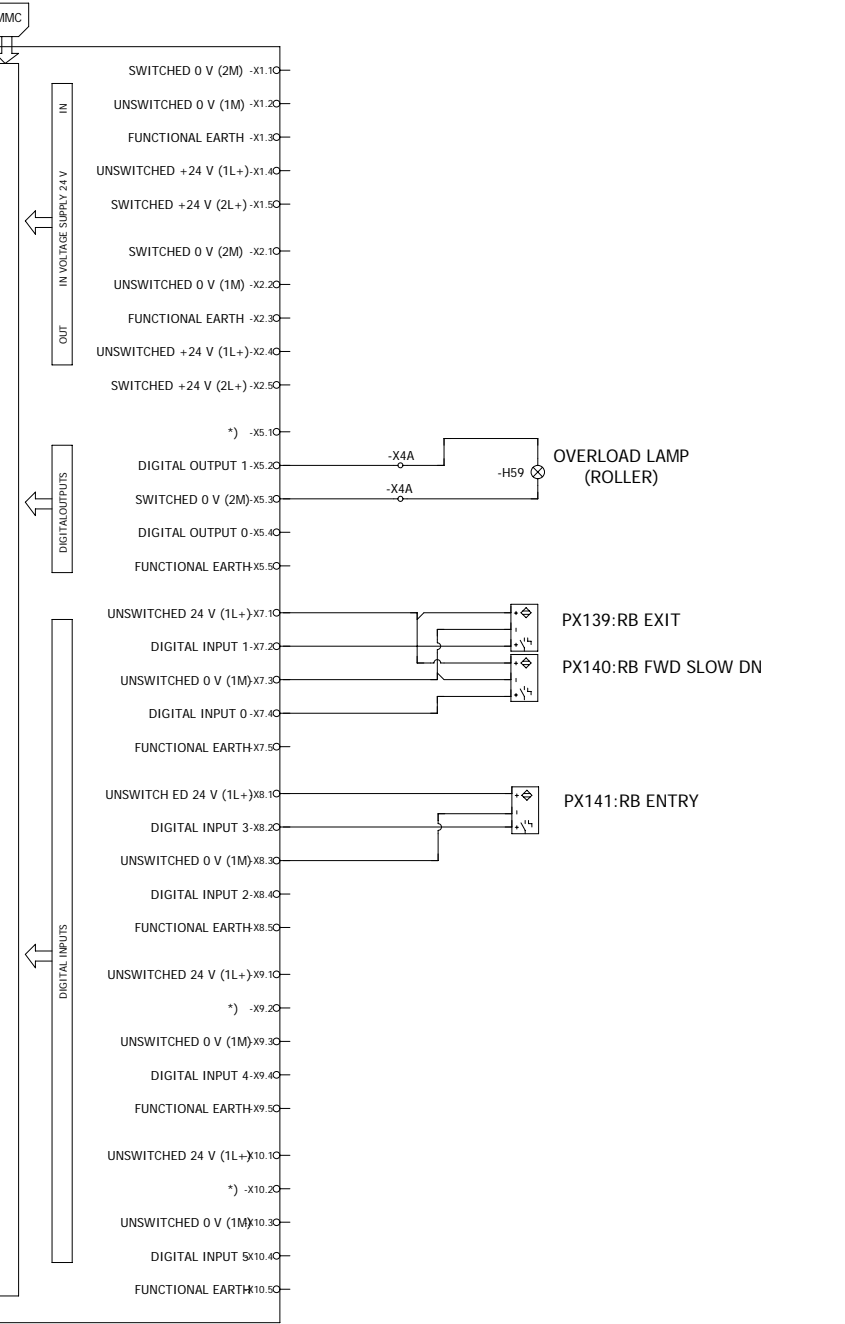
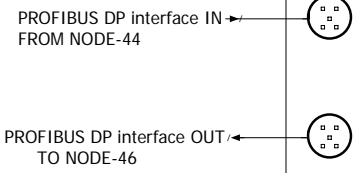

DOCUMENT ID : CY/DD/R/07

REV : 00

| | |
|----------|--------|
| DATE | NAME |
| | SHITAL |
| CHECKED | |
| APPROVED | |

NODE-46 RB32
ROLLER BED DRIVE

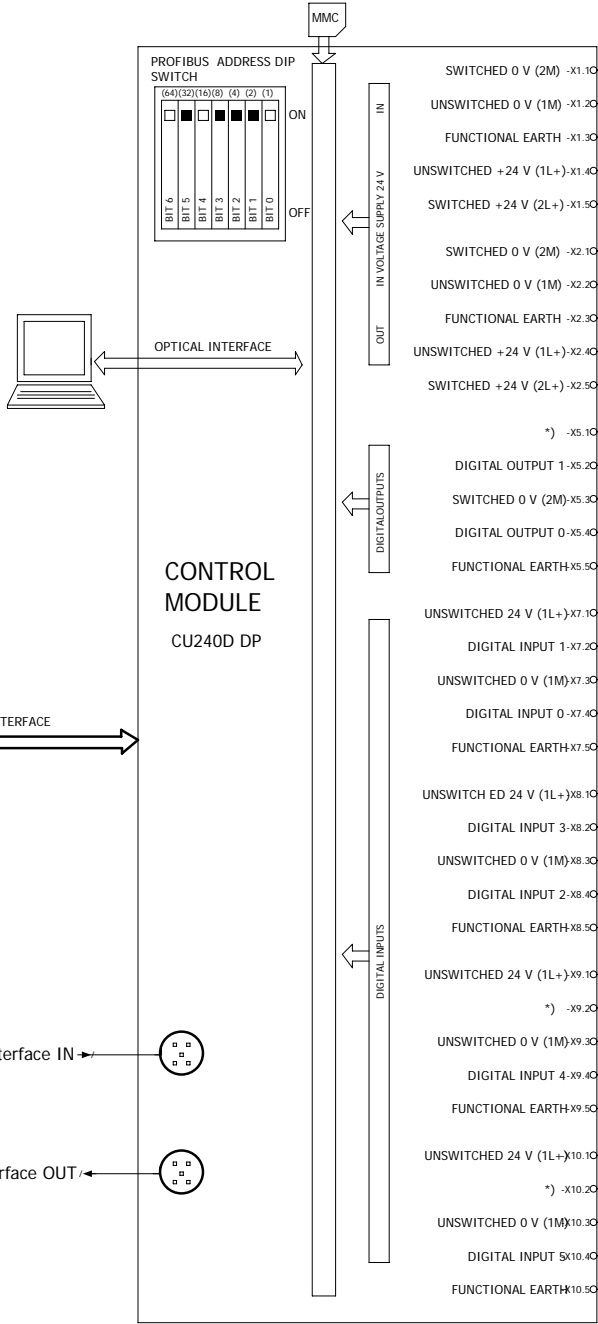
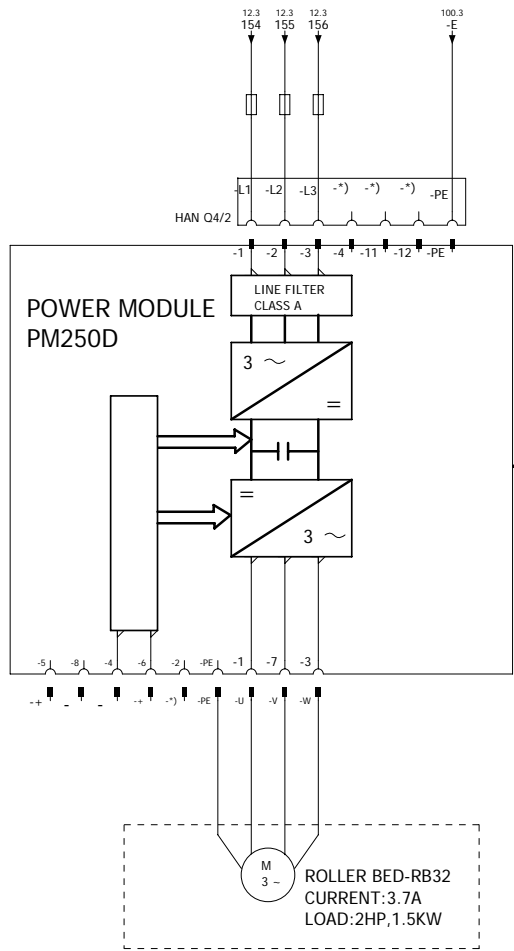

- SWITCHED 0 V (2M) -X1.10
- UNSWITCHED 0 V (1M) -X1.20
- FUNCTIONAL EARTH -X1.30
- UNSWITCHED +24 V (1L+) -X1.40
- SWITCHED +24 V (2L+) -X1.50
- SWITCHED 0 V (2M) -X2.10
- UNSWITCHED 0 V (1M) -X2.20
- FUNCTIONAL EARTH -X2.30
- UNSWITCHED +24 V (1L+) -X2.40
- SWITCHED +24 V (2L+) -X2.50
- *) -X5.10
- DIGITAL OUTPUT 1 -X5.20
- SWITCHED 0 V (2M) -X5.30
- DIGITAL OUTPUT 0 -X5.40
- FUNCTIONAL EARTH -X5.50
- UNSWITCHED 24 V (1L+) -X7.10
- DIGITAL INPUT 1 -X7.20
- UNSWITCHED 0 V (1M) -X7.30
- DIGITAL INPUT 0 -X7.40
- FUNCTIONAL EARTH -X7.50
- UNSWITCHED 24 V (1L+) -X8.10
- DIGITAL INPUT 3 -X8.20
- UNSWITCHED 0 V (1M) -X8.30
- DIGITAL INPUT 2 -X8.40
- FUNCTIONAL EARTH -X8.50
- UNSWITCHED 24 V (1L+) -X9.10
- *) -X9.20
- UNSWITCHED 0 V (1M) -X9.30
- DIGITAL INPUT 4 -X9.40
- FUNCTIONAL EARTH -X9.50
- UNSWITCHED 24 V (1L+) -X10.10
- *) -X10.20
- UNSWITCHED 0 V (1M) -X10.30
- DIGITAL INPUT 5 -X10.40
- FUNCTIONAL EARTH -X10.50

PX142:RB EXIT
PX143:RB FWD SLOW DN
PX144:RB ENTRY



| | Date | Name |
|----------|------|--------|
| DRAWN | | SHITAL |
| CHECKED | | |
| APPROVED | | |

| PROJECT DESCRIPTION | TITLE |
|---------------------|---------|
| HA-382 VOLVO FRANCE | NODE-46 |

| PROJECT CODE :- | DRAWING NUMBER :- |
|-----------------|-------------------|
| HA-382 | |

NODE-47 RB33
ROLLER BED DRIVE

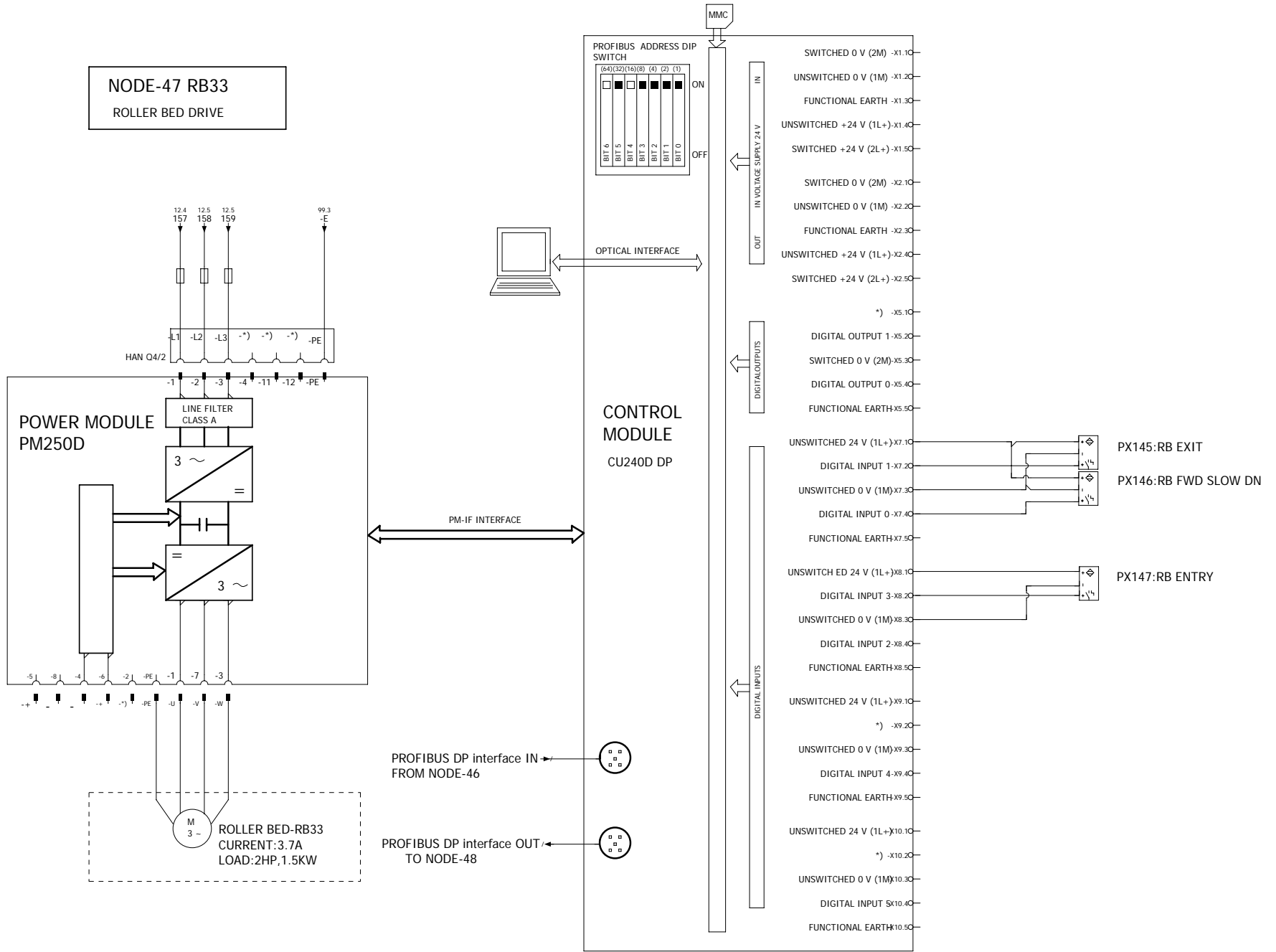

DOCUMENT ID : CY/DD/R/07
REV : 00

| | | |
|----------|------|--------|
| Drawn | Date | Name |
| Checked | | SHITAL |
| Approved | | |

NODE-48 RBTS03-A
ROLLER BED DRIVE

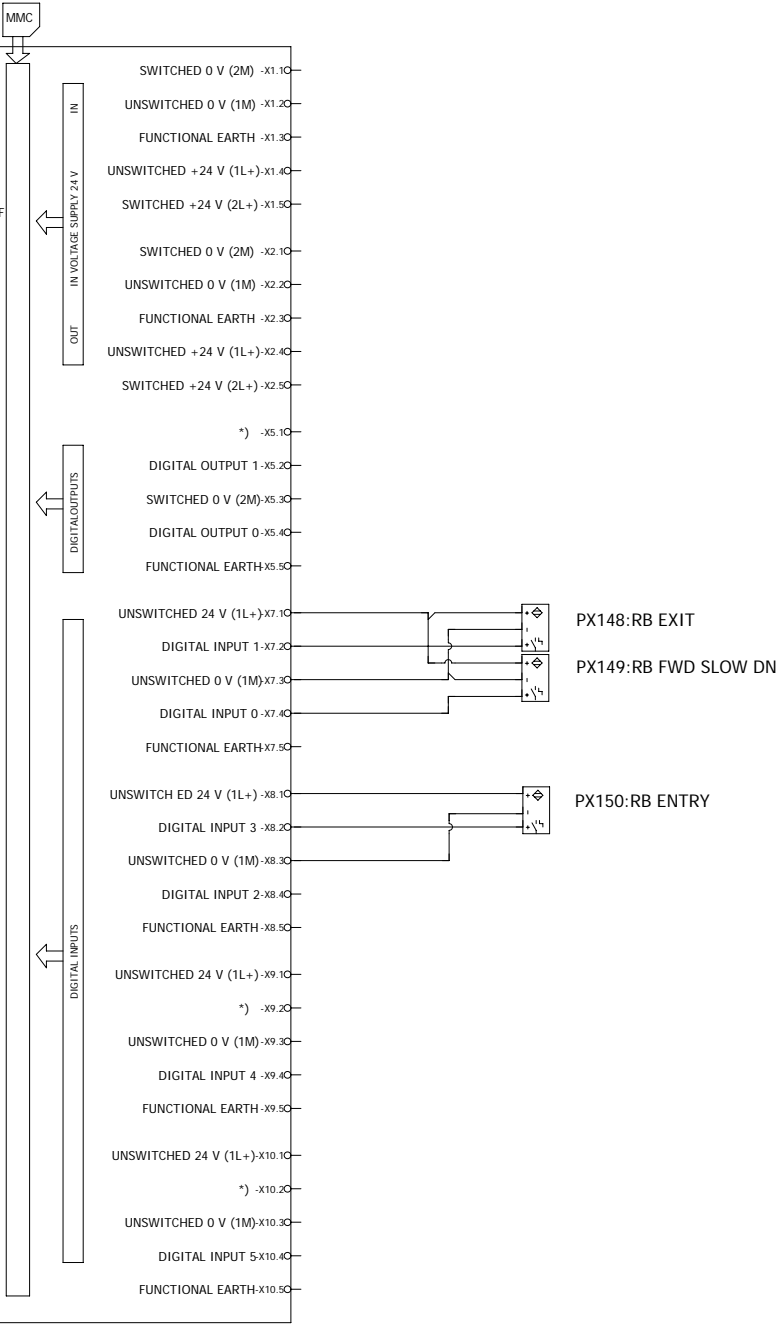
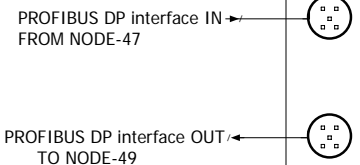
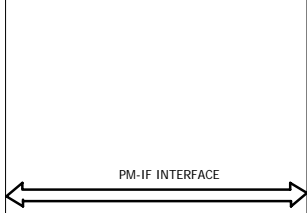
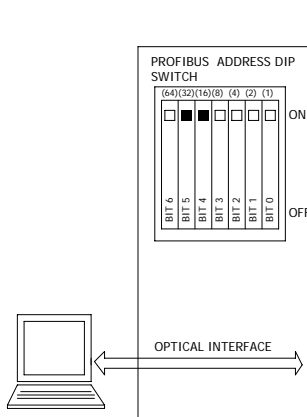
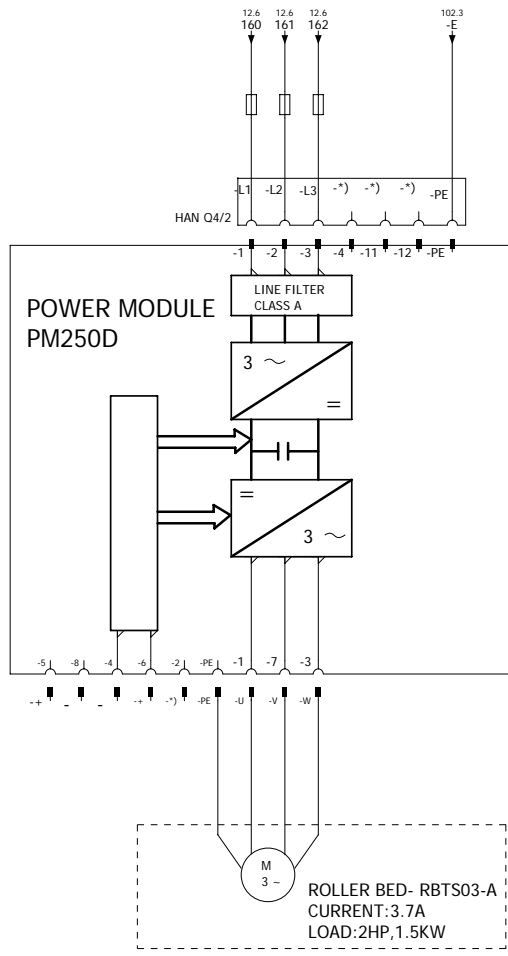

DOCUMENT ID : CY/DD/R/07

REV : 00

| | |
|----------|--------|
| DATE | NAME |
| | SHITAL |
| CHECKED | |
| APPROVED | |

| | |
|---------------------|---------|
| PROJECT DESCRIPTION | TITLE |
| HA-382 VOLVO FRANCE | NODE-48 |

| | |
|-------------------|--------|
| PROJECT CODE :- | HA-382 |
| DRAWING NUMBER :- | |

NODE-49 RBTS03-B
TRANSFER CAR DRIVE

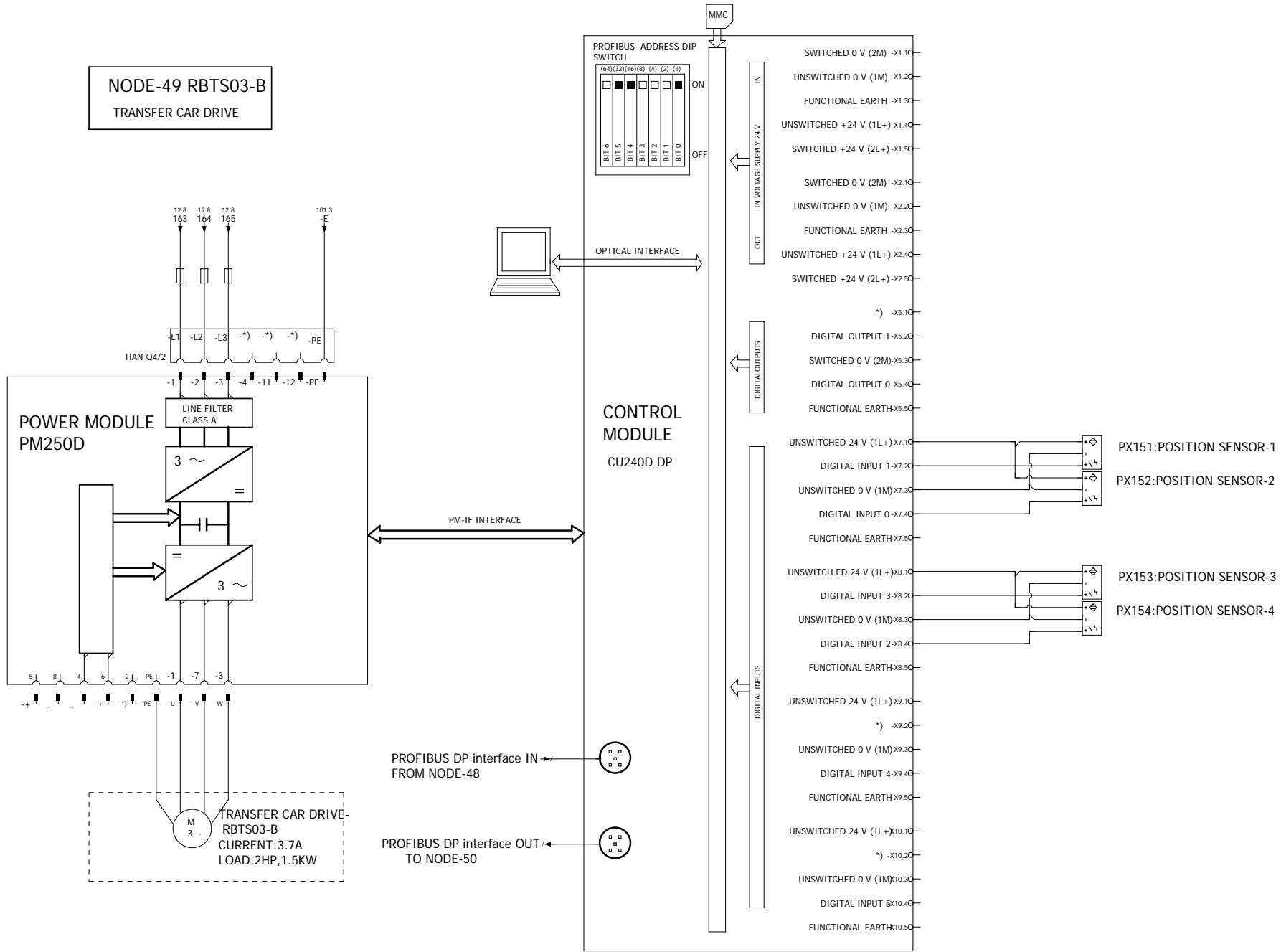

DOCUMENT ID : CY/DD/R/07
REV : 00



CYBERNETIK TECHNOLOGIES
PVT.LTD, PUNE

| | Date | Name |
|----------|------|--------|
| DRAWN | | SHITAL |
| CHECKED | | |
| APPROVED | | |

| PROJECT DESCRIPTION | TITLE |
|---------------------|---------|
| HA-382 VOLVO FRANCE | NODE-49 |

| PROJECT CODE :- | DRAWING NUMBER :- |
|-----------------|-------------------|
| HA-382 | |

| | |
|-------|-----|
| Page | 102 |
| Pages | 147 |

NODE-50 RBTS04-A
ROLLER BED DRIVE

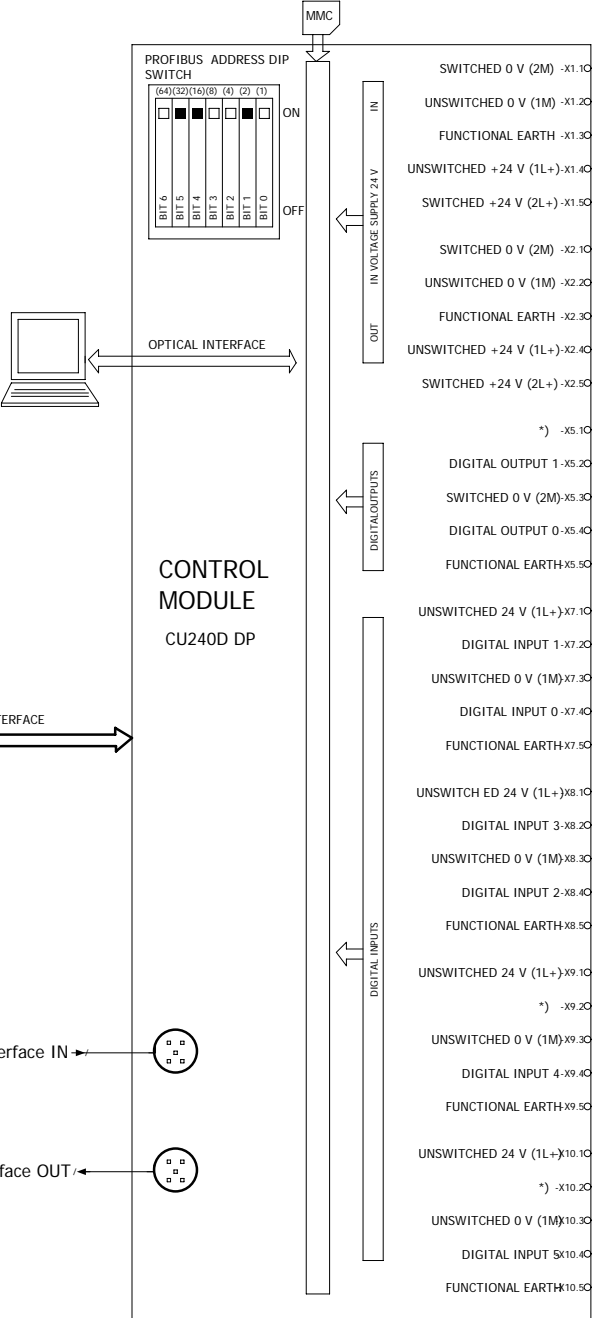
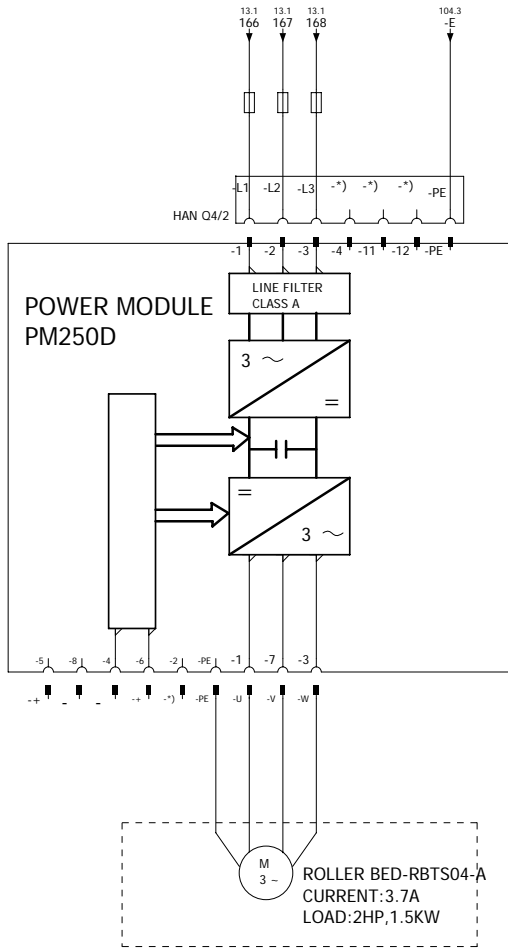

PROFIBUS DP interface IN FROM NODE-49

PROFIBUS DP interface OUT TO NODE-51



| | Date | Name |
|----------|------|--------|
| DRAWN | | SHITAL |
| CHECKED | | |
| APPROVED | | |

| PROJECT DESCRIPTION | TITLE |
|---------------------|---------|
| HA-382 VOLVO FRANCE | NODE-50 |

| PROJECT CODE :- | DRAWING NUMBER :- |
|-----------------|-------------------|
| HA-382 | |

| Page |
|-------|
| 103 |
| Pages |
| 147 |

NODE-51 RBTS04-B
TRANSFER CAR DRIVE

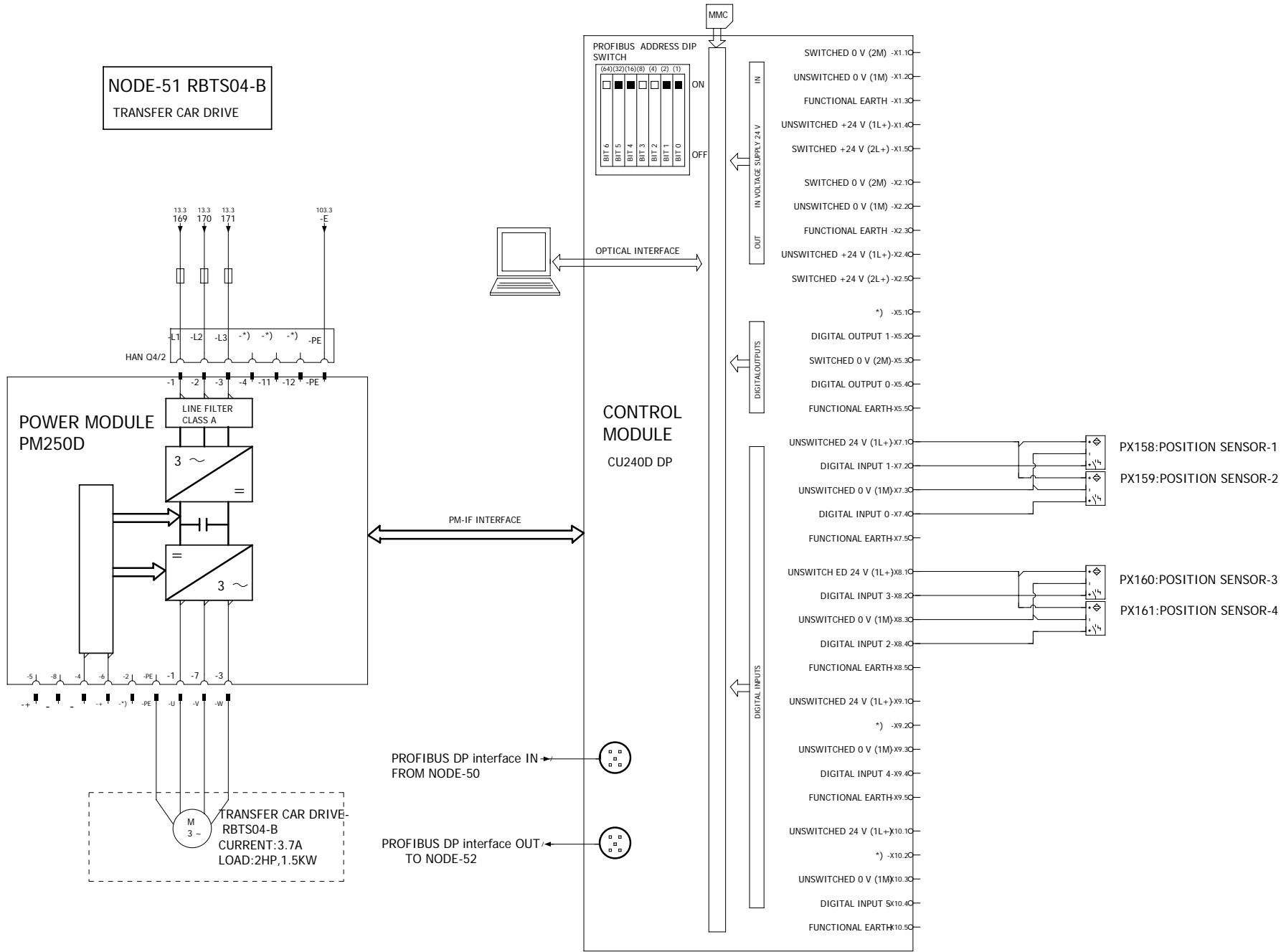

DOCUMENT ID : CY/DD/R/07
REV : 00

| | | |
|----------|------|--------|
| Drawn | Date | Name |
| Checked | | SHITAL |
| Approved | | |

NODE-52 RB34
ROLLER BED DRIVE

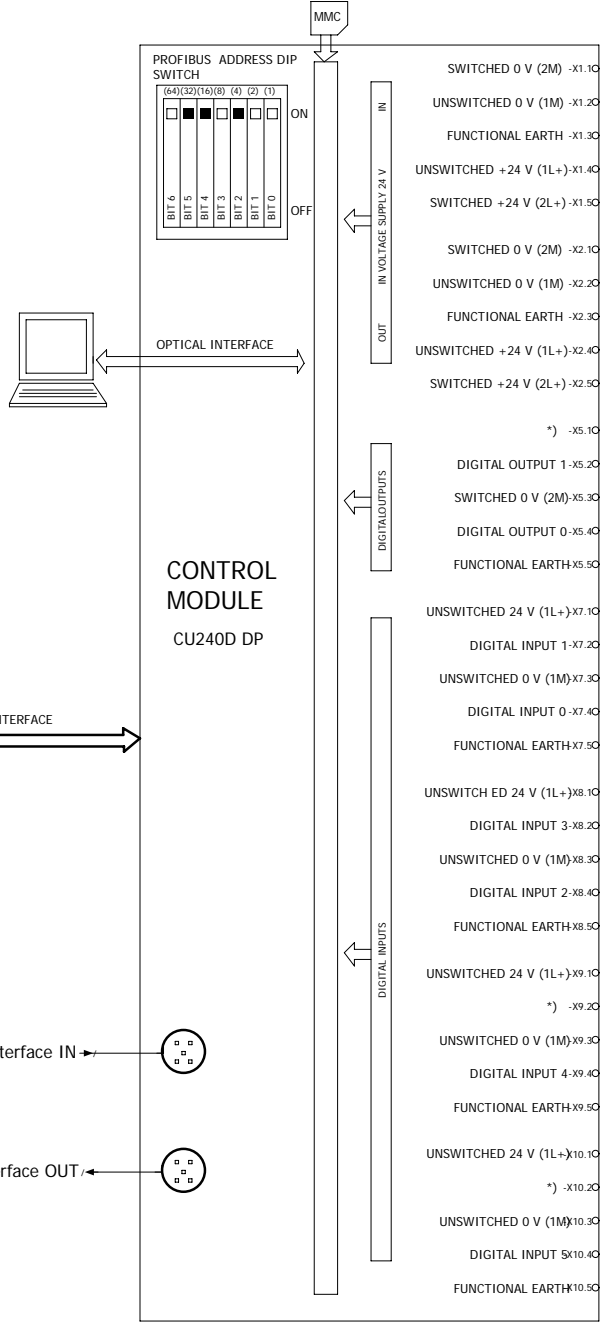
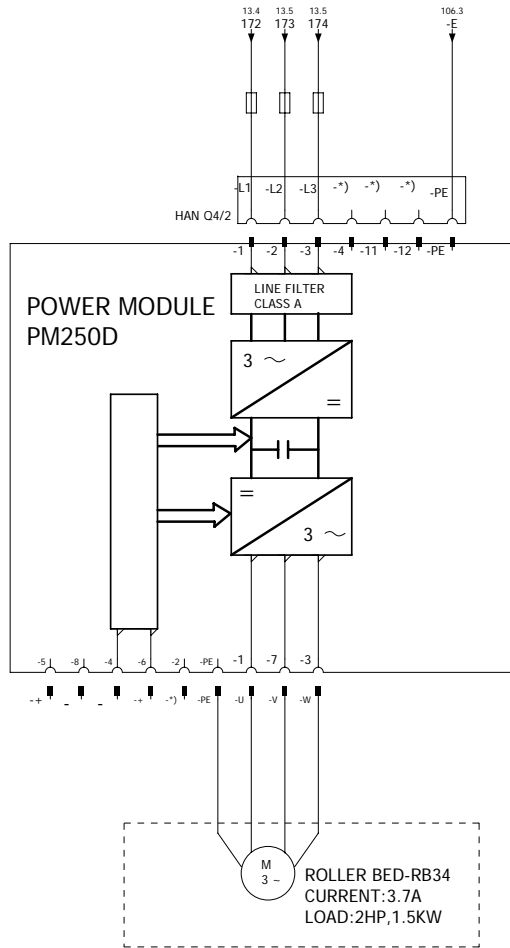

PROFIBUS DP interface IN FROM NODE-51

PROFIBUS DP interface OUT TO NODE-53

DOCUMENT ID : CY/DD/R/07
REV : 00



CYBERNETIK TECHNOLOGIES
PVT.LTD, PUNE

| | Date | Name |
|----------|------|--------|
| DRAWN | | SHITAL |
| CHECKED | | |
| APPROVED | | |

| PROJECT DESCRIPTION | TITLE |
|---------------------|---------|
| HA-382 VOLVO FRANCE | NODE-52 |

| PROJECT CODE :- | DRAWING NUMBER :- |
|-----------------|-------------------|
| HA-382 | |

| | |
|-------|-----|
| Page | 105 |
| Pages | 147 |

NODE-53 RB35
ROLLER BED DRIVE

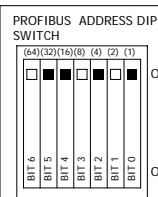
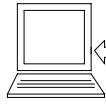
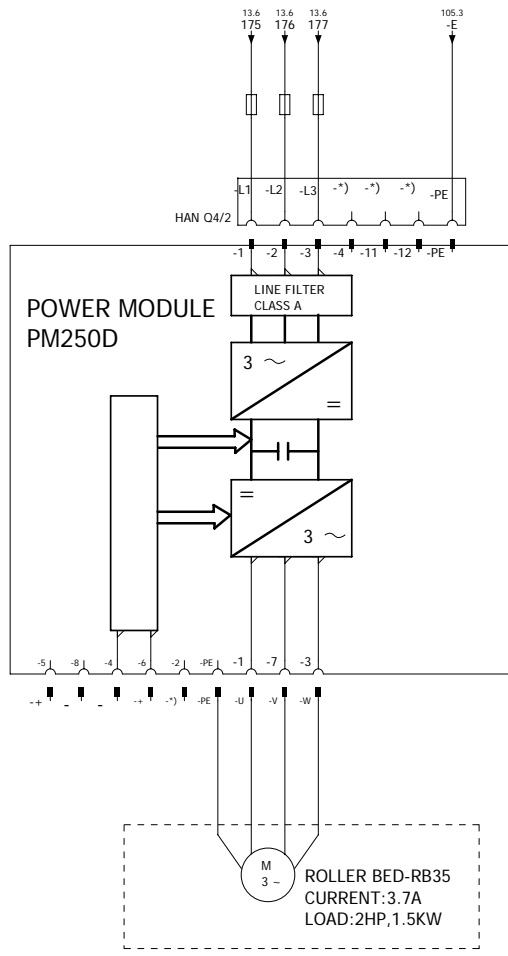

CONTROL MODULE
CU240D DP

PM-IF INTERFACE

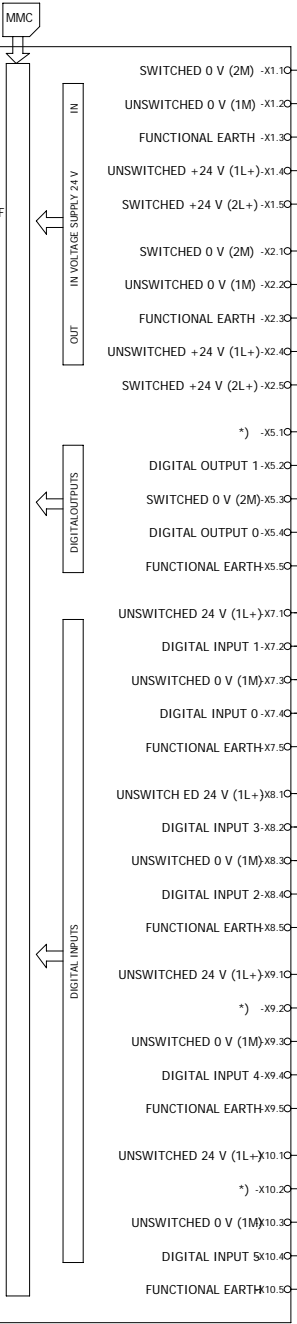
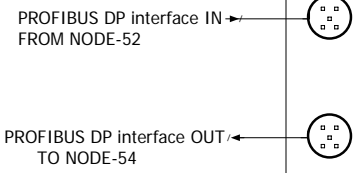

DOCUMENT ID : CY/DD/R/07

REV : 00



CYBERNETIK TECHNOLOGIES
PVT.LTD, PUNE

| | Date | Name |
|----------|------|--------|
| DRAWN | | SHITAL |
| CHECKED | | |
| APPROVED | | |

| PROJECT DESCRIPTION | TITLE |
|---------------------|---------|
| HA-382 VOLVO FRANCE | NODE-53 |

| PROJECT CODE :- | DRAWING NUMBER :- |
|-----------------|-------------------|
| HA-382 | |

| Page | Pages |
|------|-------|
| 106 | 147 |

NODE-54 RB36
ROLLER BED DRIVE

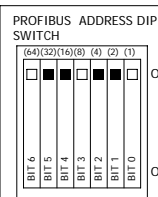
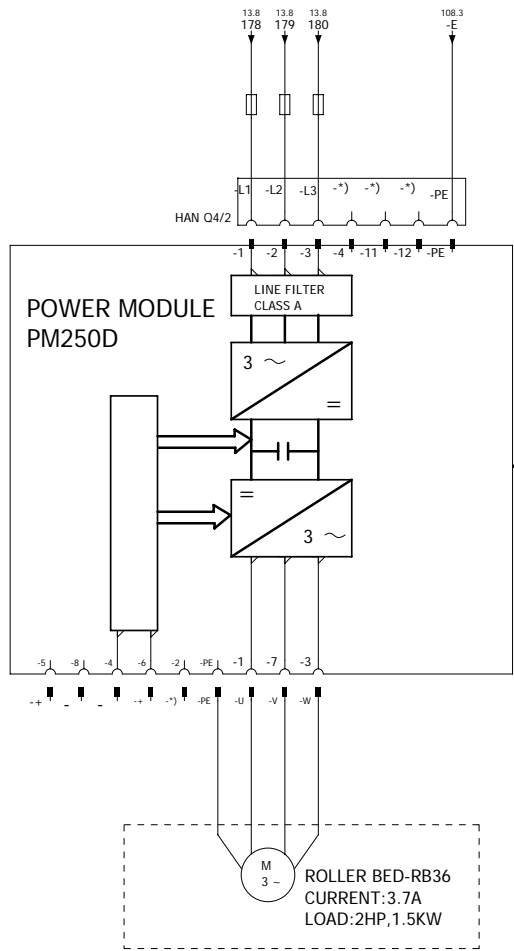

OPTICAL INTERFACE

CONTROL MODULE
CU240D DP

PM-IF INTERFACE

PROFIBUS DP interface IN FROM NODE-53

PROFIBUS DP interface OUT TO NODE-55

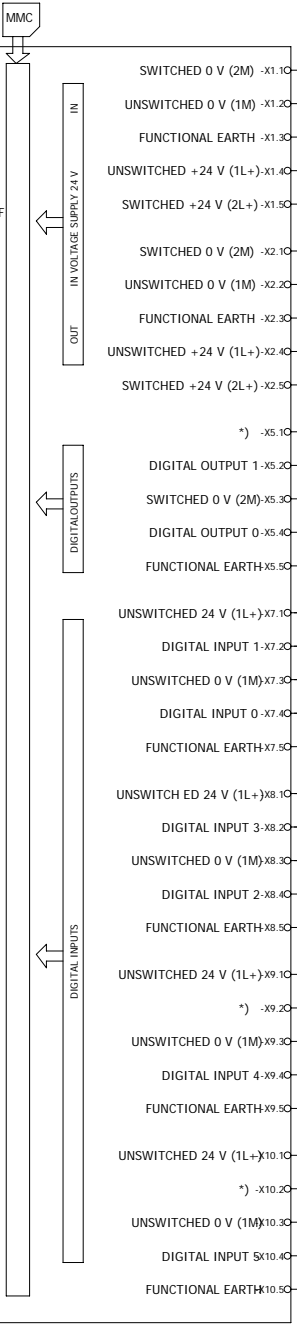

| | Date | Name |
|----------|------|--------|
| DRAWN | | SHITAL |
| CHECKED | | |
| APPROVED | | |

| PROJECT DESCRIPTION | TITLE |
|---------------------|---------|
| HA-382 VOLVO FRANCE | NODE-54 |

| PROJECT CODE :- | DRAWING NUMBER :- |
|-----------------|-------------------|
| HA-382 | |

NODE-55 RB37
ROLLER BED DRIVE

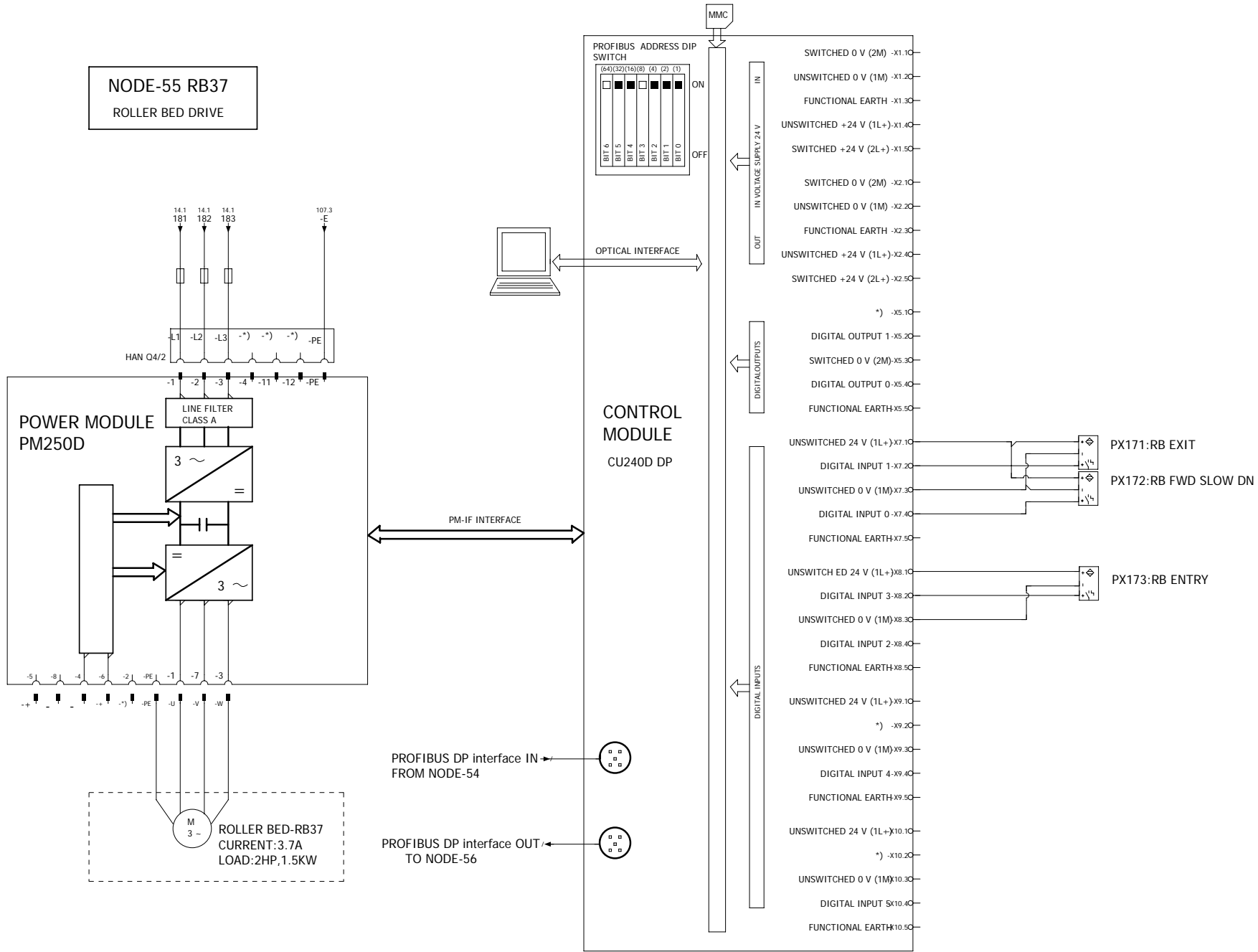

DOCUMENT ID : CY/DD/R/07

REV : 00

CYBERNETIK TECHNOLOGIES
PVT.LTD, PUNE

| Drawn | Date | Name |
|----------|------|--------|
| CHECKED | | SHITAL |
| APPROVED | | |

PROJECT DESCRIPTION
HA-382 VOLVO FRANCE

TITLE
NODE-55

PROJECT CODE :- **HA-382**
DRAWING NUMBER :-
Page 108
Pages 147

NODE-56 RB38
ROLLER BED DRIVE

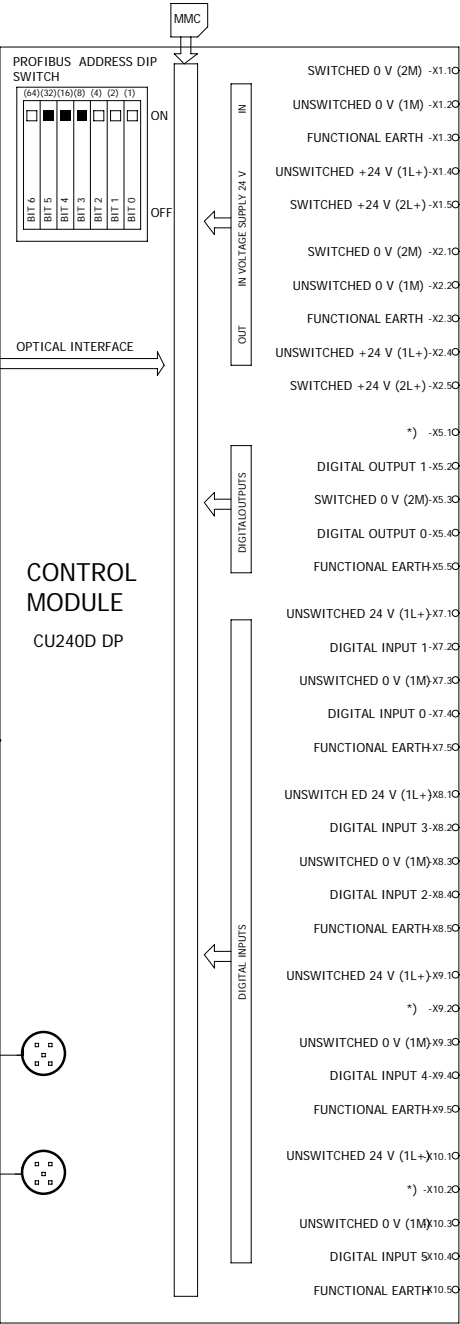
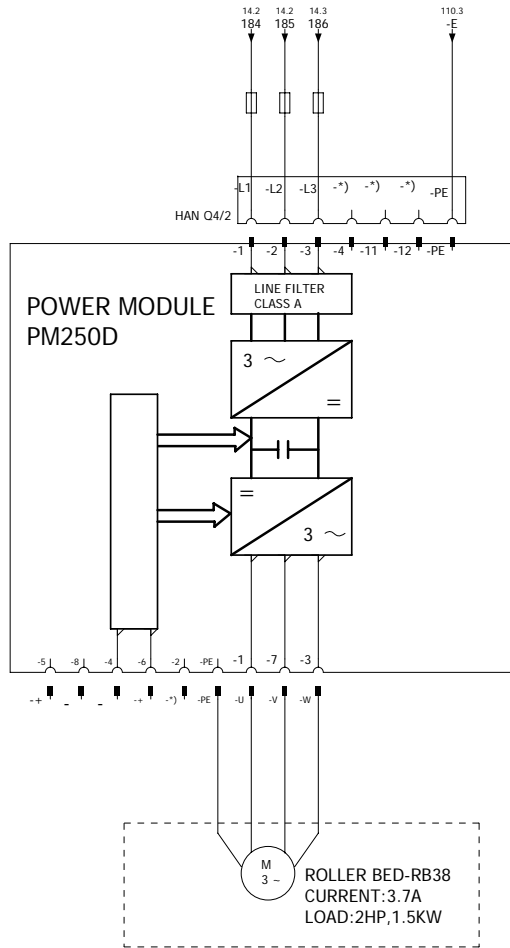

PM-IF INTERFACE

PROFIBUS DP interface IN FROM NODE-55

PROFIBUS DP interface OUT TO NODE57-

- SWITCHED 0 V (2M) -X1.10
- UNSWITCHED 0 V (1M) -X1.20
- FUNCTIONAL EARTH -X1.30
- UNSWITCHED +24 V (1L+) -X1.40
- SWITCHED +24 V (2L+) -X1.50
- SWITCHED 0 V (2M) -X2.10
- UNSWITCHED 0 V (1M) -X2.20
- FUNCTIONAL EARTH -X2.30
- UNSWITCHED +24 V (1L+) -X2.40
- SWITCHED +24 V (2L+) -X2.50
- *) -X5.10
- DIGITAL OUTPUT 1 -X5.20
- SWITCHED 0 V (2M) -X5.30
- DIGITAL OUTPUT 0 -X5.40
- FUNCTIONAL EARTH -X5.50
- UNSWITCHED 24 V (1L+) -X7.10
- DIGITAL INPUT 1 -X7.20
- UNSWITCHED 0 V (1M) -X7.30
- DIGITAL INPUT 0 -X7.40
- FUNCTIONAL EARTH -X7.50
- UNSWITCHED 24 V (1L+) -X8.10
- DIGITAL INPUT 3 -X8.20
- UNSWITCHED 0 V (1M) -X8.30
- DIGITAL INPUT 2 -X8.40
- FUNCTIONAL EARTH -X8.50
- UNSWITCHED 24 V (1L+) -X9.10
- *) -X9.20
- UNSWITCHED 0 V (1M) -X9.30
- DIGITAL INPUT 4 -X9.40
- FUNCTIONAL EARTH -X9.50
- UNSWITCHED 24 V (1L+) -X10.10
- *) -X10.20
- UNSWITCHED 0 V (1M) -X10.30
- DIGITAL INPUT 5 -X10.40
- FUNCTIONAL EARTH -X10.50

PX174:RB EXIT
PX175:RB FWD SLOW DN

PX176:RB ENTRY

DOCUMENT ID : CY/DD/R/07
REV : 00

| | | |
|----------|------|--------|
| Drawn | Date | Name |
| Checked | | SHITAL |
| Approved | | |

| | |
|---------------------|---------|
| PROJECT DESCRIPTION | TITLE |
| HA-382 VOLVO FRANCE | NODE-56 |

| | |
|-------------------|--------|
| PROJECT CODE :- | HA-382 |
| DRAWING NUMBER :- | |

NODE-57 RB39
ROLLER BED DRIVE

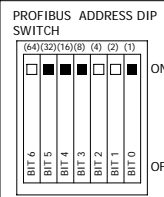
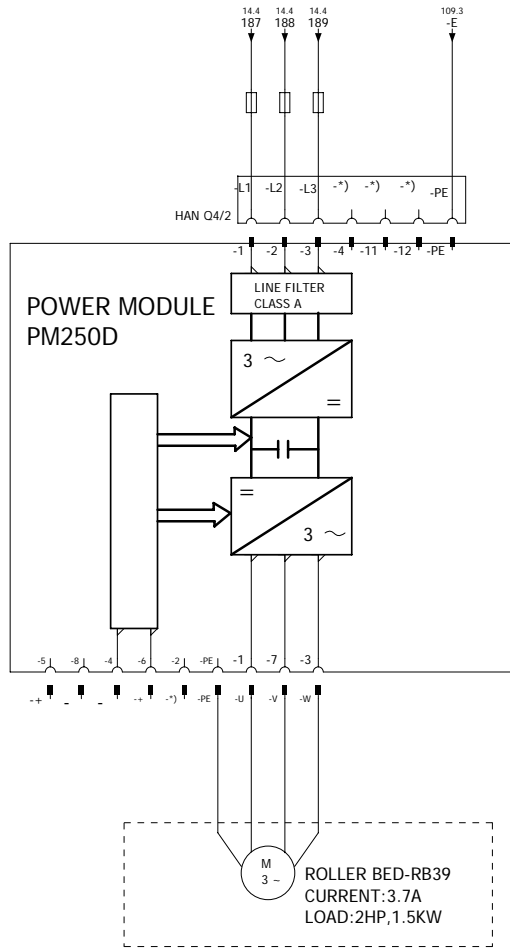

CONTROL MODULE
CU240D DP

PM-IF INTERFACE

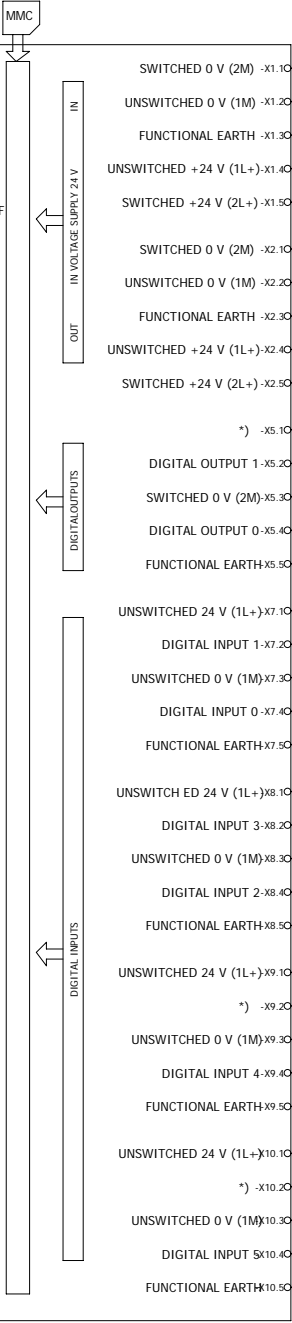
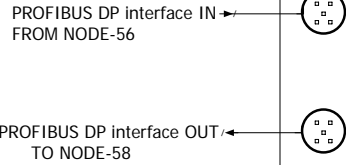

| | |
|----------|--------|
| DATE | NAME |
| CHECKED | SHITAL |
| APPROVED | |

| | |
|---------------------|---------|
| PROJECT DESCRIPTION | TITLE |
| HA-382 VOLVO FRANCE | NODE-57 |

| | |
|-------------------|--------|
| PROJECT CODE :- | HA-382 |
| DRAWING NUMBER :- | |

NODE-58 RBSL05-A
ROLLER BED

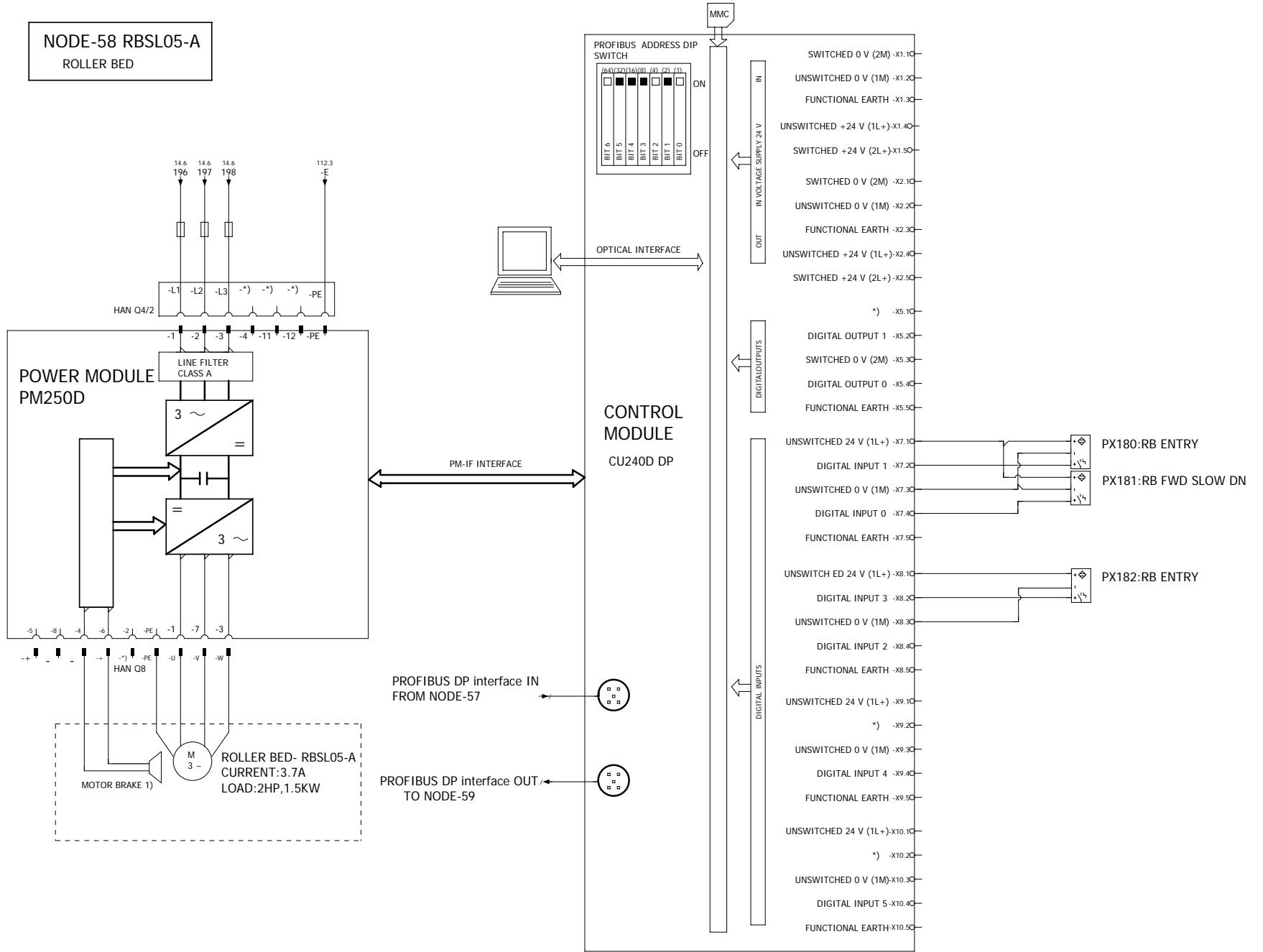

DOCUMENT ID : CY/DD/R/07
REV : 00

| | | |
|----------|------|--------|
| Drawn | Date | Name |
| Checked | | SHITAL |
| Approved | | |

| | |
|----------------------------|--------------|
| PROJECT DESCRIPTION | TITLE |
| HA-382 VOLVO FRANCE | NODE-58 |

| | |
|--------------------------|---------------|
| PROJECT CODE :- | HA-382 |
| DRAWING NUMBER :- | |

NODE-59 RBSL05-B
LIFT MOTOR DRIVE

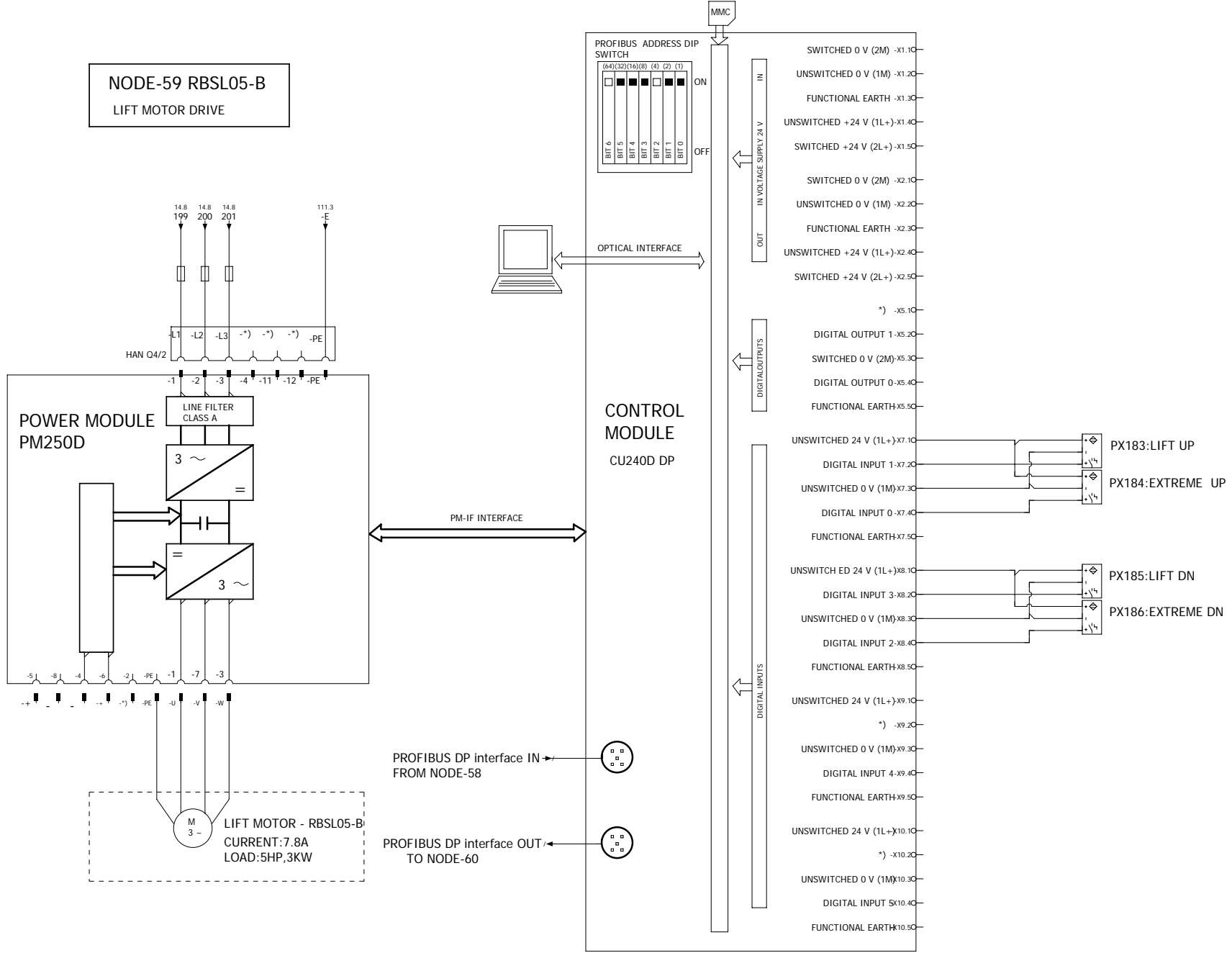

DOCUMENT ID : CY/DD/R/07
REV : 00

CYBERNETIK TECHNOLOGIES
PVT.LTD, PUNE

| | | |
|----------|------|--------|
| Drawn | Date | Name |
| Checked | | SHITAL |
| Approved | | |

PROJECT DESCRIPTION
HA-382 VOLVO FRANCE

TITLE
NODE-59

PROJECT CODE :- HA-382
DRAWING NUMBER :-

NODE-60 RBSL06-A
ROLLER BED

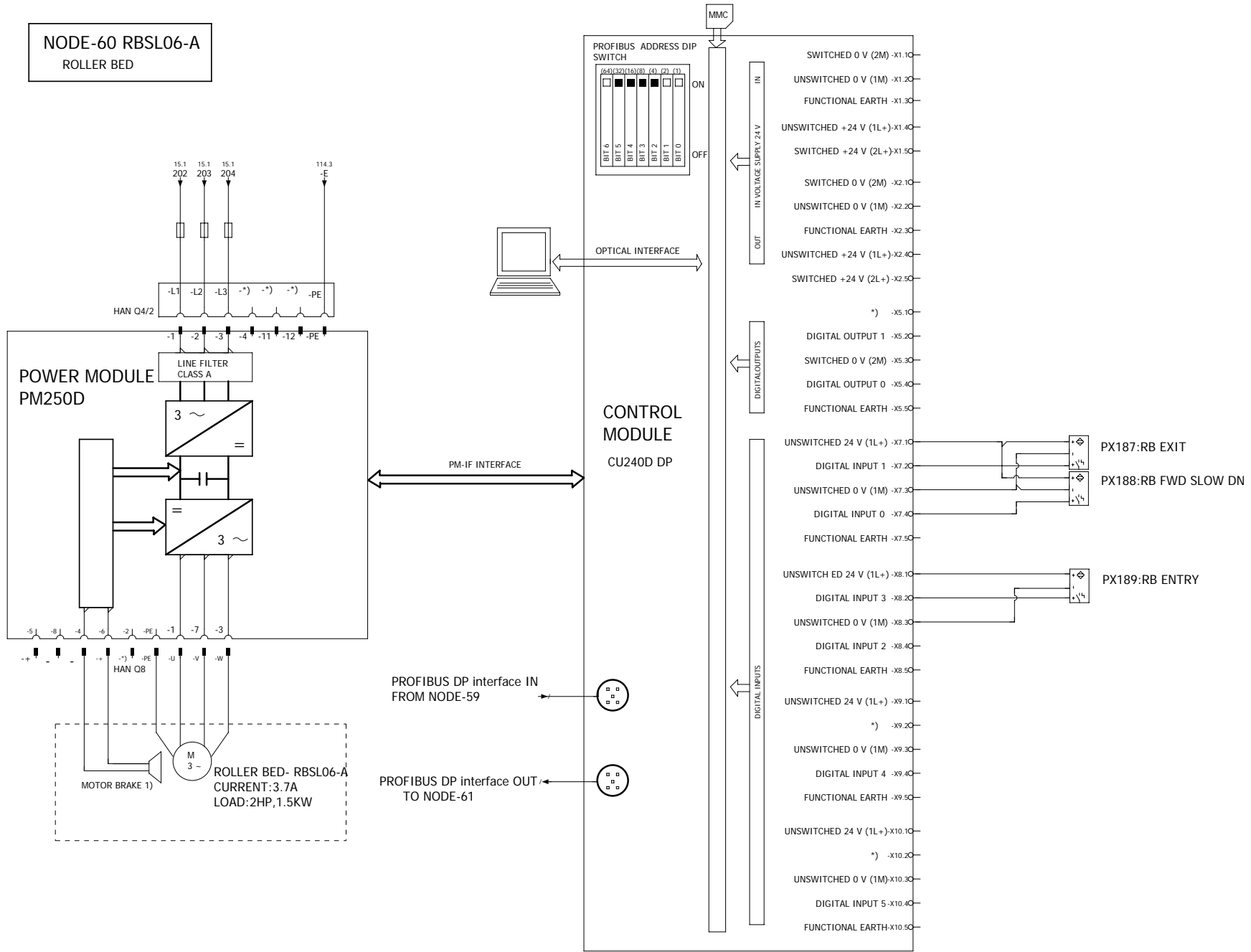

DOCUMENT ID : CY/DD/R/07
REV : 00



CYBERNETIK TECHNOLOGIES
PVT.LTD, PUNE

| | | |
|----------|------|--------|
| Drawn | Date | Name |
| Checked | | SHITAL |
| Approved | | |

| | |
|---------------------|---------|
| PROJECT DESCRIPTION | TITLE |
| HA-382 VOLVO FRANCE | NODE-60 |

| | |
|-------------------|--------|
| PROJECT CODE :- | HA-382 |
| DRAWING NUMBER :- | |

| | |
|-------|-----|
| Page | 113 |
| Pages | 147 |

NODE-61 RBSL06-B
LIFT DRIVE

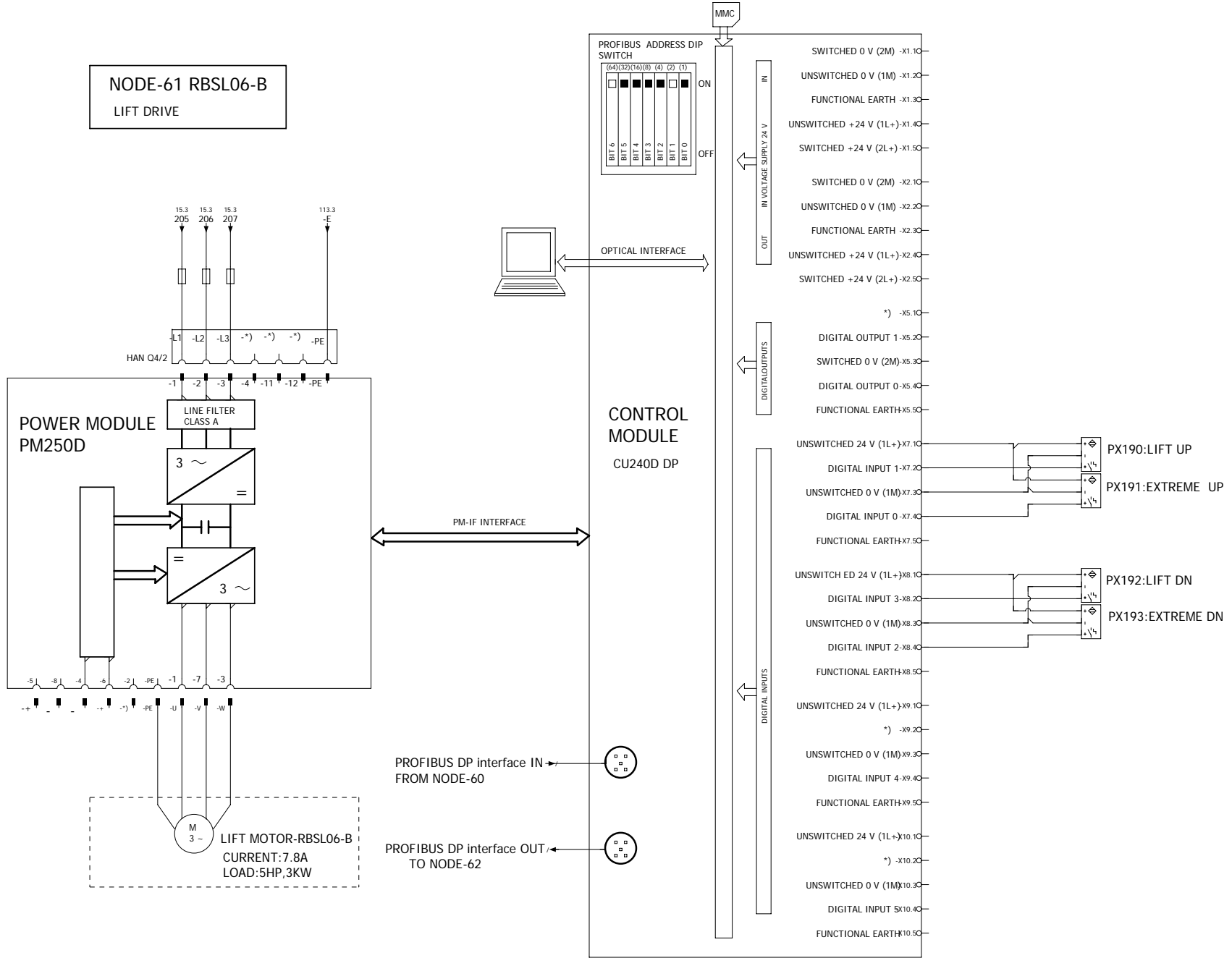

DOCUMENT ID : CY/DD/R/07
REV : 00

| | | |
|----------|------|--------|
| Drawn | Date | Name |
| Checked | | SHITAL |
| Approved | | |

| | |
|---------------------|---------|
| PROJECT DESCRIPTION | TITLE |
| HA-382 VOLVO FRANCE | NODE-61 |

| | |
|-------------------|--------|
| PROJECT CODE :- | HA-382 |
| DRAWING NUMBER :- | |

NODE-62 RBSL07-A
ROLLER BED DRIVE

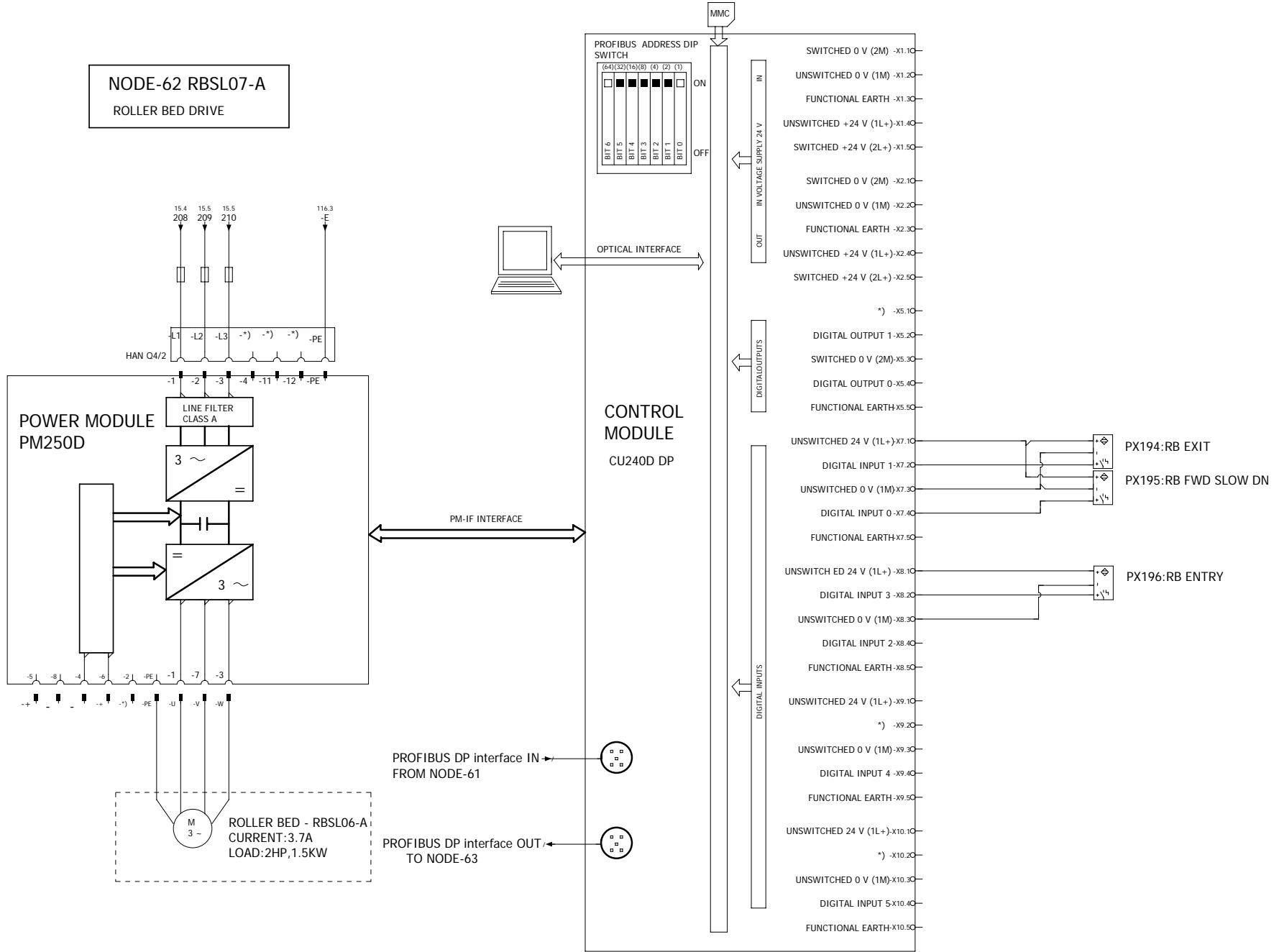

DOCUMENT ID : CY/DD/R/07
REV : 00

NODE-63 RBSL07-B
LIFT MOTOR DRIVE

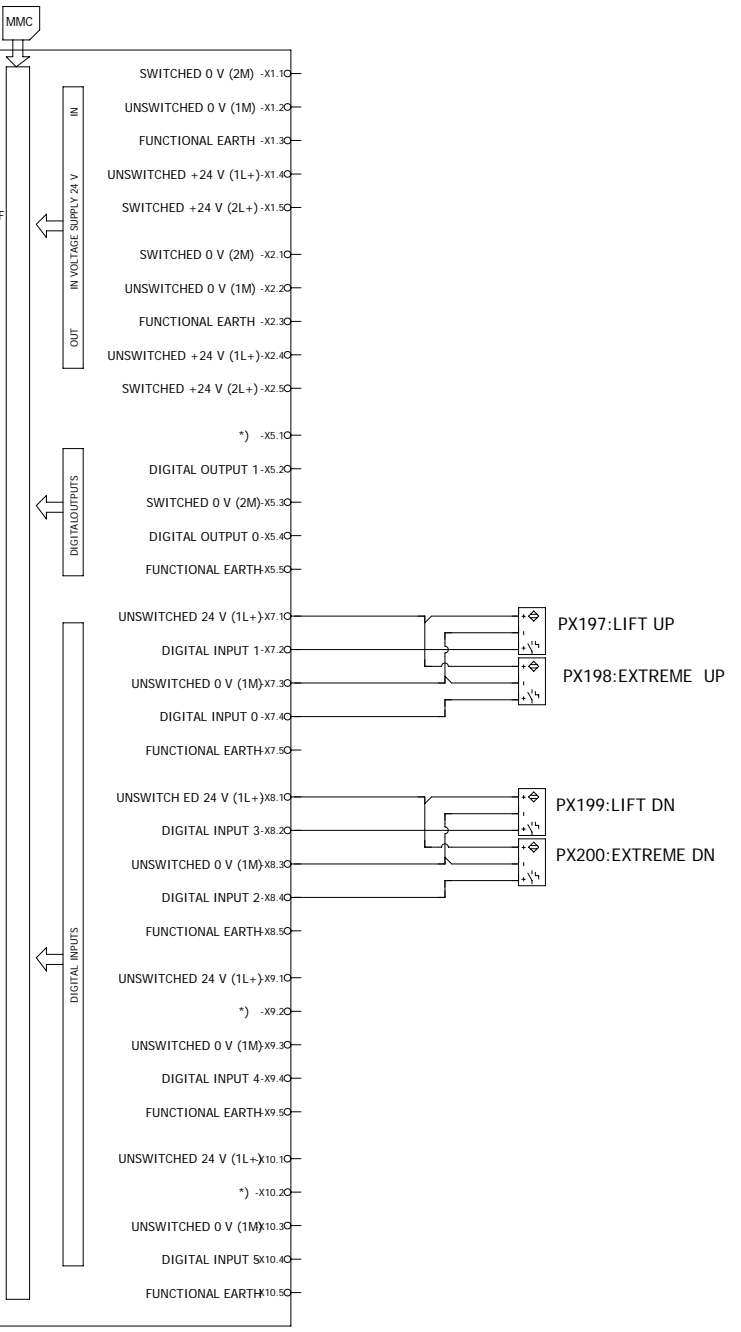
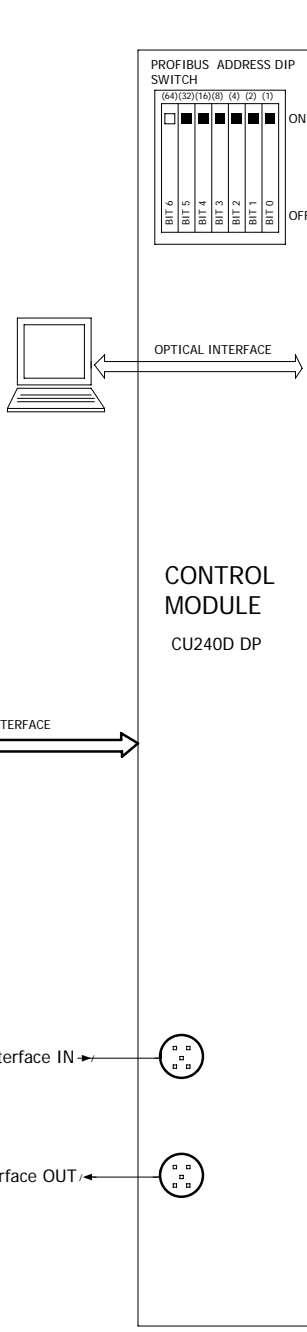
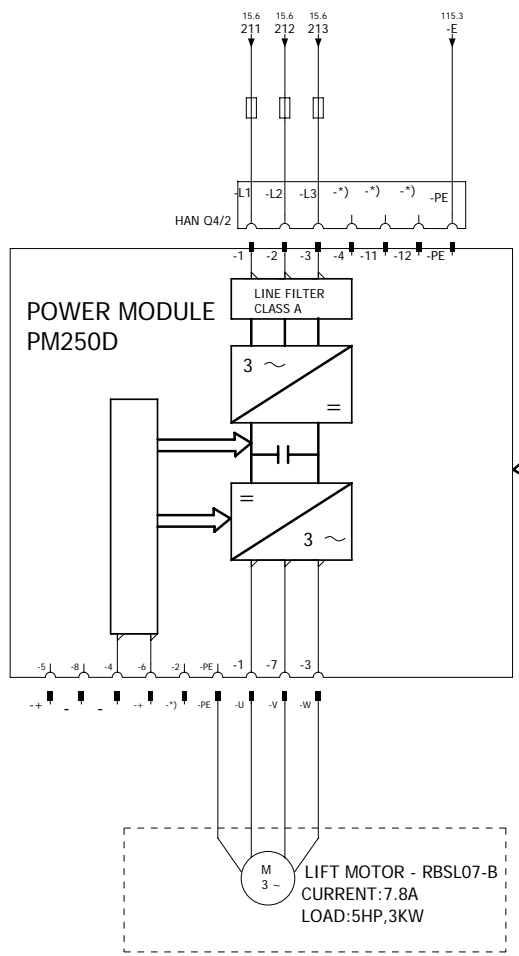

DOCUMENT ID : CY/DD/R/07
REV : 00

CYBERNETIK TECHNOLOGIES PVT.LTD, PUNE

| | | |
|----------|------|--------|
| Drawn | Date | Name |
| Checked | | SHITAL |
| Approved | | |

PROJECT DESCRIPTION
HA-382 VOLVO FRANCE

TITLE
NODE-63

PROJECT CODE :- HA-382
DRAWING NUMBER :-

NODE-64 RBTS05-A
ROLLER BED

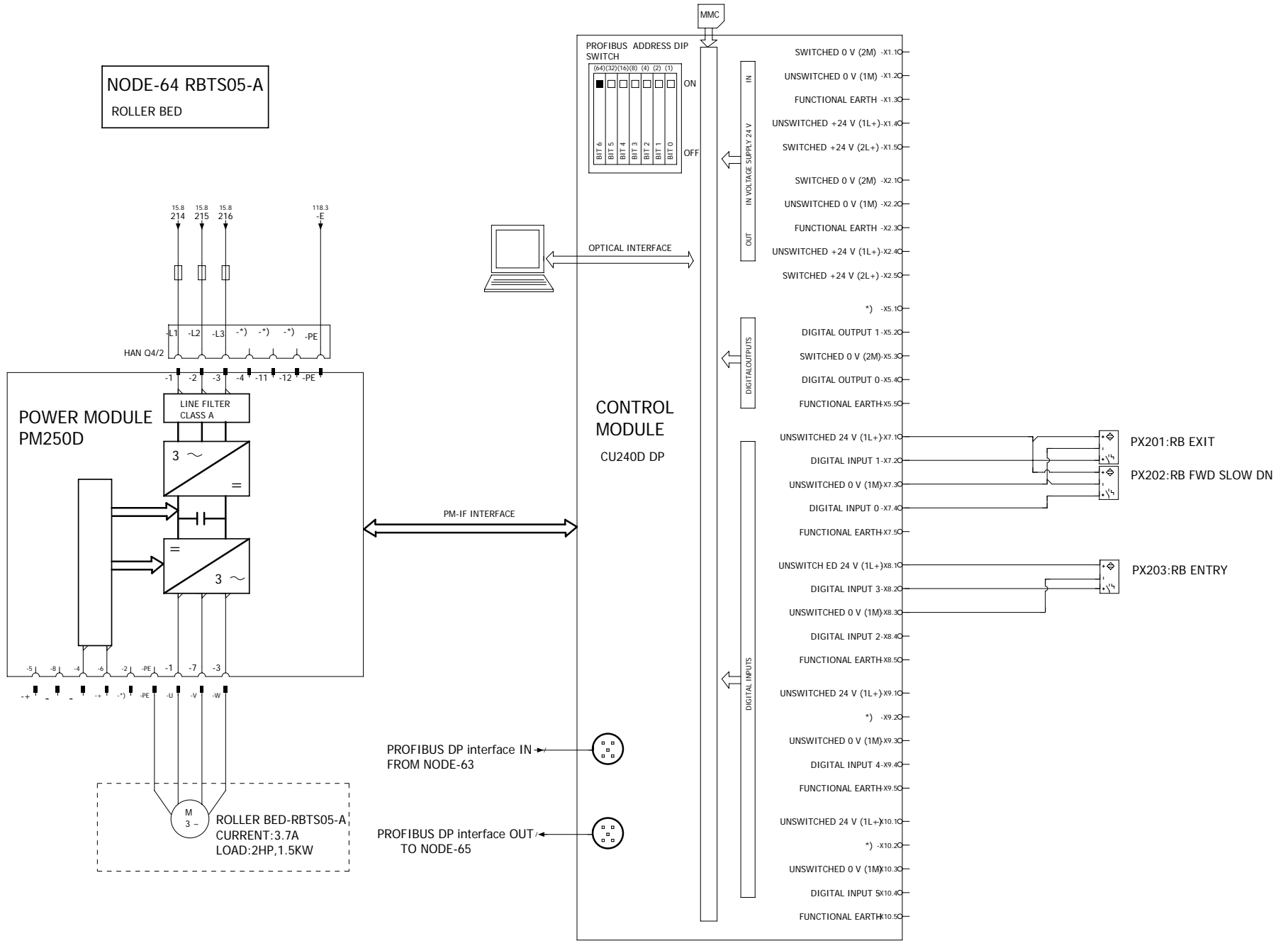

DOCUMENT ID : CY/DD/R/07
REV : 00

NODE-65 RBTS05-B
TRANSFER CAR DRIVE

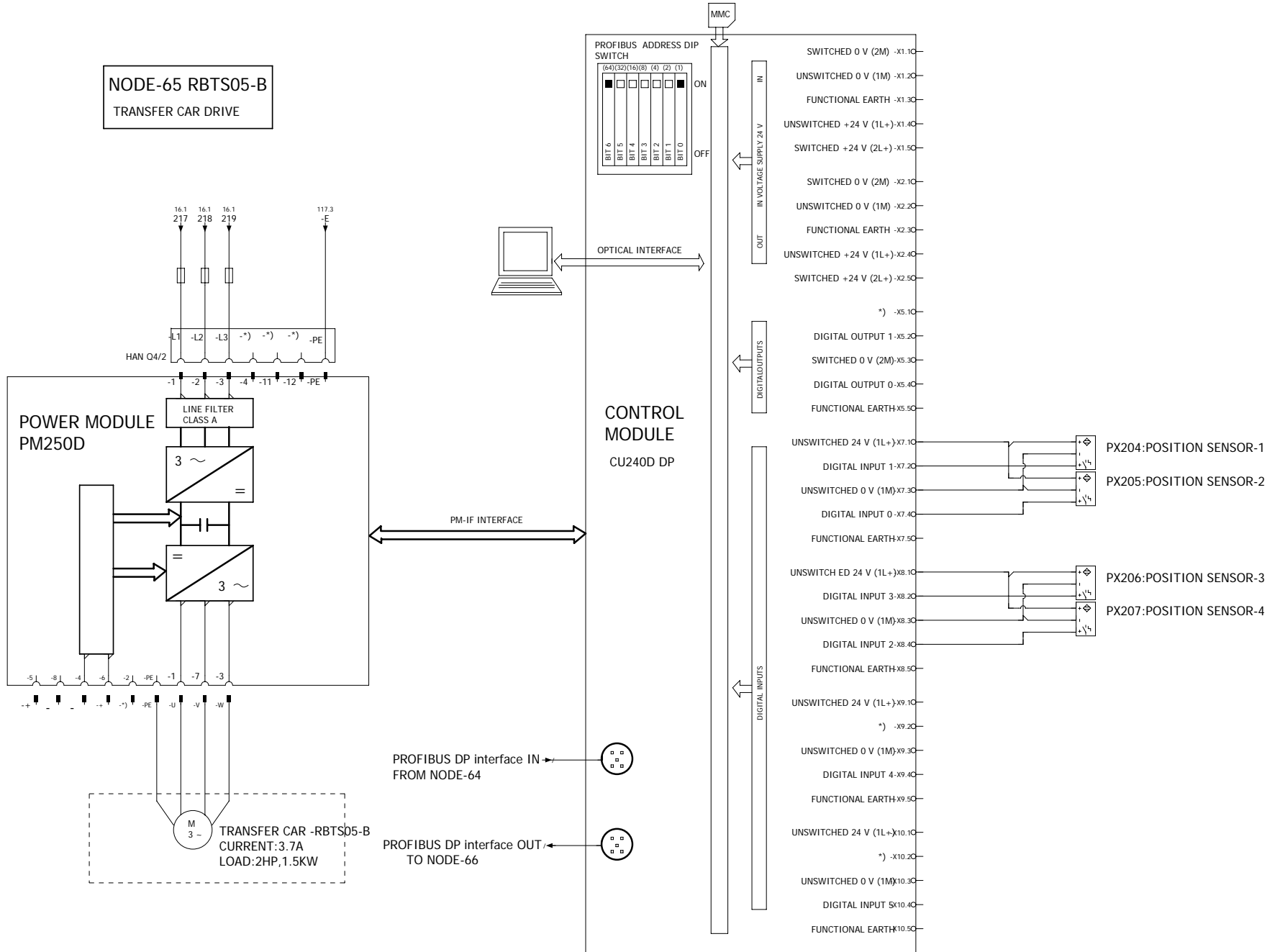

DOCUMENT ID : CY/DD/R/07
REV : 00

| | | |
|----------|------|--------|
| Drawn | Date | Name |
| Checked | | SHITAL |
| Approved | | |

| | |
|---------------------|---------------------|
| PROJECT DESCRIPTION | HA-382 VOLVO FRANCE |
|---------------------|---------------------|

| | |
|-------|---------|
| TITLE | NODE-65 |
|-------|---------|

| | |
|-------------------|---------------|
| PROJECT CODE :- | HA-382 |
| DRAWING NUMBER :- | |
| Page | 118 |
| Pages | 147 |

NODE-66 RBTS06-A
ROLLER BED DRIVE

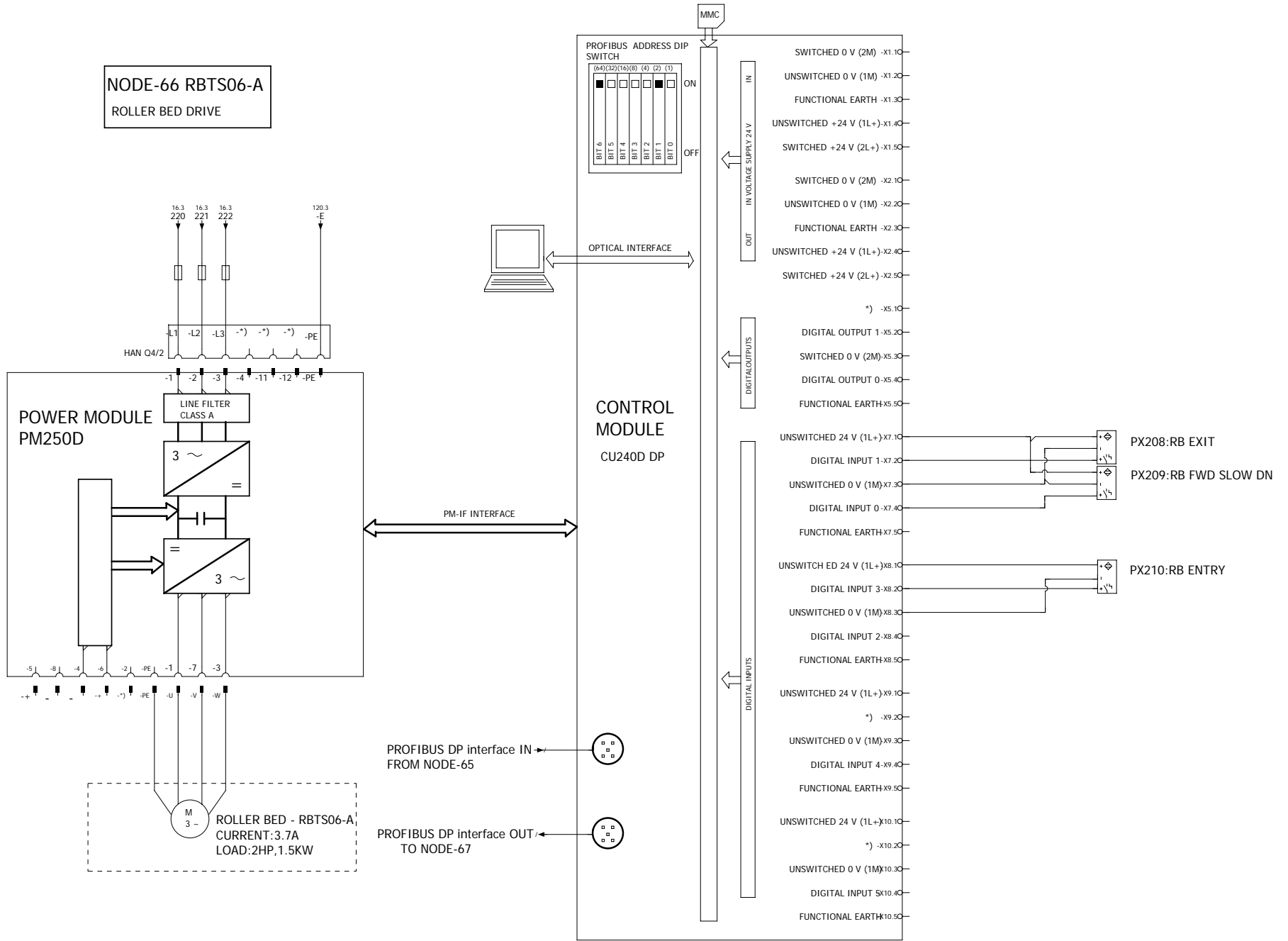

DOCUMENT ID : CY/DD/R/07

REV : 00



CYBERNETIK TECHNOLOGIES
PVT.LTD, PUNE

| | Date | Name |
|----------|------|--------|
| DRAWN | | SHITAL |
| CHECKED | | |
| APPROVED | | |

| PROJECT DESCRIPTION | TITLE |
|---------------------|---------|
| HA-382 VOLVO FRANCE | NODE-66 |

| PROJECT CODE :- | DRAWING NUMBER :- |
|-----------------|-------------------|
| HA-382 | |

| Page | Pages |
|------|-------|
| 119 | 147 |

NODE-67 RBTS06-B
TRANSFER CAR DRIVE

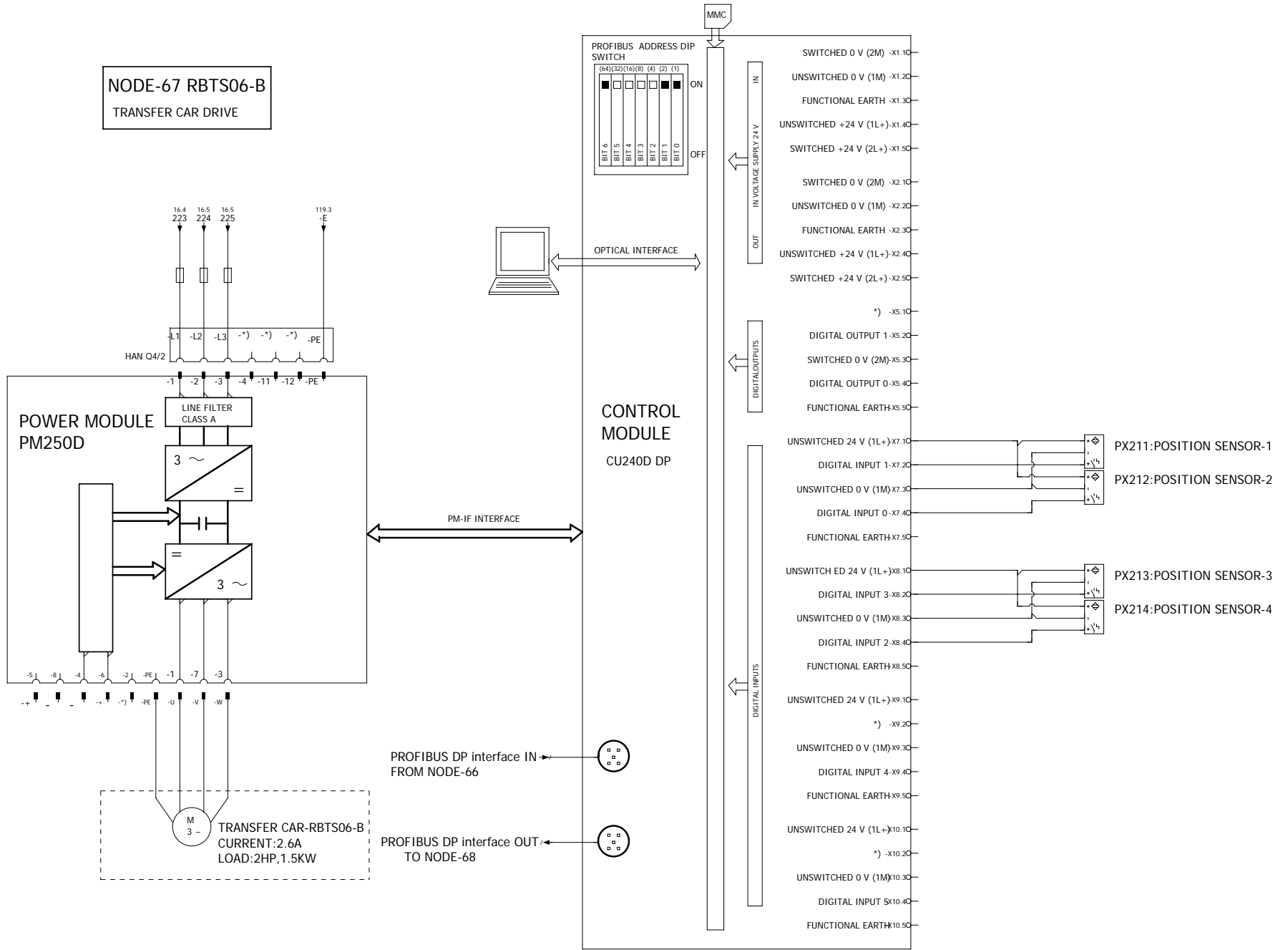

DOCUMENT ID : CY/DD/R/07
REV : 00

CYBERNETIK TECHNOLOGIES PVT.LTD, PUNE

| | |
|----------|--------|
| DATE | NAME |
| CHECKED | SHITAL |
| APPROVED | |

| | |
|---------------------|---------|
| PROJECT DESCRIPTION | TITLE |
| HA-382 VOLVO FRANCE | NODE-67 |

PROJECT CODE :- **HA-382**

DRAWING NUMBER :-

NODE-68 RB40
ROLLER BED

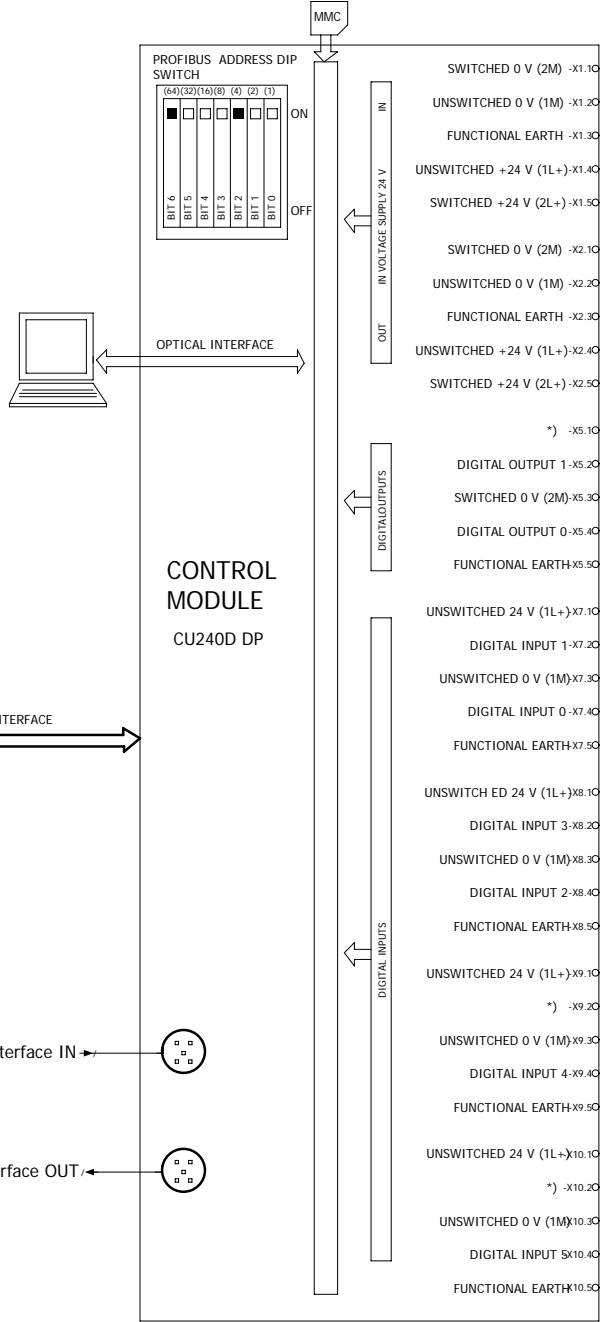
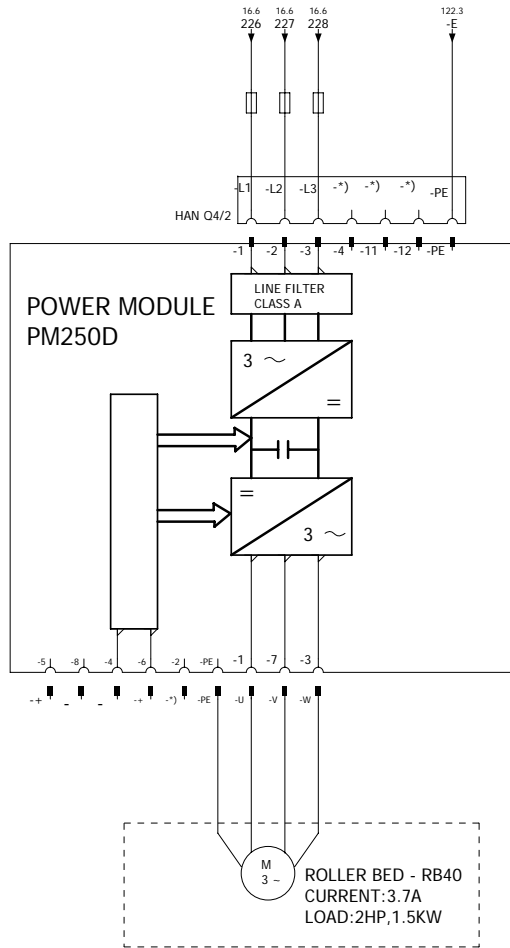

PROFIBUS DP interface IN FROM NODE-67

PROFIBUS DP interface OUT TO NODE-69

DOCUMENT ID : CY/DD/R/07
REV : 00

| | | |
|----------|------|--------|
| Drawn | Date | Name |
| Checked | | SHITAL |
| Approved | | |

NODE-69 RB41
ROLLER BED DRIVE

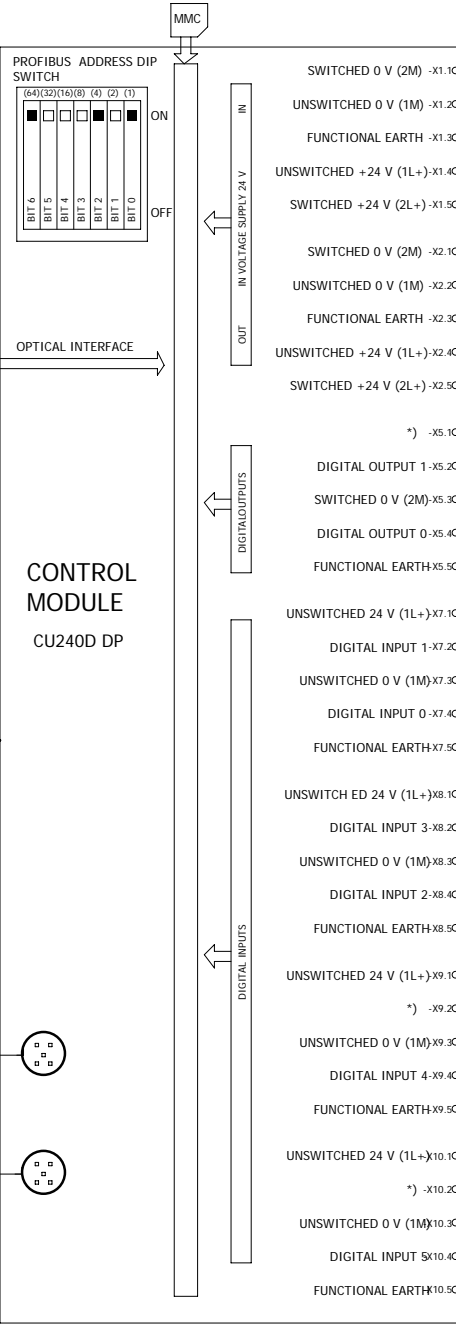
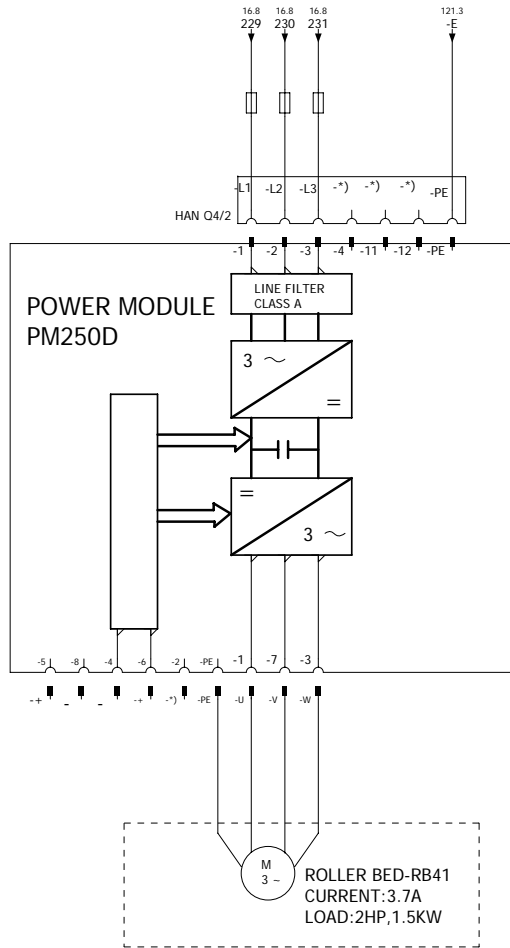

PROFIBUS DP interface IN FROM NODE-68

PROFIBUS DP interface OUT TO NODE-70

DOCUMENT ID : CY/DD/R/07
REV : 00

| | Date | Name |
|----------|------|--------|
| DRAWN | | SHITAL |
| CHECKED | | |
| APPROVED | | |

NODE-70 RB42
ROLLER BED DRIVE

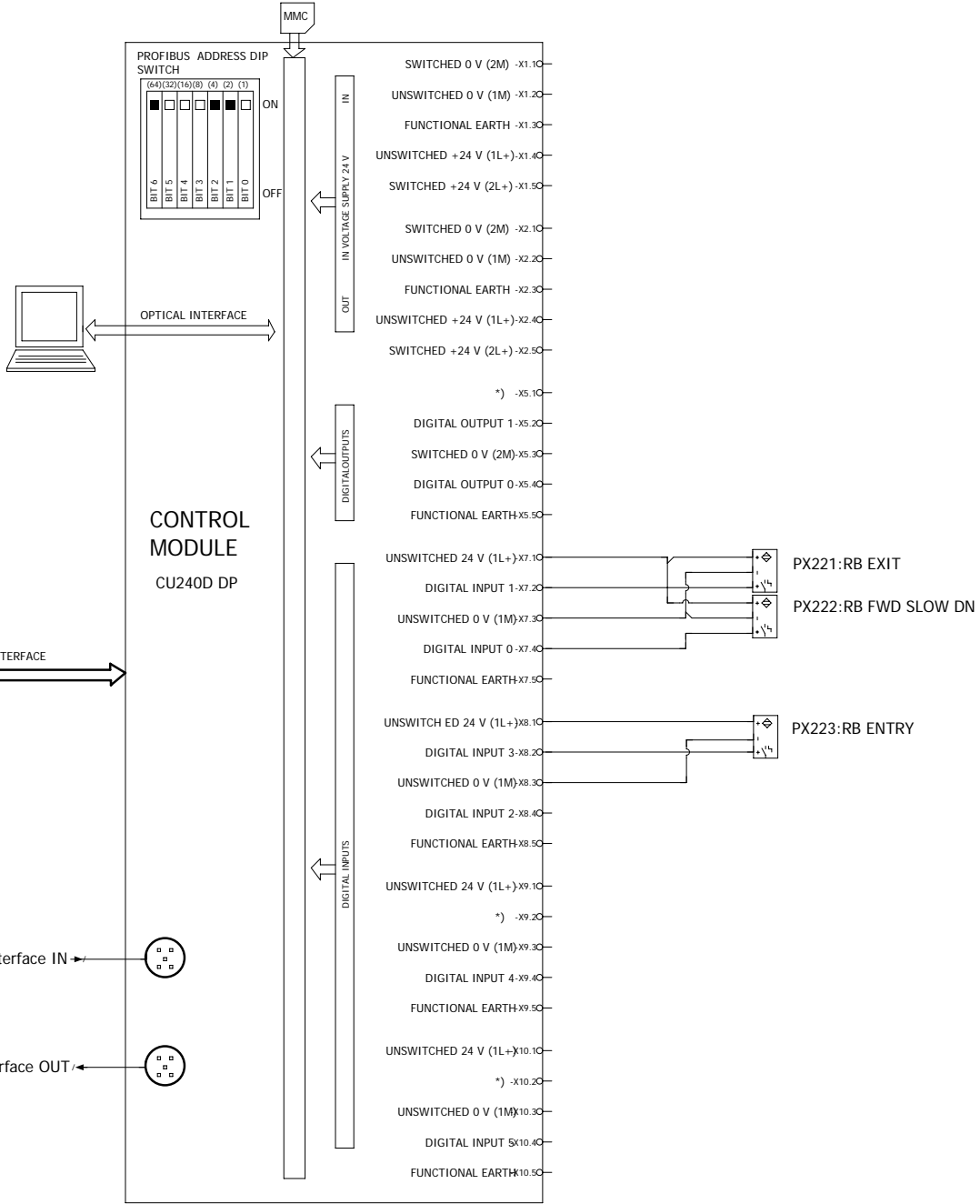
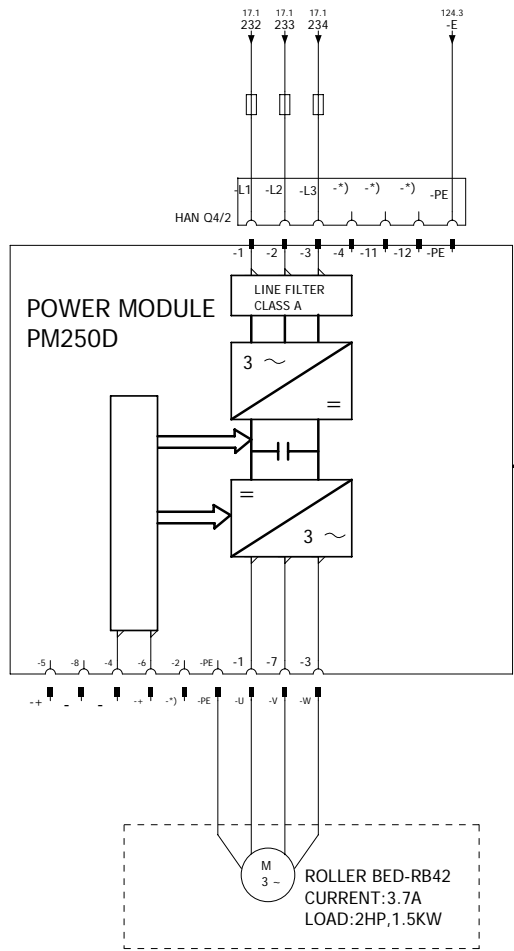

PM-IF INTERFACE

PROFIBUS DP interface IN FROM NODE-69

PROFIBUS DP interface OUT TO NODE-71

| | |
|----------|--------|
| DATE | NAME |
| | SHITAL |
| CHECKED | |
| APPROVED | |

| | |
|---------------------|---------|
| PROJECT DESCRIPTION | TITLE |
| HA-382 VOLVO FRANCE | NODE-70 |

| | |
|-------------------|--------|
| PROJECT CODE :- | HA-382 |
| DRAWING NUMBER :- | |

NODE-71 RB43
ROLLER BED DRIVE

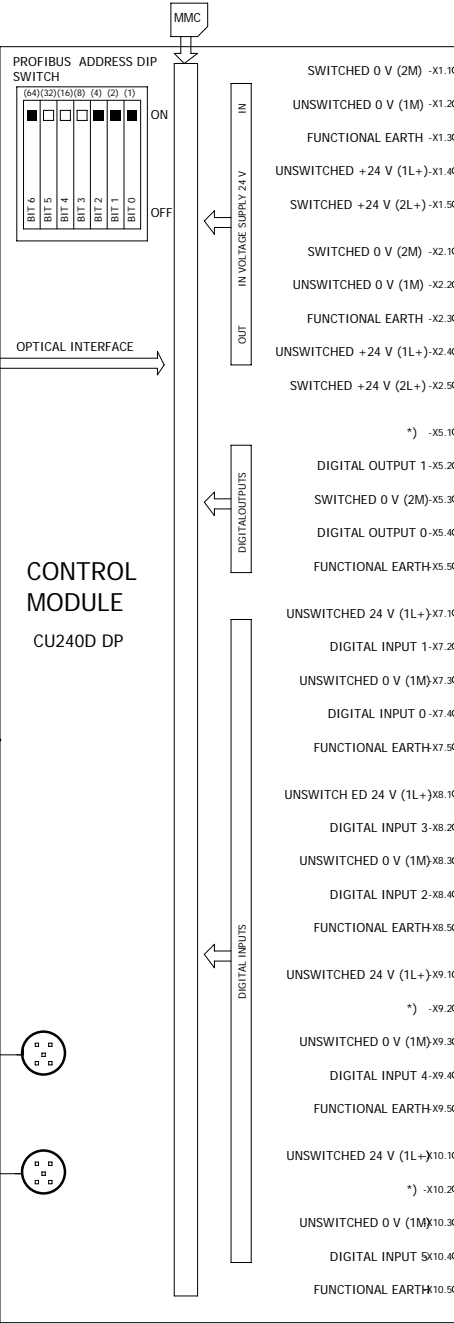
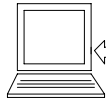
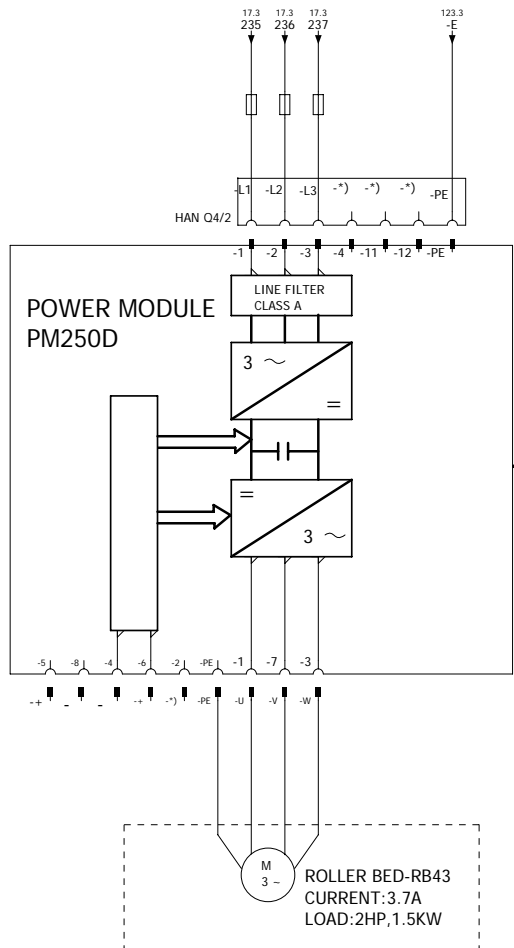

PROFIBUS DP interface IN FROM NODE-70

PROFIBUS DP interface OUT TO NODE-72

- SWITCHED 0 V (2M) -X1.10
- UNSWITCHED 0 V (1M) -X1.20
- FUNCTIONAL EARTH -X1.30
- UNSWITCHED +24 V (1L+) -X1.40
- SWITCHED +24 V (2L+) -X1.50
- SWITCHED 0 V (2M) -X2.10
- UNSWITCHED 0 V (1M) -X2.20
- FUNCTIONAL EARTH -X2.30
- UNSWITCHED +24 V (1L+) -X2.40
- SWITCHED +24 V (2L+) -X2.50
- *) -X5.10
- DIGITAL OUTPUT 1 -X5.20
- SWITCHED 0 V (2M) -X5.30
- DIGITAL OUTPUT 0 -X5.40
- FUNCTIONAL EARTH -X5.50
- UNSWITCHED 24 V (1L+) -X7.10
- DIGITAL INPUT 1 -X7.20
- UNSWITCHED 0 V (1M) -X7.30
- DIGITAL INPUT 0 -X7.40
- FUNCTIONAL EARTH -X7.50
- UNSWITCHED 24 V (1L+) -X8.10
- DIGITAL INPUT 3 -X8.20
- UNSWITCHED 0 V (1M) -X8.30
- DIGITAL INPUT 2 -X8.40
- FUNCTIONAL EARTH -X8.50
- UNSWITCHED 24 V (1L+) -X9.10
- *) -X9.20
- UNSWITCHED 0 V (1M) -X9.30
- DIGITAL INPUT 4 -X9.40
- FUNCTIONAL EARTH -X9.50
- UNSWITCHED 24 V (1L+) -X10.10
- *) -X10.20
- UNSWITCHED 0 V (1M) -X10.30
- DIGITAL INPUT 5 -X10.40
- FUNCTIONAL EARTH -X10.50

PX224:RB EXIT

PX225:RB FWD SLOW DN

PX226:RB ENTRY

| | |
|----------|--------|
| DATE | NAME |
| | SHITAL |
| CHECKED | |
| APPROVED | |

| | |
|---------------------|---------|
| PROJECT DESCRIPTION | TITLE |
| HA-382 VOLVO FRANCE | NODE-71 |

| | |
|-------------------|--------|
| PROJECT CODE :- | HA-382 |
| DRAWING NUMBER :- | |

NODE-72 RB44
ROLLER BED DRIVE

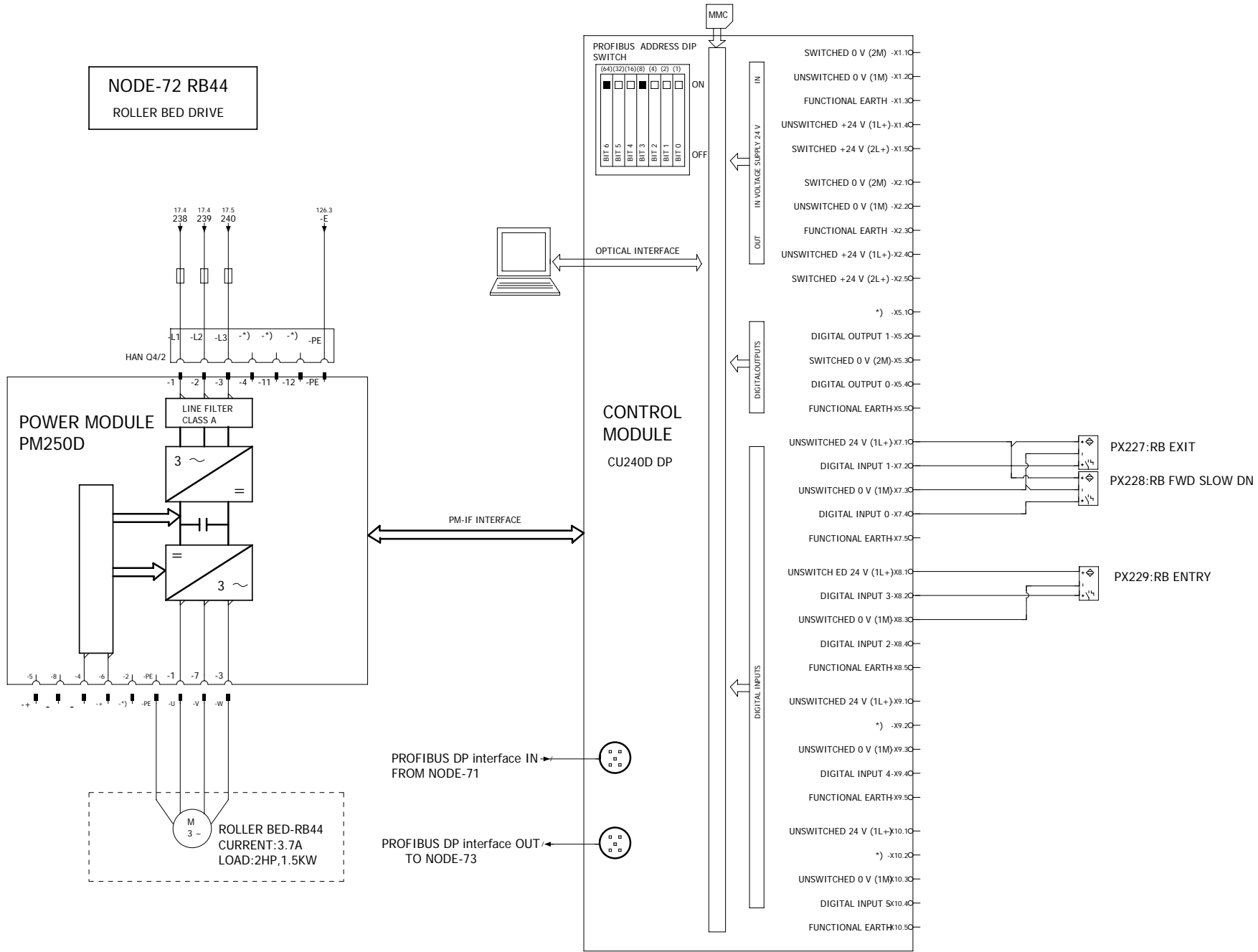

DOCUMENT ID : CY/DD/R/07
REV : 00



CYBERNETIK TECHNOLOGIES
PVT.LTD, PUNE

| | Date | Name |
|----------|------|--------|
| DRAWN | | SHITAL |
| CHECKED | | |
| APPROVED | | |

| PROJECT DESCRIPTION | TITLE |
|---------------------|---------|
| HA-382 VOLVO FRANCE | NODE-72 |

| PROJECT CODE :- | DRAWING NUMBER :- |
|-----------------|-------------------|
| HA-382 | |

| | |
|-------|-----|
| Page | 125 |
| Pages | 147 |

NODE-73 RB45
ROLLER BED DRIVE

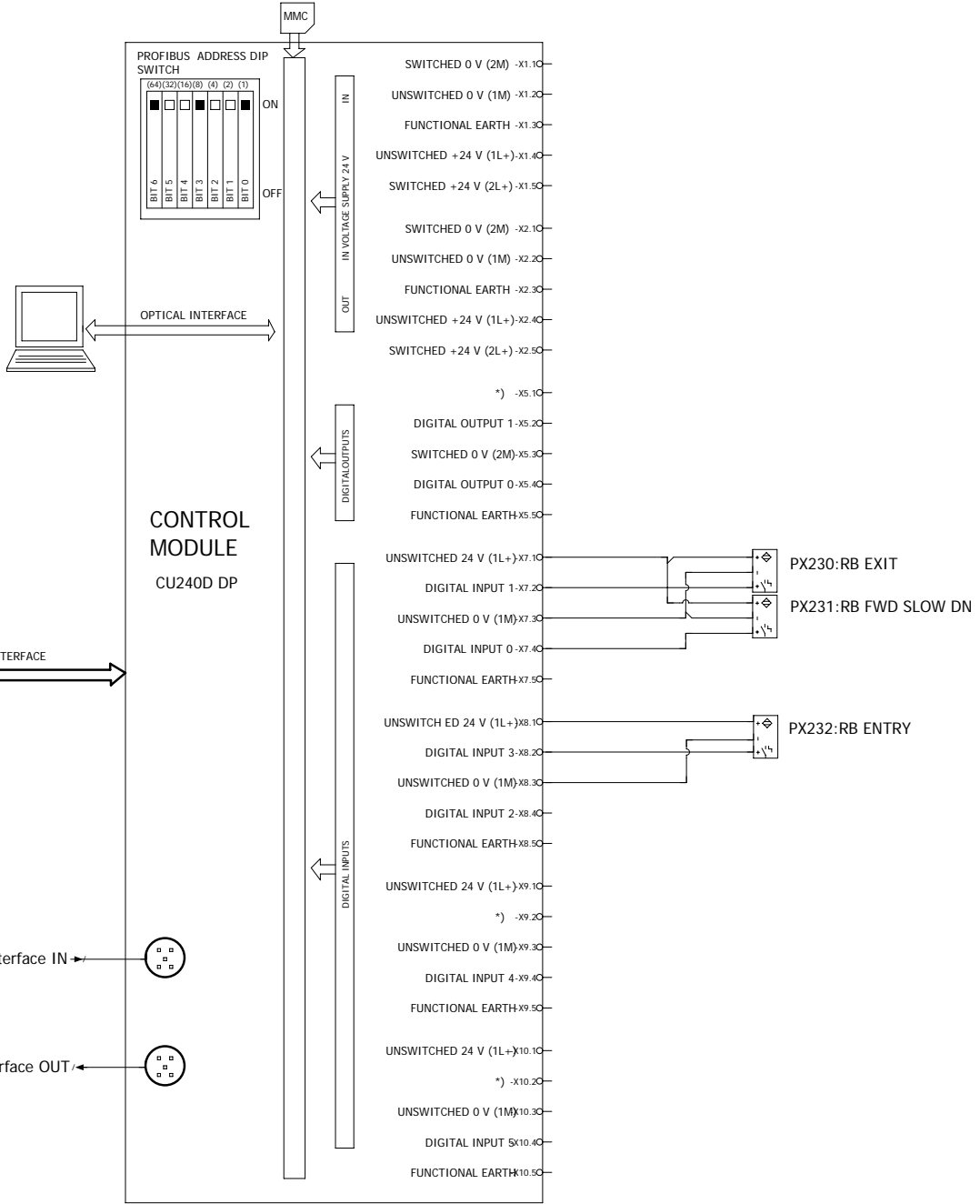
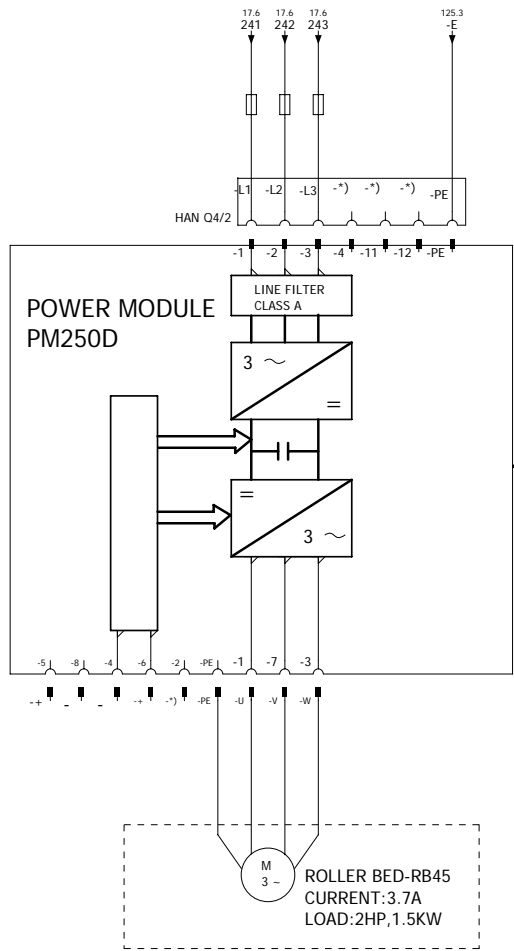

DOCUMENT ID : CY/DD/R/07
REV : 00



CYBERNETIK TECHNOLOGIES
PVT.LTD, PUNE

| | Date | Name |
|----------|------|--------|
| DRAWN | | SHITAL |
| CHECKED | | |
| APPROVED | | |

| PROJECT DESCRIPTION | TITLE |
|---------------------|---------|
| HA-382 VOLVO FRANCE | NODE-73 |

| PROJECT CODE :- | DRAWING NUMBER :- |
|-----------------|-------------------|
| HA-382 | |

| | |
|-------|-----|
| Page | 126 |
| Pages | 147 |

NODE-74 RB46
ROLLER BED DRIVE

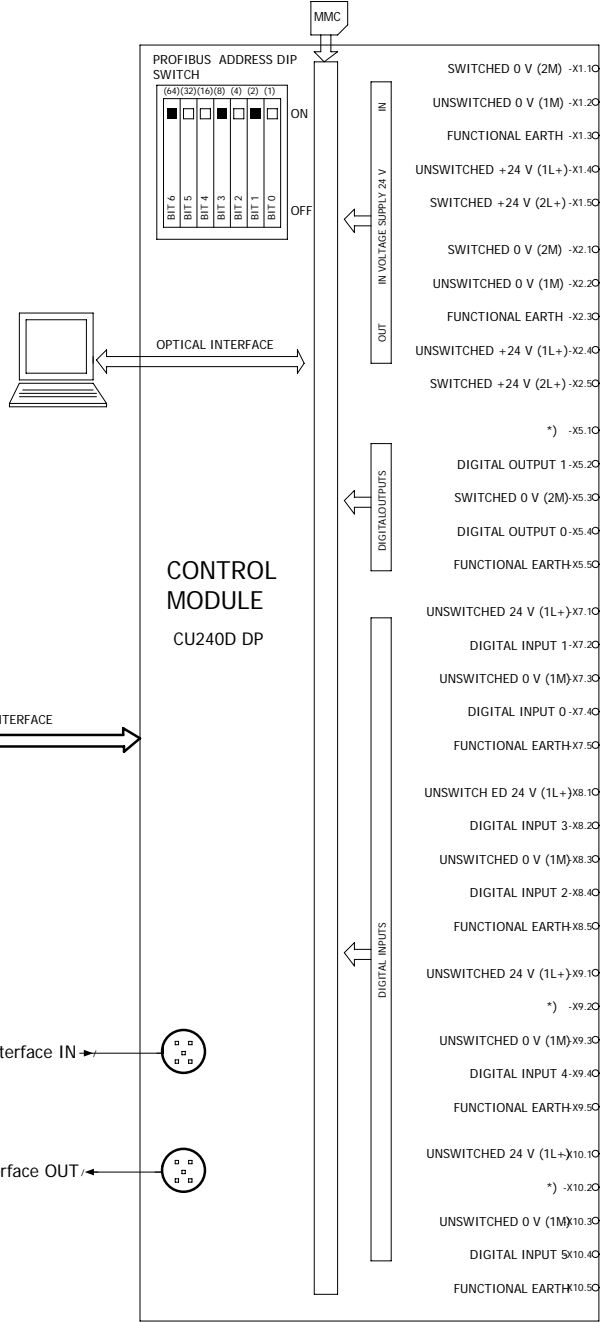
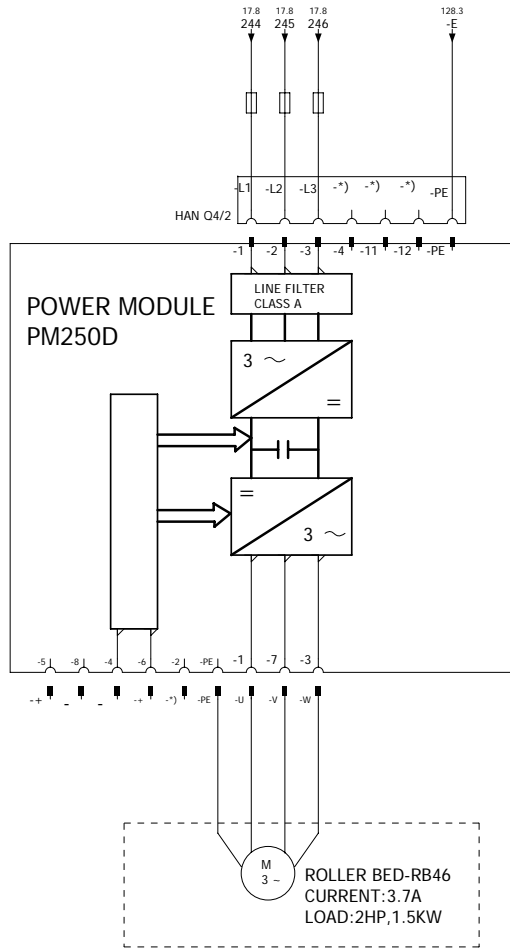

PROFIBUS DP interface IN FROM NODE-73

PROFIBUS DP interface OUT TO NODE-75

DOCUMENT ID : CY/DD/R/07
REV : 00

| | | |
|----------|------|--------|
| Drawn | Date | Name |
| Checked | | SHITAL |
| Approved | | |

NODE-75 RB47
ROLLER BED DRIVE

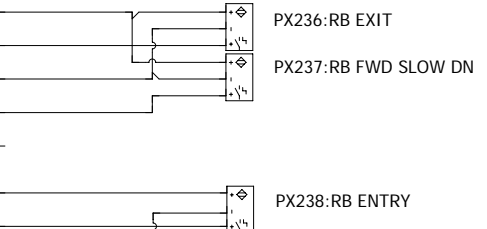
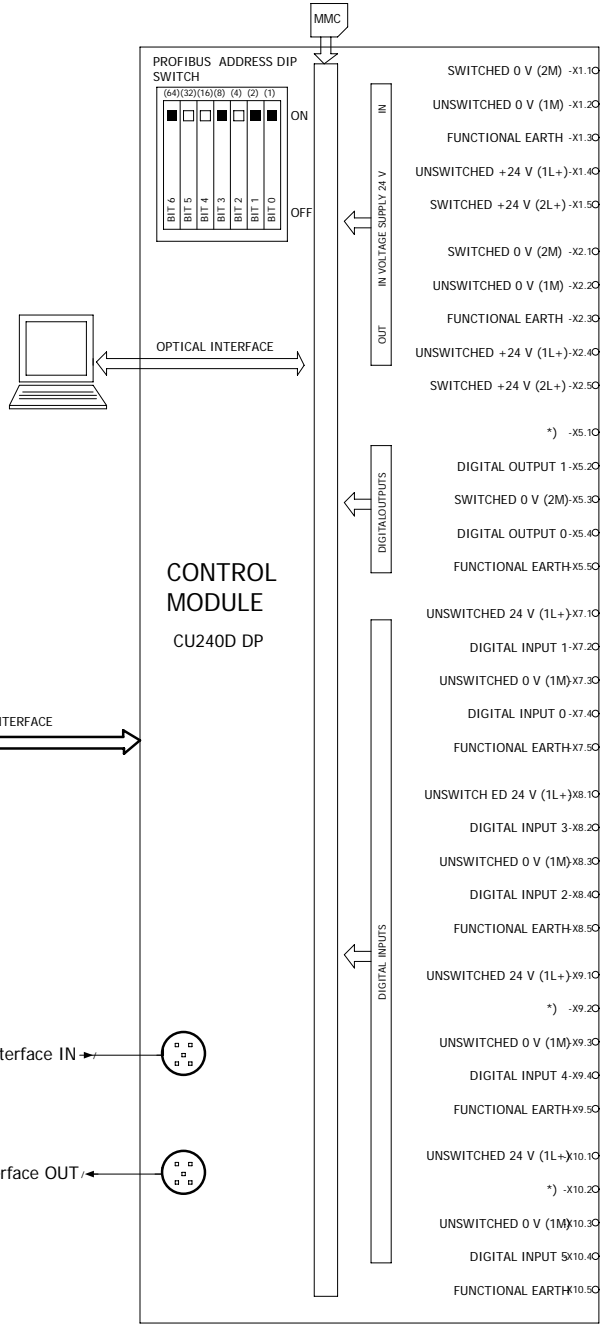
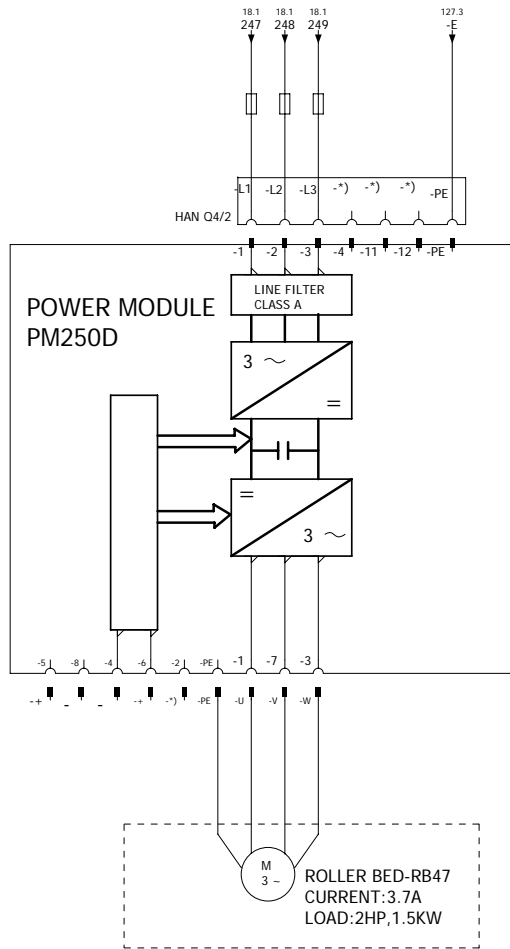

DOCUMENT ID : CY/DD/R/07
REV : 00

| | | |
|----------|------|--------|
| Drawn | Date | Name |
| Checked | | SHITAL |
| Approved | | |

| | |
|---------------------|---------|
| PROJECT DESCRIPTION | TITLE |
| HA-382 VOLVO FRANCE | NODE-75 |

| | |
|-------------------|--------|
| PROJECT CODE :- | HA-382 |
| DRAWING NUMBER :- | |

NODE-76 RB48
ROLLER BED DRIVE

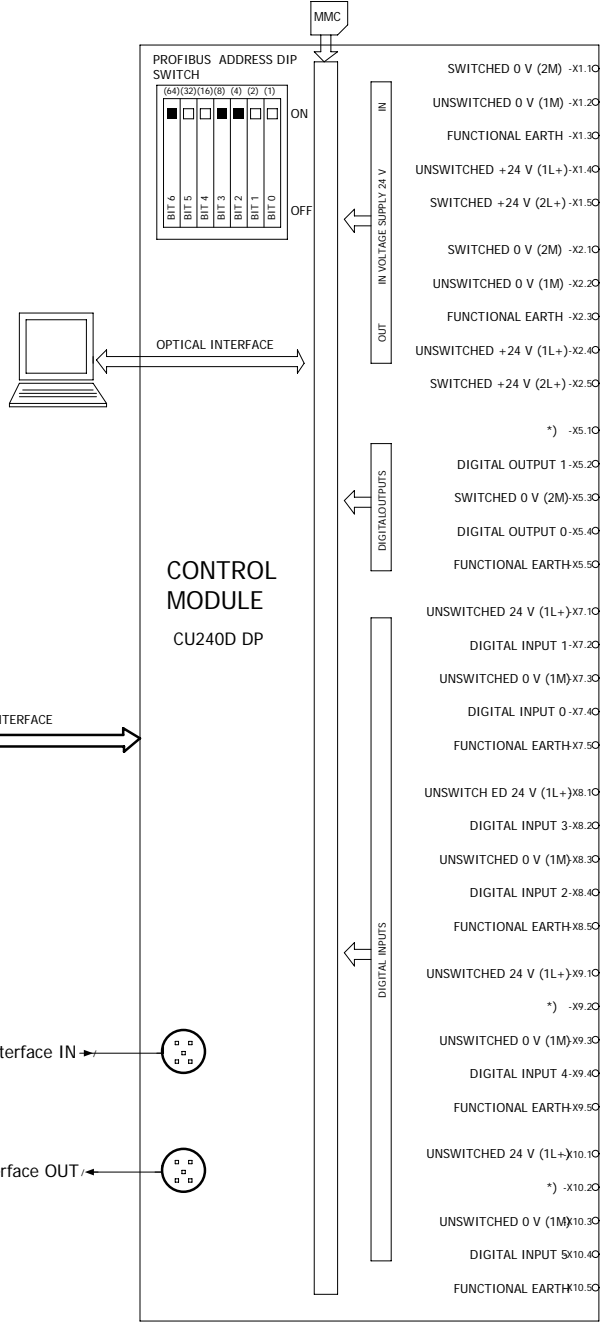
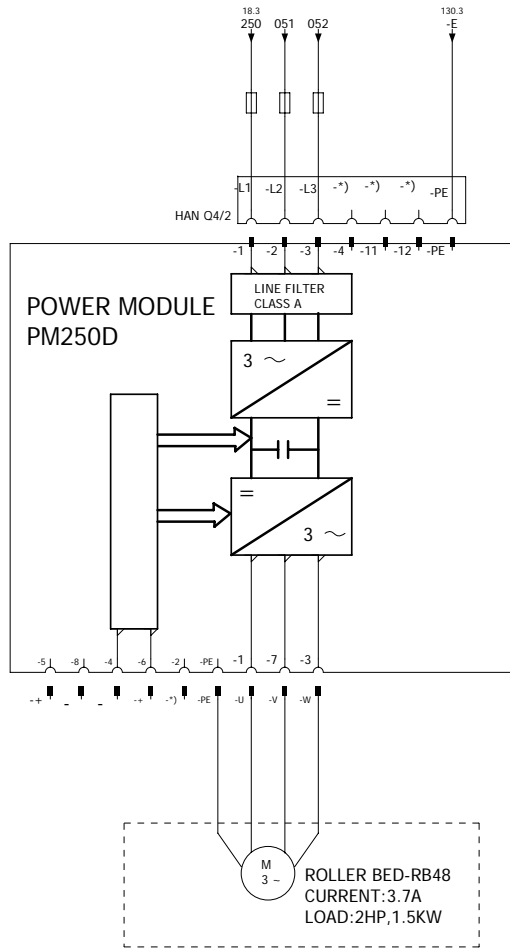

PROFIBUS DP interface IN FROM NODE-75

PROFIBUS DP interface OUT TO NODE-77

DOCUMENT ID : CY/DD/R/07
REV : 00

| | |
|----------|--------|
| DATE | NAME |
| | SHITAL |
| CHECKED | |
| APPROVED | |

NODE-77 RB49
ROLLER BED DRIVE

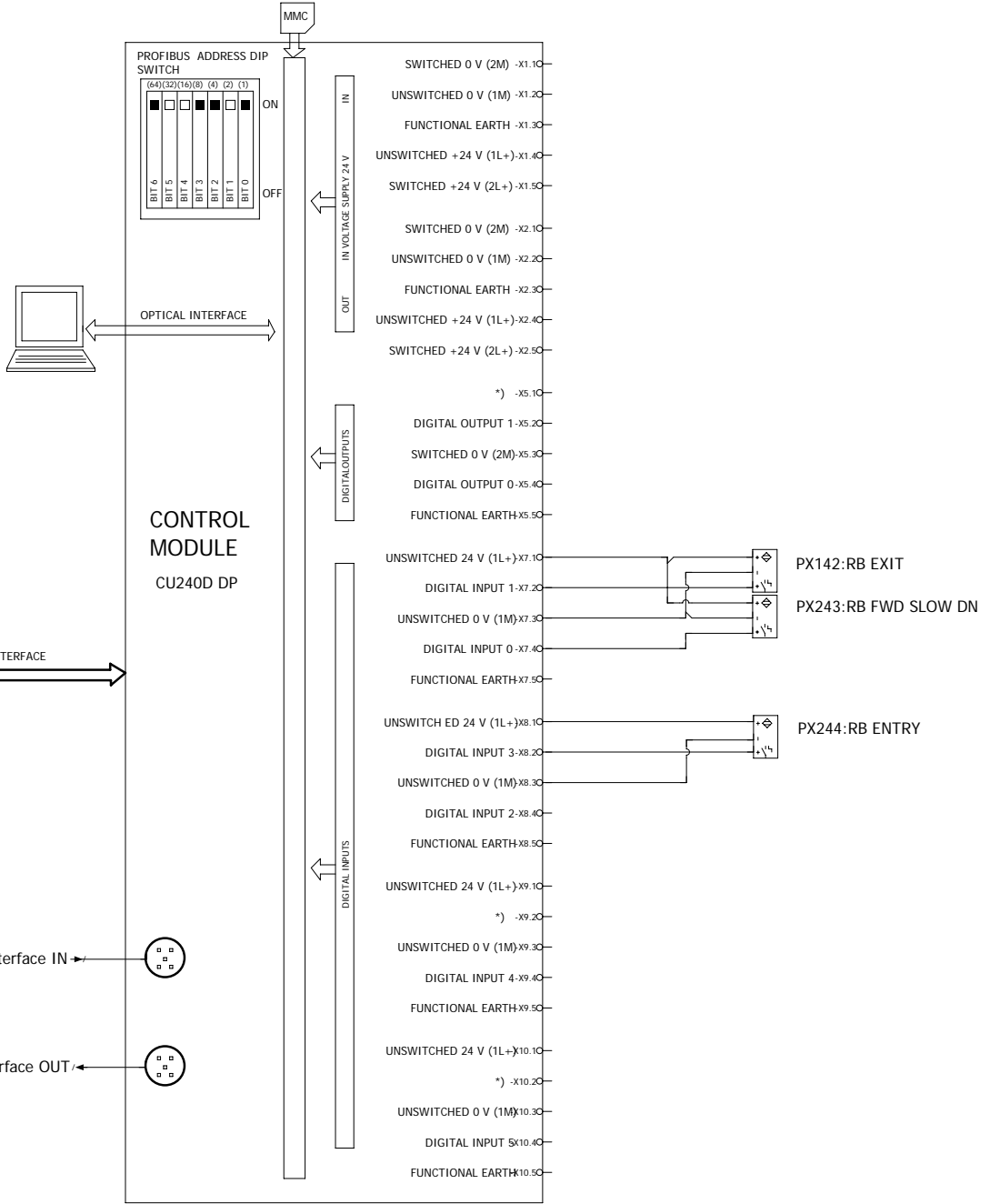
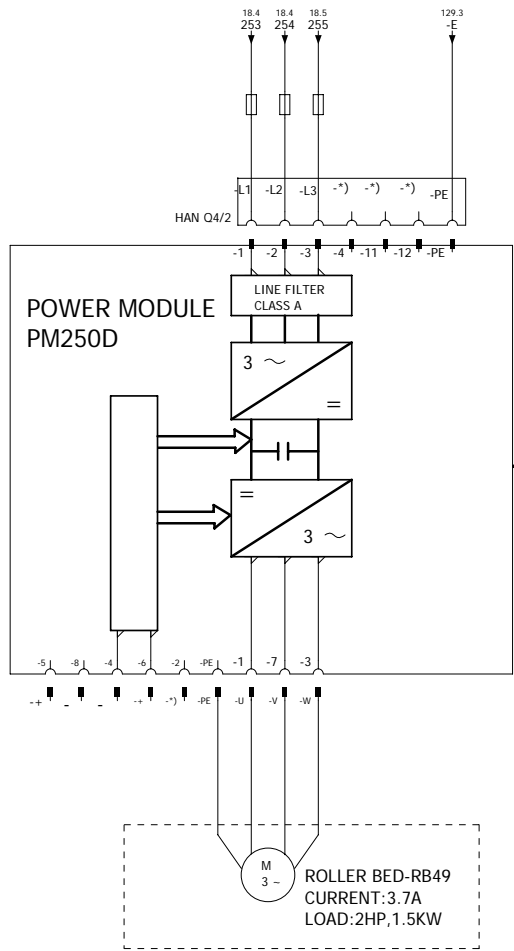

PM-IF INTERFACE

PROFIBUS DP interface IN FROM NODE-76

PROFIBUS DP interface OUT TO NODE-78



| | Date | Name |
|----------|------|--------|
| DRAWN | | SHITAL |
| CHECKED | | |
| APPROVED | | |

| PROJECT DESCRIPTION | TITLE |
|---------------------|---------|
| HA-382 VOLVO FRANCE | NODE-77 |

| PROJECT CODE :- | DRAWING NUMBER :- |
|-----------------|-------------------|
| HA-382 | |

NODE-78 RB50
ROLLER BED DRIVE

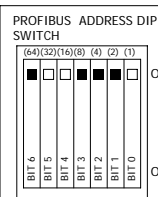
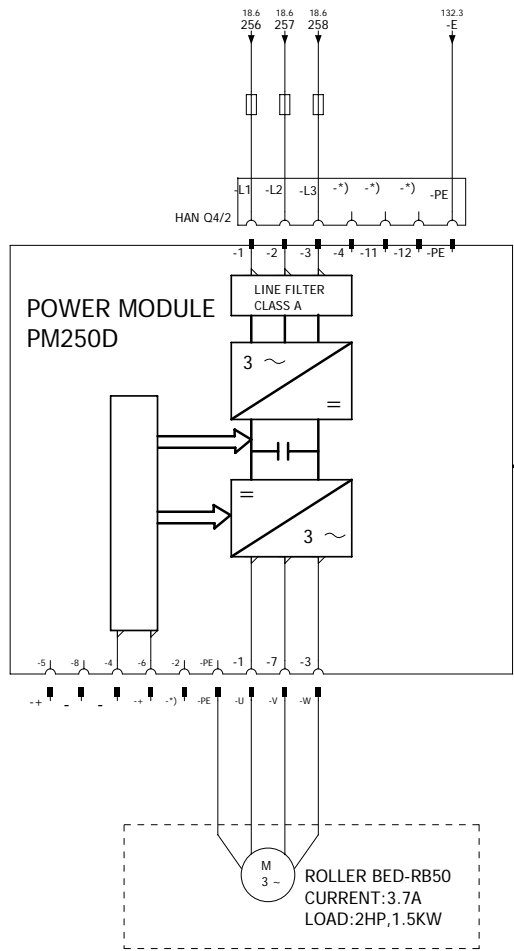

OPTICAL INTERFACE

CONTROL MODULE
CU240D DP

PM-IF INTERFACE

PROFIBUS DP interface IN FROM NODE-77

PROFIBUS DP interface OUT TO NODE-79

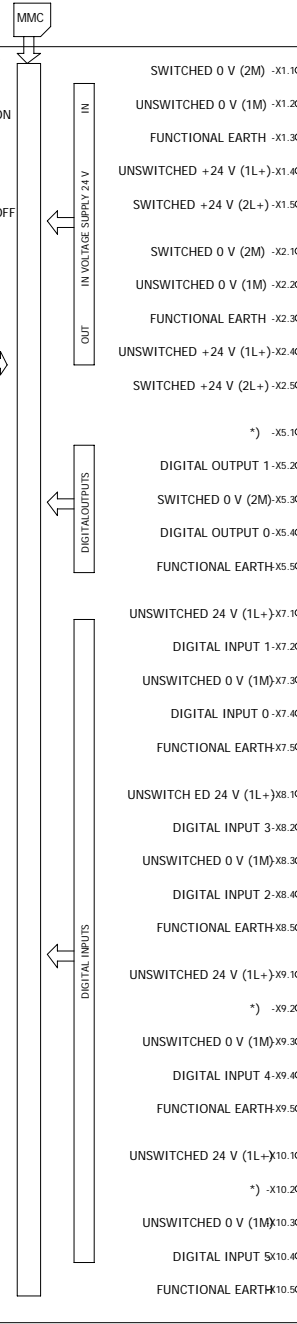

DOCUMENT ID : CY/DD/R/07

REV : 00



CYBERNETIK TECHNOLOGIES
PVT.LTD, PUNE

| | | |
|----------|------|--------|
| DRAWN | Date | Name |
| CHECKED | | SHITAL |
| APPROVED | | |

| | |
|---------------------|---------|
| PROJECT DESCRIPTION | TITLE |
| HA-382 VOLVO FRANCE | NODE-78 |

| | |
|-------------------|--------|
| PROJECT CODE :- | HA-382 |
| DRAWING NUMBER :- | |

| | |
|-------|-----|
| Page | 131 |
| Pages | 147 |

NODE-79 RB51
ROLLER BED DRIVE

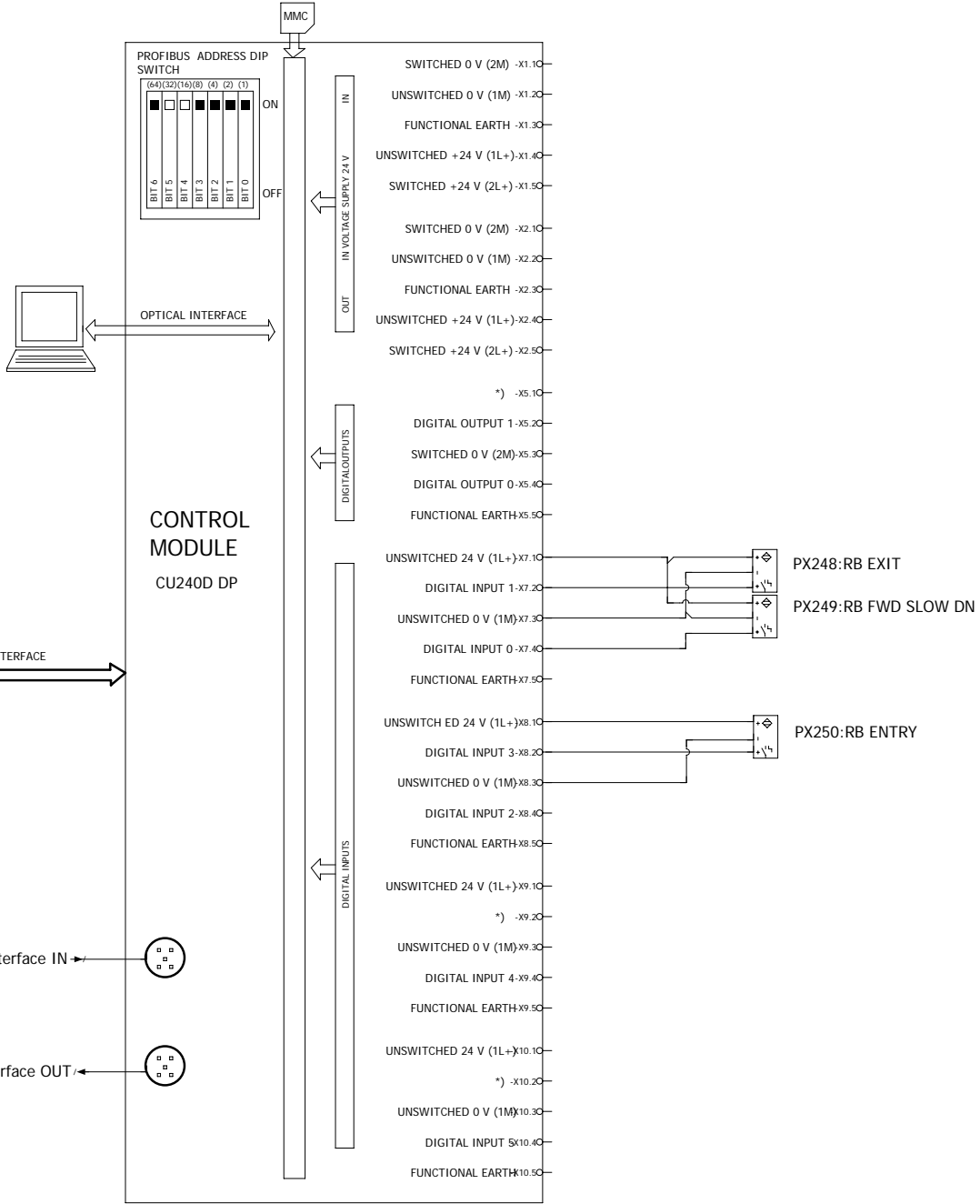
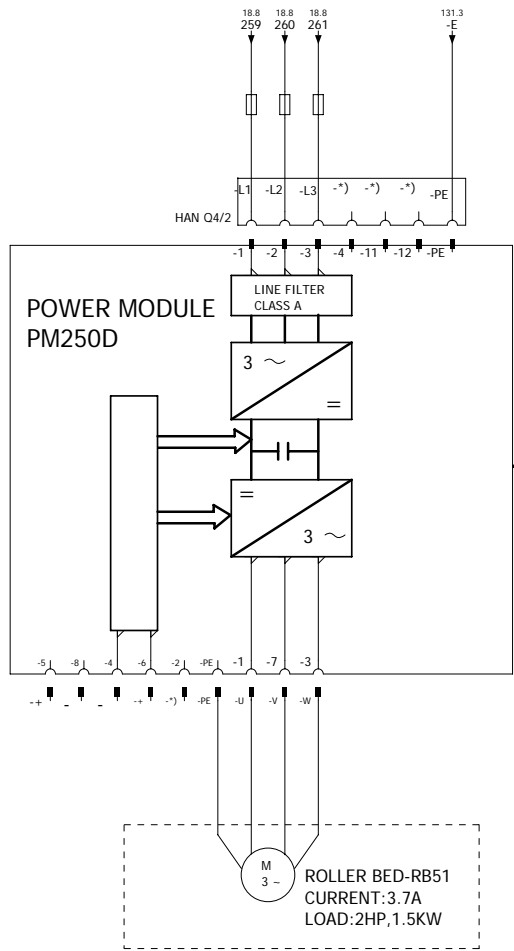

PM-IF INTERFACE

PROFIBUS DP interface IN FROM NODE-78

PROFIBUS DP interface OUT TO NODE-80

DOCUMENT ID : CY/DD/R/07

REV : 00



CYBERNETIK TECHNOLOGIES
PVT.LTD, PUNE

| | Date | Name |
|----------|------|--------|
| DRAWN | | SHITAL |
| CHECKED | | |
| APPROVED | | |

PROJECT DESCRIPTION
HA-382 VOLVO FRANCE

TITLE
NODE-79

| | |
|-------------------|---------------|
| PROJECT CODE :- | HA-382 |
| DRAWING NUMBER :- | |
| Page | 132 |
| Pages | 147 |

NODE-80 RB52
ROLLER BED DRIVE

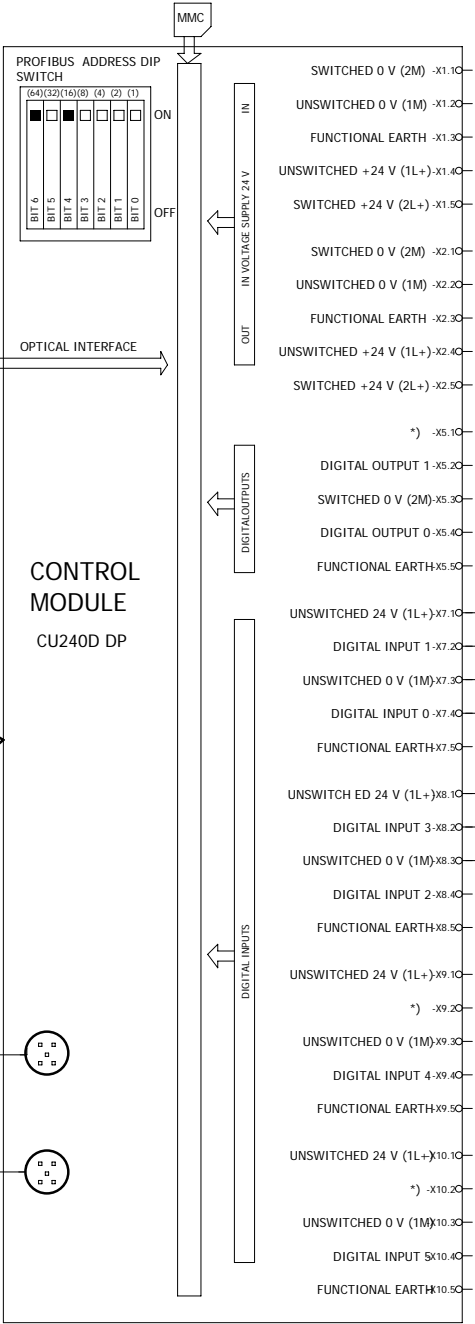
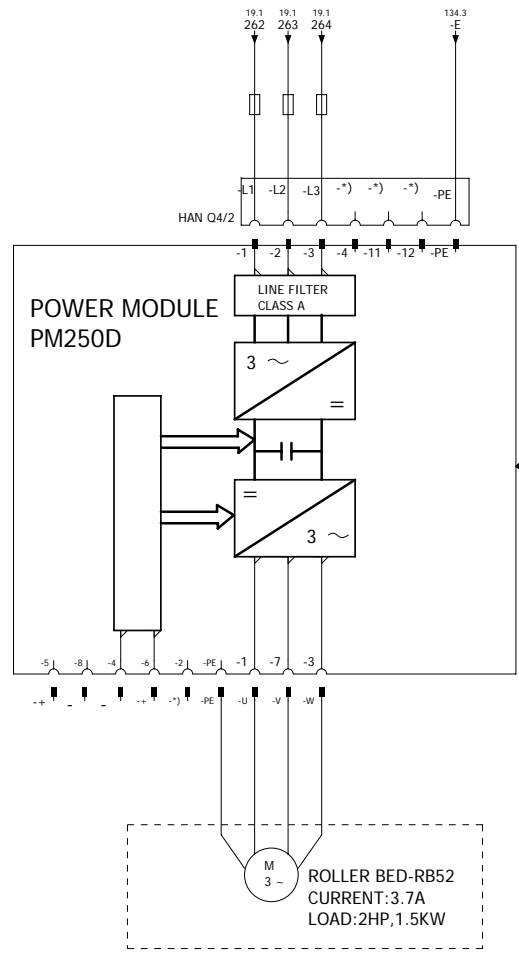

PM-IF INTERFACE

PROFIBUS DP interface IN FROM NODE-79

PROFIBUS DP interface OUT TO NODE-81

- SWITCHED 0 V (2M) -X1.10
- UNSWITCHED 0 V (1M) -X1.20
- FUNCTIONAL EARTH -X1.30
- UNSWITCHED +24 V (1L+) -X1.40
- SWITCHED +24 V (2L+) -X1.50
- SWITCHED 0 V (2M) -X2.10
- UNSWITCHED 0 V (1M) -X2.20
- FUNCTIONAL EARTH -X2.30
- UNSWITCHED +24 V (1L+) -X2.40
- SWITCHED +24 V (2L+) -X2.50
- *) -X5.10
- DIGITAL OUTPUT 1 -X5.20
- SWITCHED 0 V (2M) -X5.30
- DIGITAL OUTPUT 0 -X5.40
- FUNCTIONAL EARTH -X5.50
- UNSWITCHED 24 V (1L+) -X7.10
- DIGITAL INPUT 1 -X7.20
- UNSWITCHED 0 V (1M) -X7.30
- DIGITAL INPUT 0 -X7.40
- FUNCTIONAL EARTH -X7.50
- UNSWITCHED 24 V (1L+) -X8.10
- DIGITAL INPUT 3 -X8.20
- UNSWITCHED 0 V (1M) -X8.30
- DIGITAL INPUT 2 -X8.40
- FUNCTIONAL EARTH -X8.50
- UNSWITCHED 24 V (1L+) -X9.10
- *) -X9.20
- UNSWITCHED 0 V (1M) -X9.30
- DIGITAL INPUT 4 -X9.40
- FUNCTIONAL EARTH -X9.50
- UNSWITCHED 24 V (1L+) -X10.10
- *) -X10.20
- UNSWITCHED 0 V (1M) -X10.30
- DIGITAL INPUT 5 -X10.40
- FUNCTIONAL EARTH -X10.50

PX251:RB EXIT
PX252:RB FWD SLOW DN
PX253:RB ENTRY



| | Date | Name |
|----------|------|--------|
| DRAWN | | SHITAL |
| CHECKED | | |
| APPROVED | | |

| PROJECT DESCRIPTION | TITLE |
|---------------------|---------|
| HA-382 VOLVO FRANCE | NODE-80 |

| PROJECT CODE :- | DRAWING NUMBER :- |
|-----------------|-------------------|
| HA-382 | |

NODE-81 RB53
ROLLER BED DRIVE

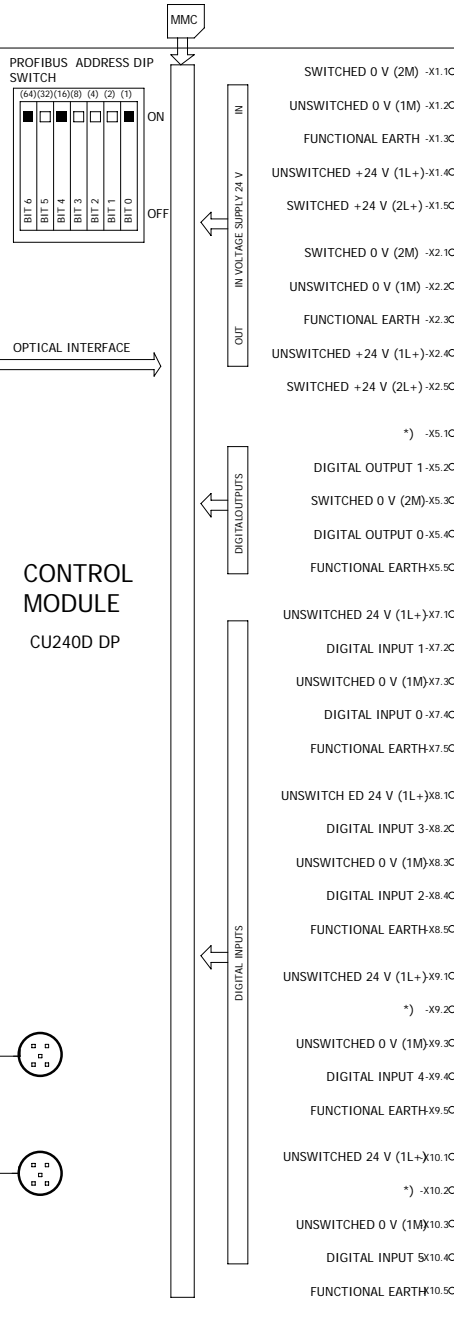
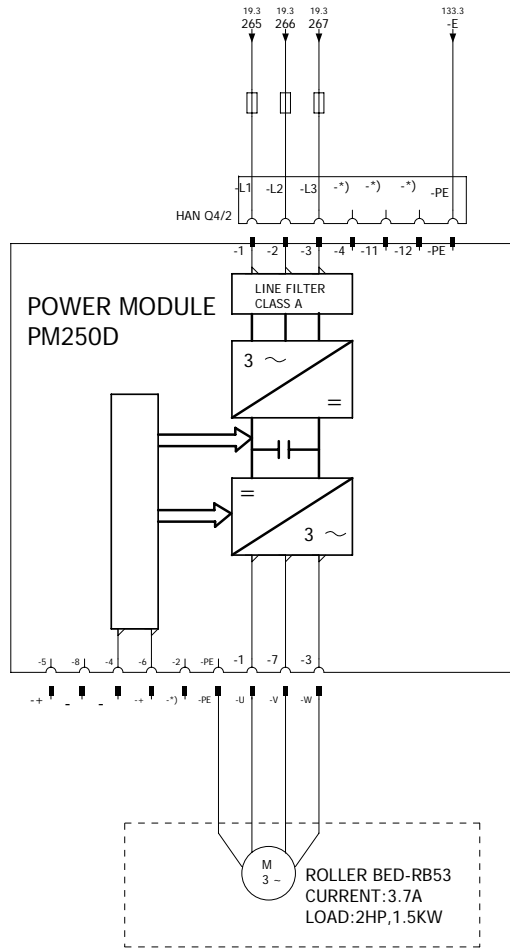

PM-IF INTERFACE

PROFIBUS DP interface IN FROM NODE-80

PROFIBUS DP interface OUT TO NODE-82

- SWITCHED 0 V (2M) -X1.1C
- UNSWITCHED 0 V (1M) -X1.2C
- FUNCTIONAL EARTH -X1.3C
- UNSWITCHED +24 V (1L+) -X1.4C
- SWITCHED +24 V (2L+) -X1.5C
- SWITCHED 0 V (2M) -X2.1C
- UNSWITCHED 0 V (1M) -X2.2C
- FUNCTIONAL EARTH -X2.3C
- UNSWITCHED +24 V (1L+) -X2.4C
- SWITCHED +24 V (2L+) -X2.5C
- *) -X5.1C
- DIGITAL OUTPUT 1 -X5.2C
- SWITCHED 0 V (2M) -X5.3C
- DIGITAL OUTPUT 0 -X5.4C
- FUNCTIONAL EARTH -X5.5C
- UNSWITCHED 24 V (1L+) -X7.1C
- DIGITAL INPUT 1 -X7.2C
- UNSWITCHED 0 V (1M) -X7.3C
- DIGITAL INPUT 0 -X7.4C
- FUNCTIONAL EARTH -X7.5C
- UNSWITCHED 24 V (1L+) -X8.1C
- DIGITAL INPUT 3 -X8.2C
- UNSWITCHED 0 V (1M) -X8.3C
- DIGITAL INPUT 2 -X8.4C
- FUNCTIONAL EARTH -X8.5C
- UNSWITCHED 24 V (1L+) -X9.1C
- *) -X9.2C
- UNSWITCHED 0 V (1M) -X9.3C
- DIGITAL INPUT 4 -X9.4C
- FUNCTIONAL EARTH -X9.5C
- UNSWITCHED 24 V (1L+) -X10.1C
- *) -X10.2C
- UNSWITCHED 0 V (1M) -X10.3C
- DIGITAL INPUT 5 -X10.4C
- FUNCTIONAL EARTH -X10.5C

PX254:RB EXIT
PX255:RB FWD SLOW DN
PX256:RB ENTRY

| | |
|----------|--------|
| DATE | NAME |
| CHECKED | SHITAL |
| APPROVED | |

| | |
|---------------------|---------|
| PROJECT DESCRIPTION | TITLE |
| HA-382 VOLVO FRANCE | NODE-81 |

| | |
|-------------------|--------|
| PROJECT CODE :- | HA-382 |
| DRAWING NUMBER :- | |

NODE-82 RB54
ROLLER BED DRIVE

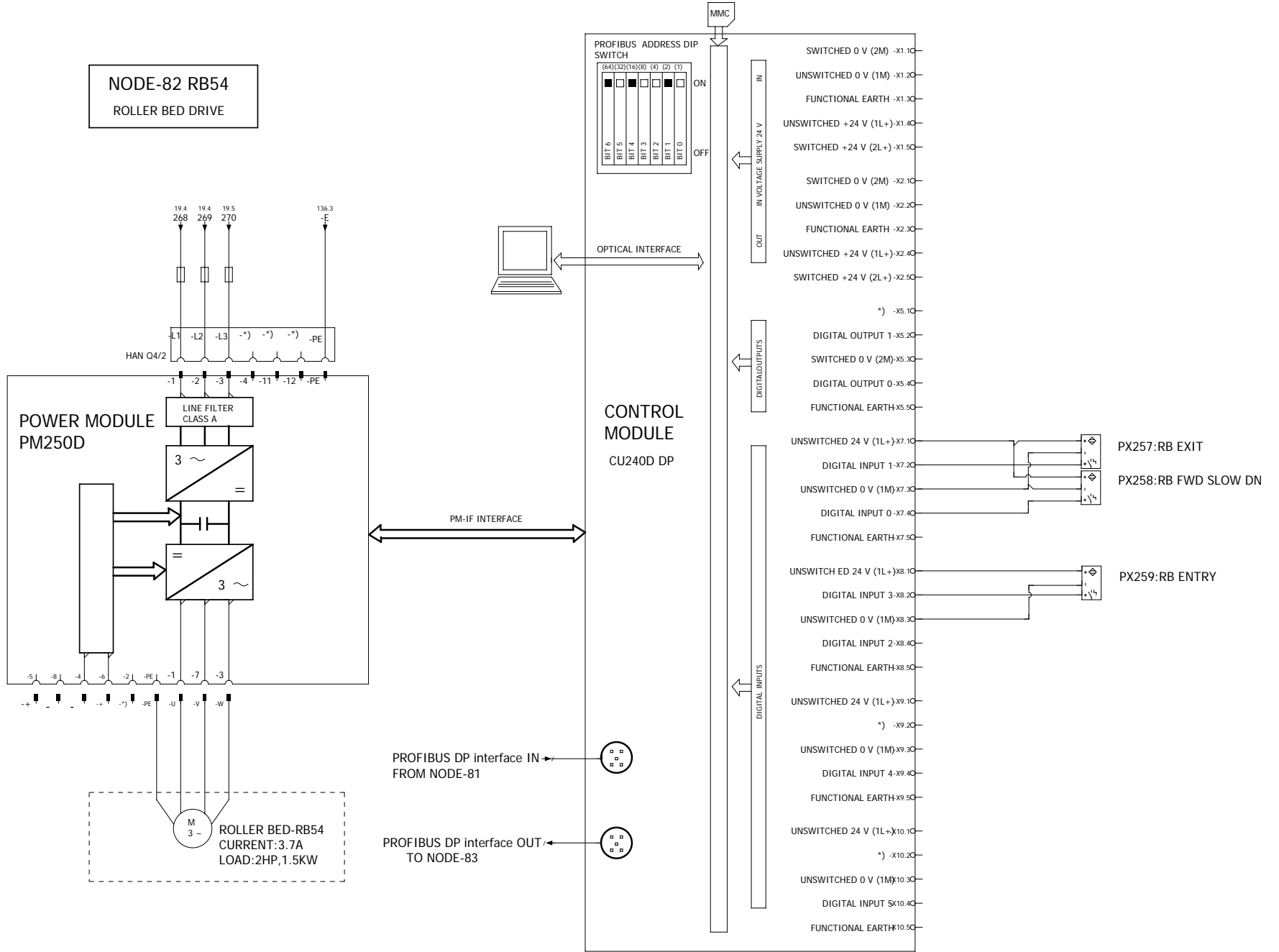

DOCUMENT ID : CY/DD/R/07
REV : 00

| | | |
|----------|------|--------|
| Drawn | Date | Name |
| Checked | | SHITAL |
| Approved | | |

| | |
|----------------------------|--------------|
| PROJECT DESCRIPTION | TITLE |
| HA-382 VOLVO FRANCE | NODE-82 |

| | |
|--------------------------|---------------|
| PROJECT CODE :- | HA-382 |
| DRAWING NUMBER :- | |

NODE-83 RB55
ROLLER BED DRIVE

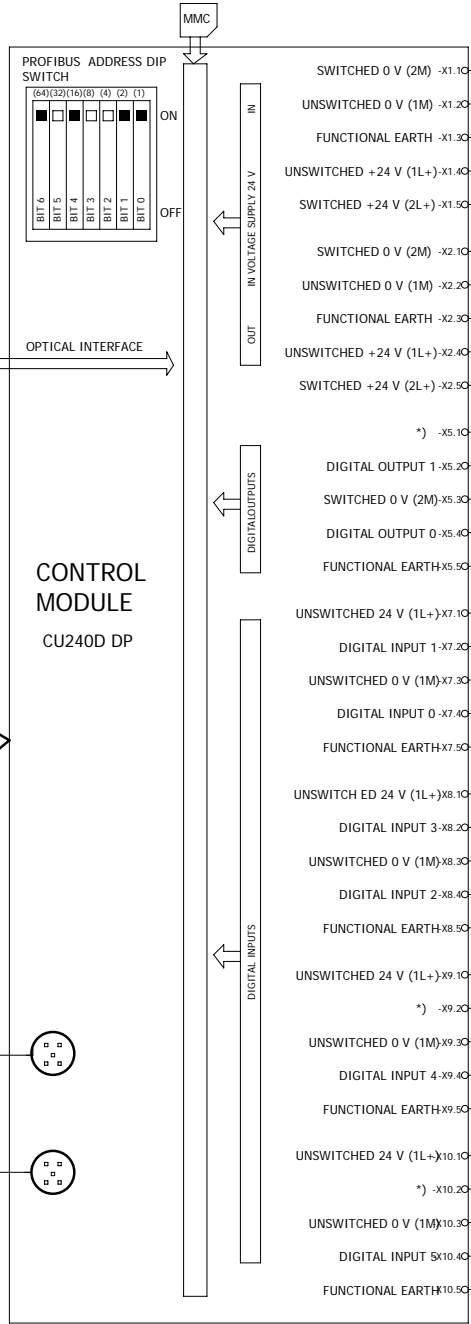
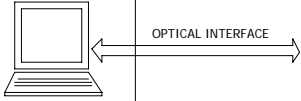
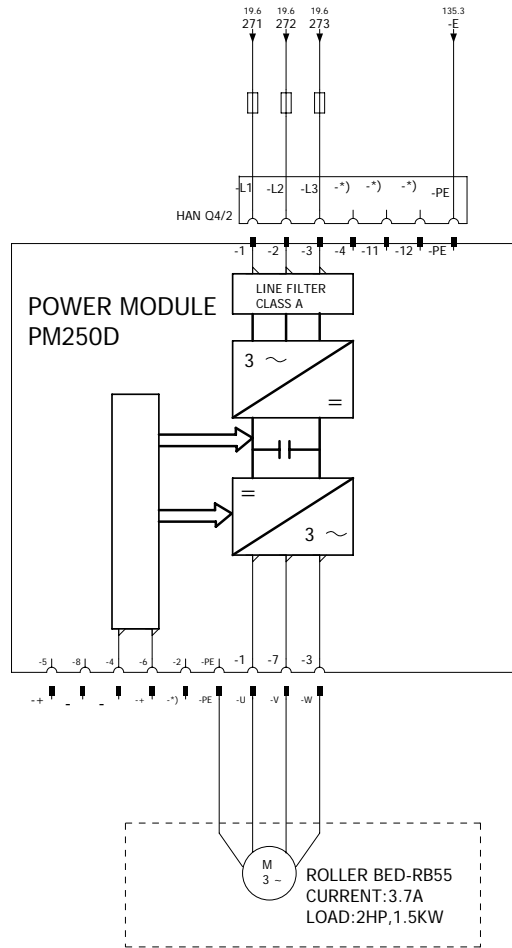

PM-IF INTERFACE

PROFIBUS DP interface IN FROM NODE-82

PROFIBUS DP interface OUT TO NODE-84

DOCUMENT ID : CY/DD/R/07
REV : 00

CYBERNETIK TECHNOLOGIES PVT.LTD, PUNE

| | | |
|----------|------|--------|
| Drawn | Date | Name |
| Checked | | SHITAL |
| Approved | | |

PROJECT DESCRIPTION
HA-382 VOLVO FRANCE

TITLE
NODE-83

PROJECT CODE :- **HA-382**
DRAWING NUMBER :-

NODE-84 RB56
ROLLER BED DRIVE

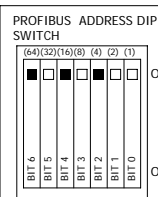
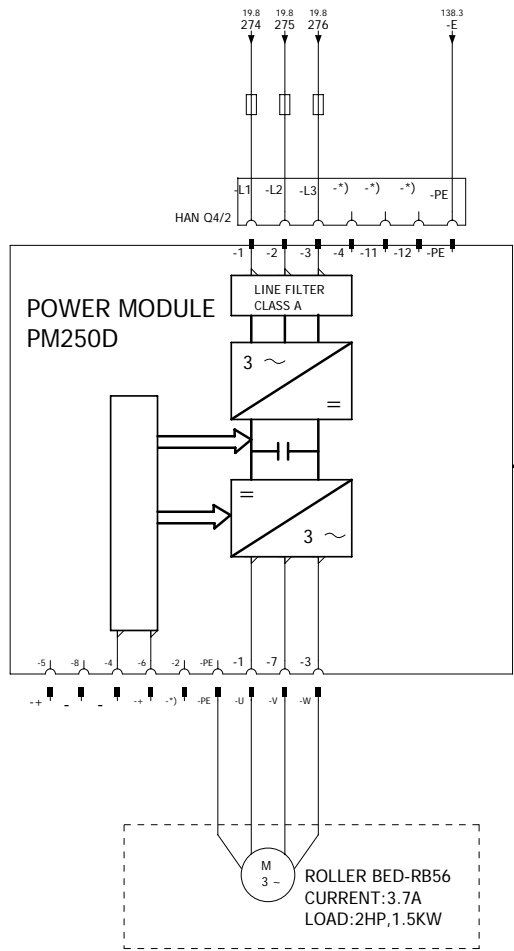

CONTROL MODULE
CU240D DP

PM-IF INTERFACE

PROFIBUS DP interface IN FROM NODE-83

PROFIBUS DP interface OUT TO NODE-85

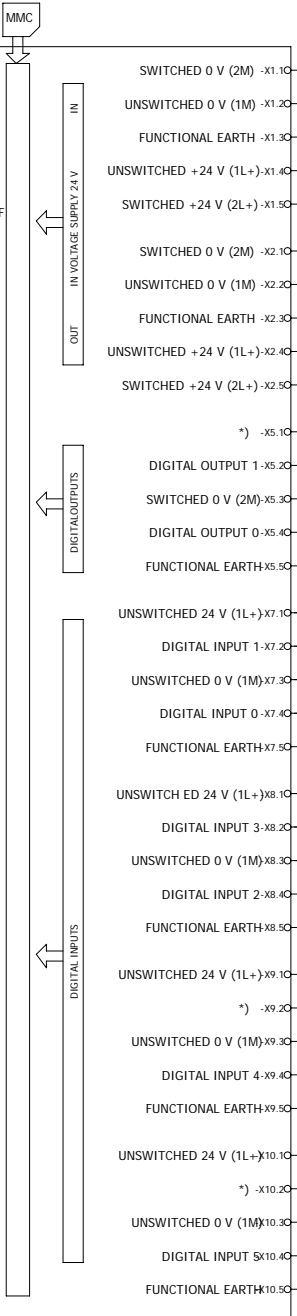

DOCUMENT ID : CY/DD/R/07

REV : 00

CYBERNETIK TECHNOLOGIES PVT.LTD, PUNE

| | |
|----------|--------|
| DATE | NAME |
| | SHITAL |
| CHECKED | |
| APPROVED | |

PROJECT DESCRIPTION
HA-382 VOLVO FRANCE

TITLE
NODE-84

| | |
|-------------------|--------|
| PROJECT CODE :- | HA-382 |
| DRAWING NUMBER :- | |
| Page | 137 |
| Pages | 147 |

NODE-85 RB57
ROLLER BED DRIVE

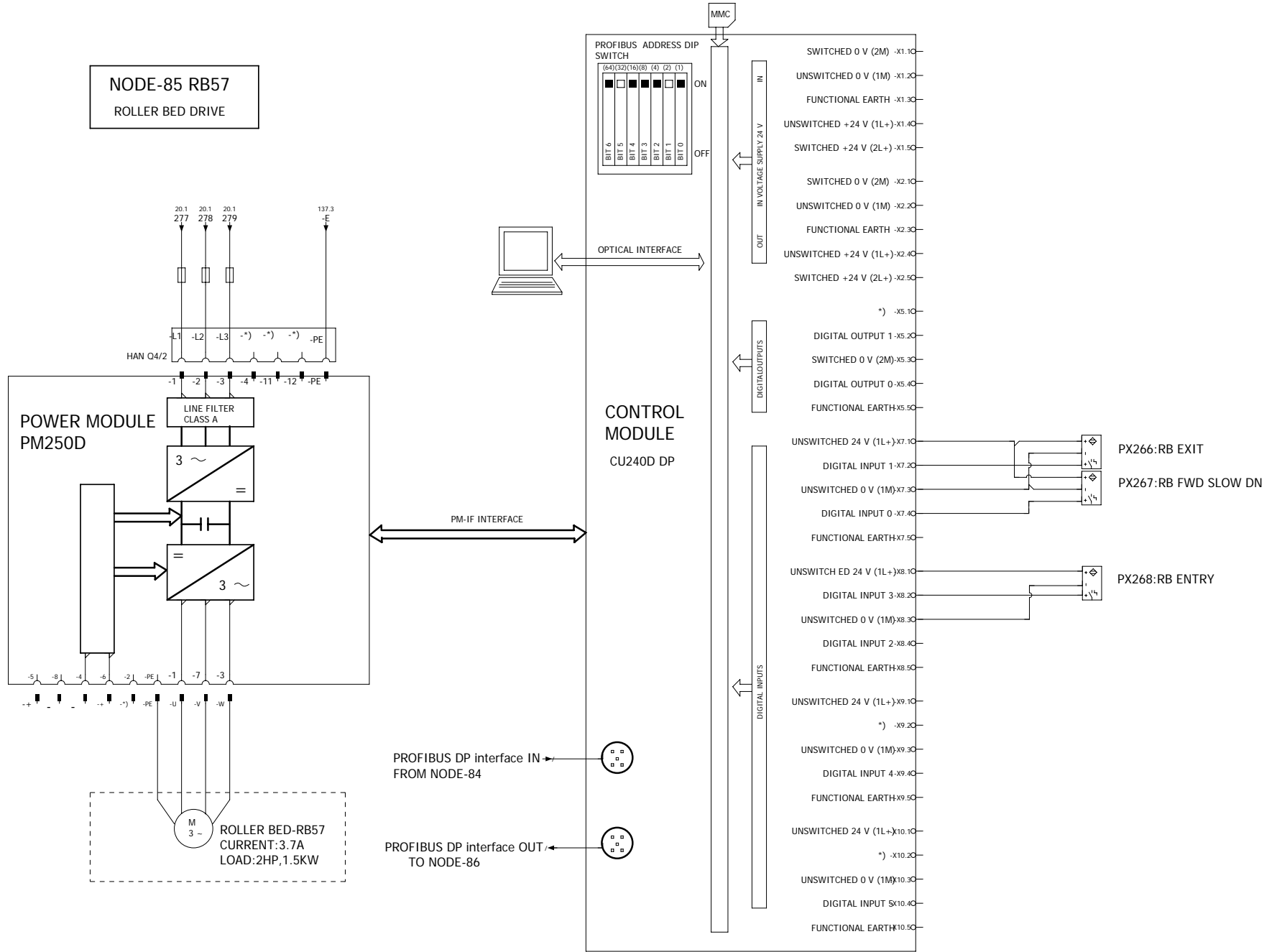

DOCUMENT ID : CY/DD/R/07
REV : 00

| | | |
|----------|------|--------|
| Drawn | Date | Name |
| Checked | | SHITAL |
| Approved | | |

| | |
|---------------------|---------|
| PROJECT DESCRIPTION | TITLE |
| HA-382 VOLVO FRANCE | NODE-85 |

| | |
|-------------------|--------|
| PROJECT CODE :- | HA-382 |
| DRAWING NUMBER :- | |

NODE-86 RB58
ROLLER BED DRIVE

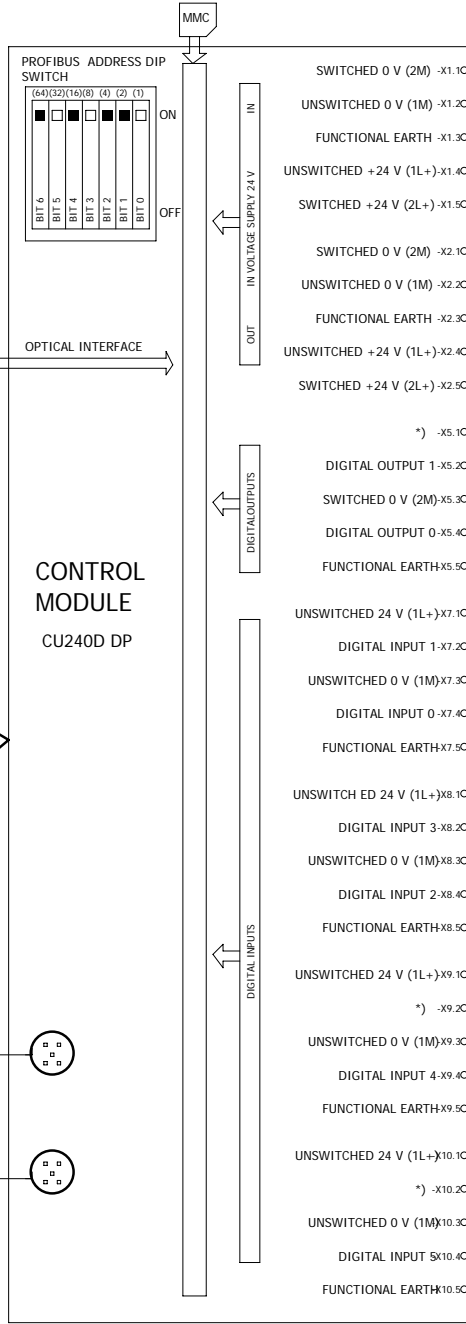
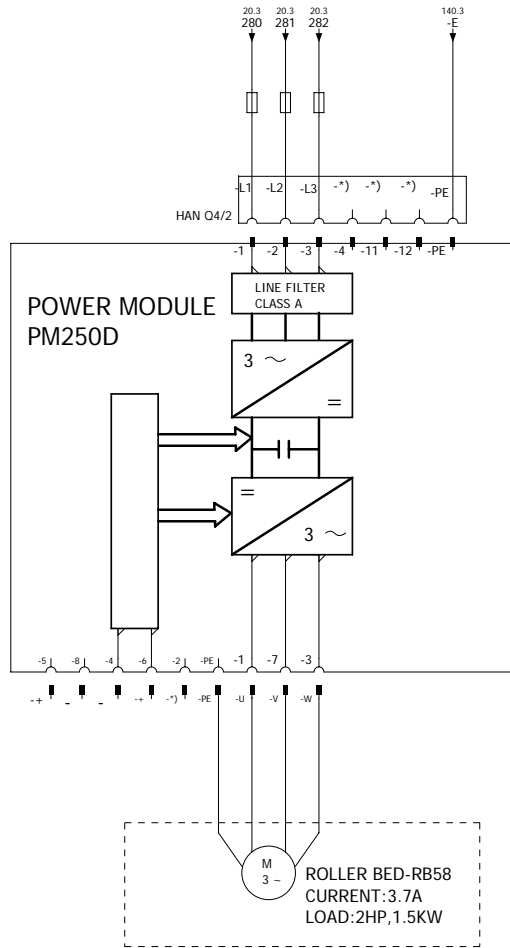

PROFIBUS DP interface IN FROM NODE-85

PROFIBUS DP interface OUT TO NODE-87

DOCUMENT ID : CY/DD/R/07

REV : 00

CYBERNETIK TECHNOLOGIES PVT.LTD, PUNE

| | | |
|----------|------|--------|
| Drawn | Date | Name |
| Checked | | SHITAL |
| Approved | | |

PROJECT DESCRIPTION
HA-382 VOLVO FRANCE

TITLE
NODE-86

| | |
|--------------------------|---------------|
| PROJECT CODE :- | HA-382 |
| DRAWING NUMBER :- | |
| Page | 139 |
| Pages | 147 |

NODE-87 RB59
ROLLER BED DRIVE

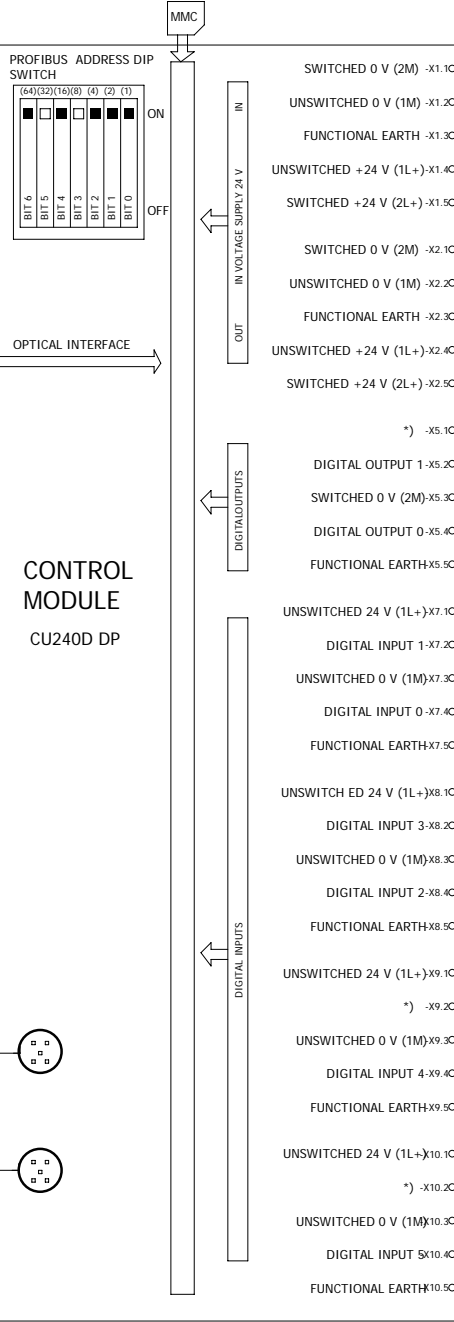
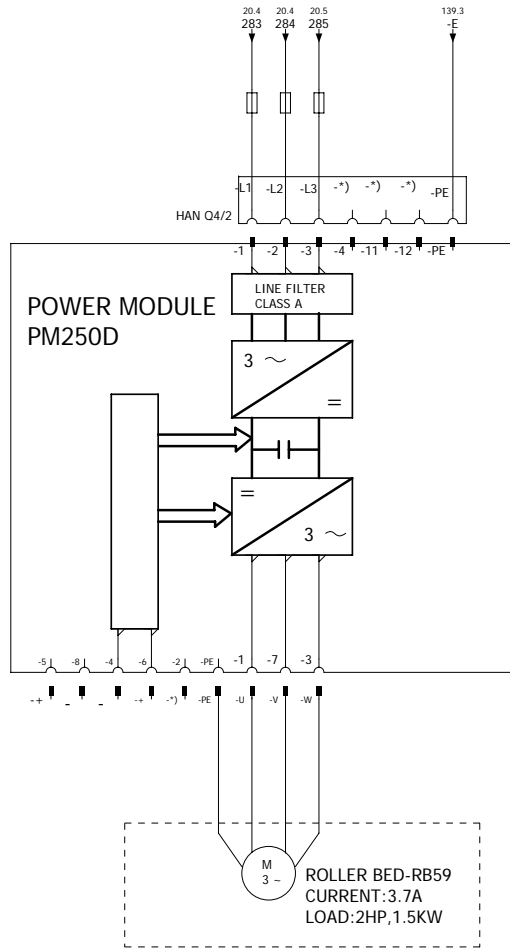

PROFIBUS DP interface IN FROM NODE-86

PROFIBUS DP interface OUT TO NODE-88

PX272:RB EXIT

PX273:RB FWD SLOW DN

PX274:RB ENTRY

| | |
|----------|--------|
| DATE | NAME |
| | SHITAL |
| CHECKED | |
| APPROVED | |

| |
|---------------------|
| PROJECT DESCRIPTION |
| HA-382 VOLVO FRANCE |

| |
|---------|
| TITLE |
| NODE-87 |

| | |
|-------------------|---------------|
| PROJECT CODE :- | HA-382 |
| DRAWING NUMBER :- | |
| Page | 140 |
| Pages | 147 |

NODE-88 RBTS07-A
ROLLER BED DRIVE

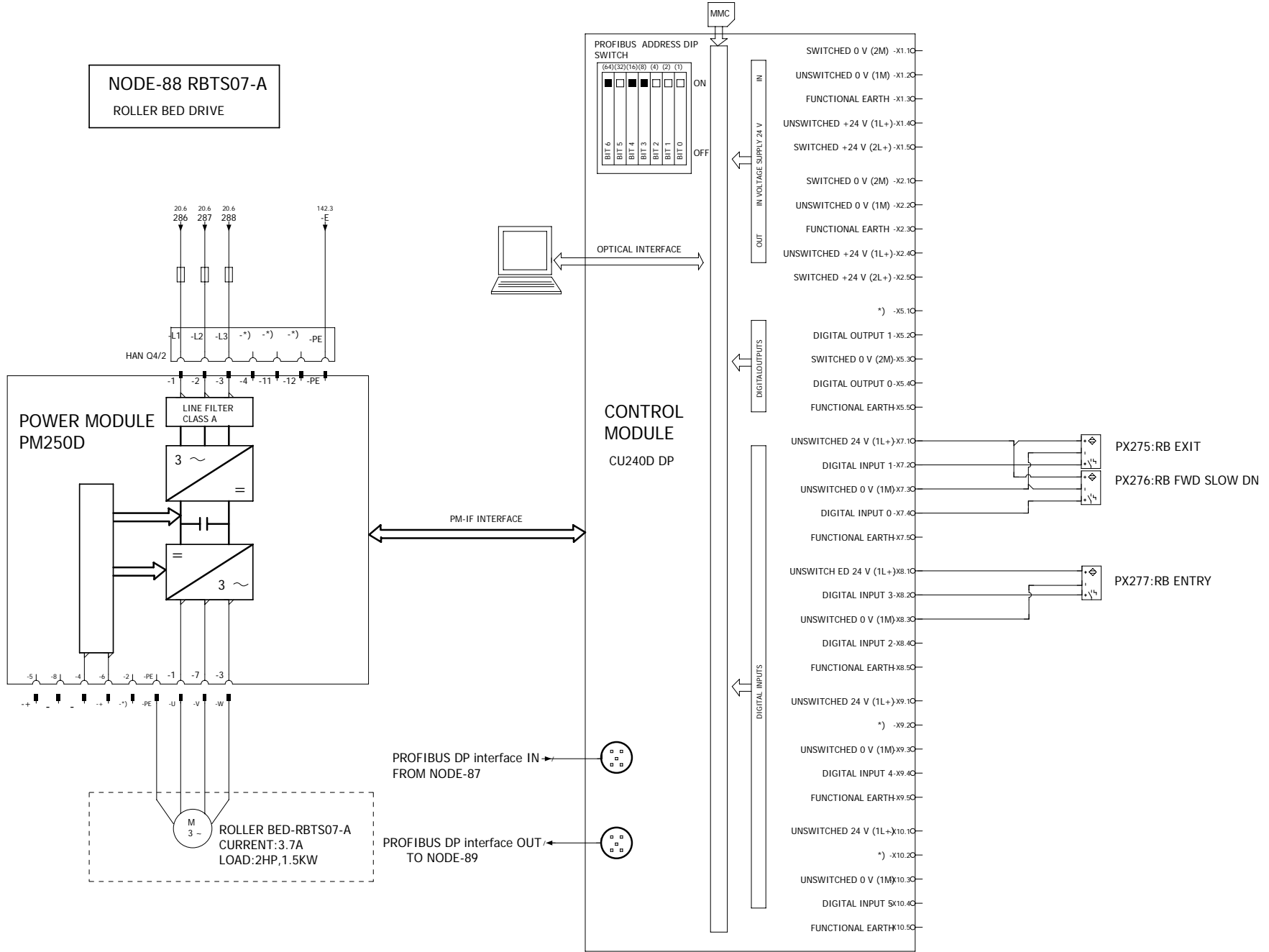

DOCUMENT ID : CY/DD/R/07
REV : 00

| | | |
|----------|------|--------|
| Drawn | Date | Name |
| Checked | | SHITAL |
| Approved | | |

| | |
|---------------------|---------|
| PROJECT DESCRIPTION | TITLE |
| HA-382 VOLVO FRANCE | NODE-88 |

| | |
|-------------------|--------|
| PROJECT CODE :- | HA-382 |
| DRAWING NUMBER :- | |

NODE-89 RBTS07-B
TRANSFER CAR DRIVE

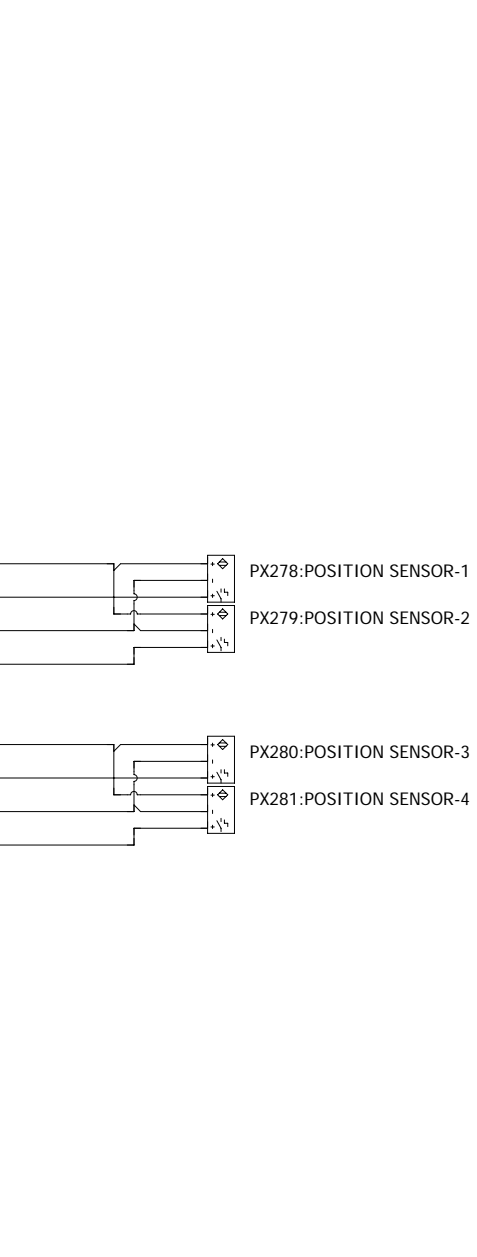
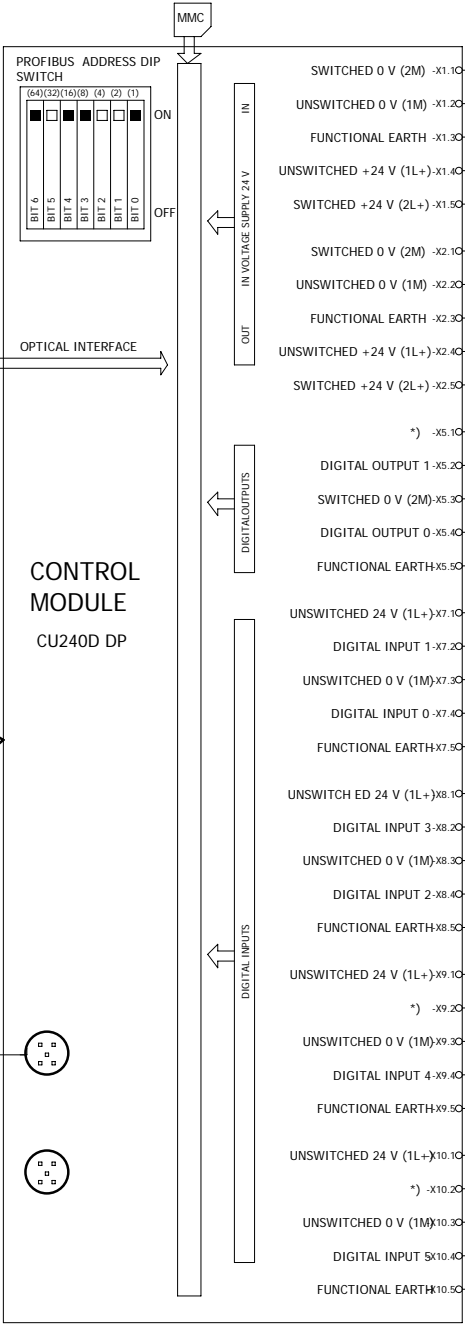
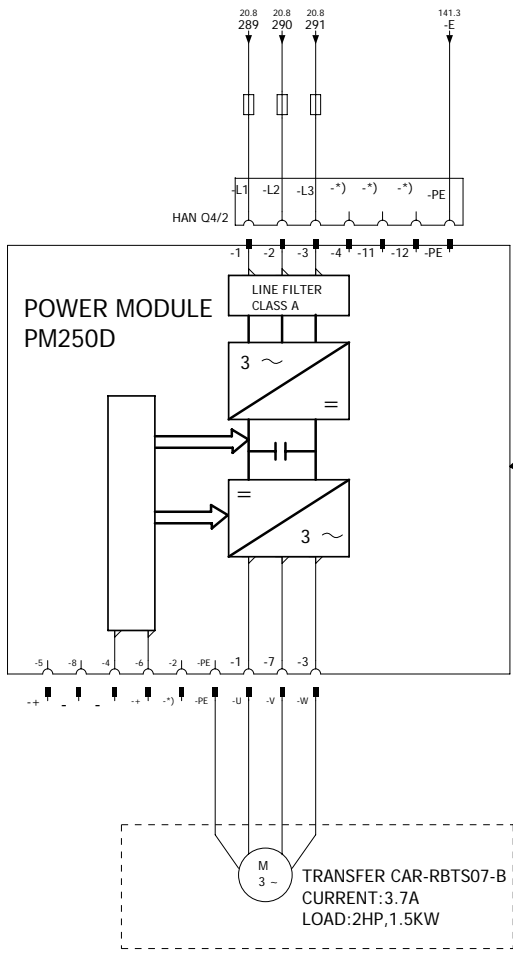

DOCUMENT ID : CY/DD/R/07
REV : 00

CYBERNETIK TECHNOLOGIES PVT.LTD, PUNE

| | Date | Name |
|----------|------|--------|
| DRAWN | | SHITAL |
| CHECKED | | |
| APPROVED | | |

PROJECT DESCRIPTION
HA-382 VOLVO FRANCE

TITLE
NODE-89

| | |
|-------------------|---------------|
| PROJECT CODE :- | HA-382 |
| DRAWING NUMBER :- | |
| Page | 142 |
| Pages | 147 |

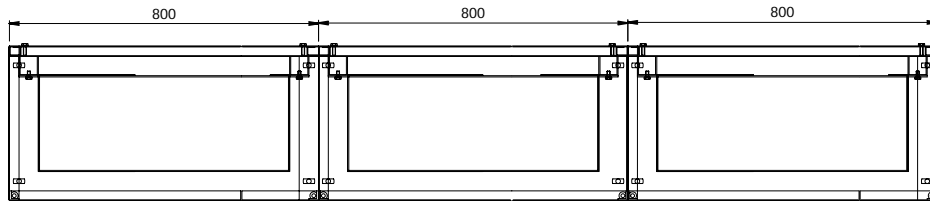

CONTROL PANEL
 MATERIAL MS 2 MM THK
 QTY : 1 NO.
 POWDER COAT : RAL 7035

PLAN

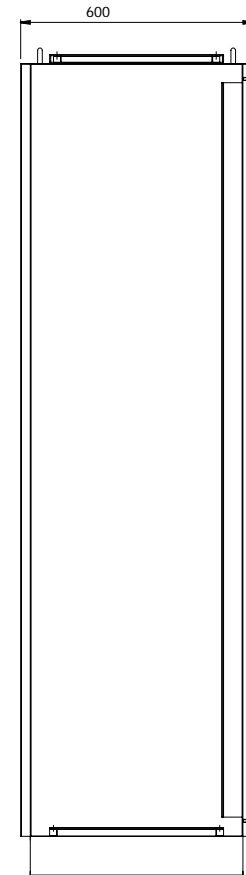
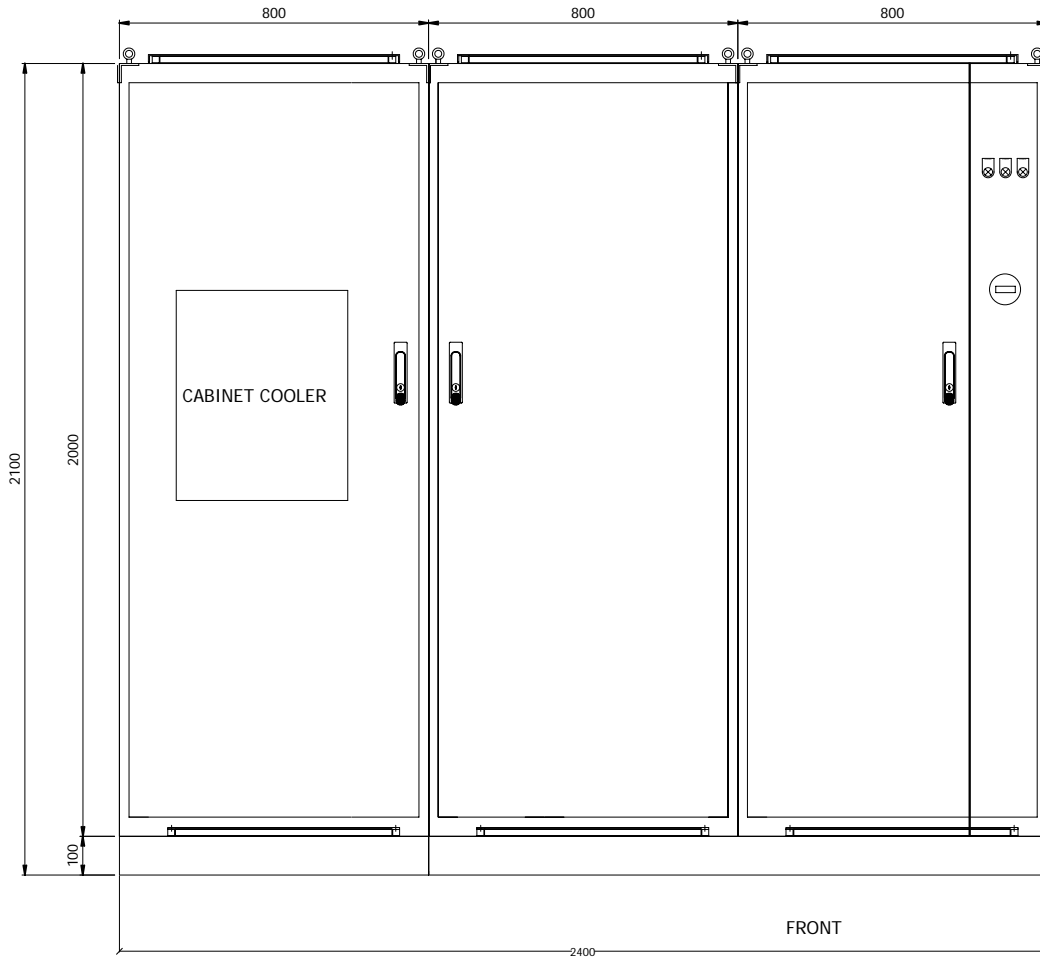

SIDE VIEW

DOCUMENT ID : CY/DD/R/07
 REV : 00



CYBERNETIK TECHNOLOGIES
 PVT.LTD, PUNE

| | |
|----------|--------|
| DATE | NAME |
| | SHITAL |
| CHECKED | |
| APPROVED | |

| |
|---------------------|
| PROJECT DESCRIPTION |
| HA-382 VOLVO FRANCE |

| |
|--------------|
| TITLE |
| PANEL LAYOUT |

| | |
|-------------------|--------|
| PROJECT CODE:- | HA-382 |
| DRAWING NUMBER :- | |
| Page | 143 |
| Pages | 147 |

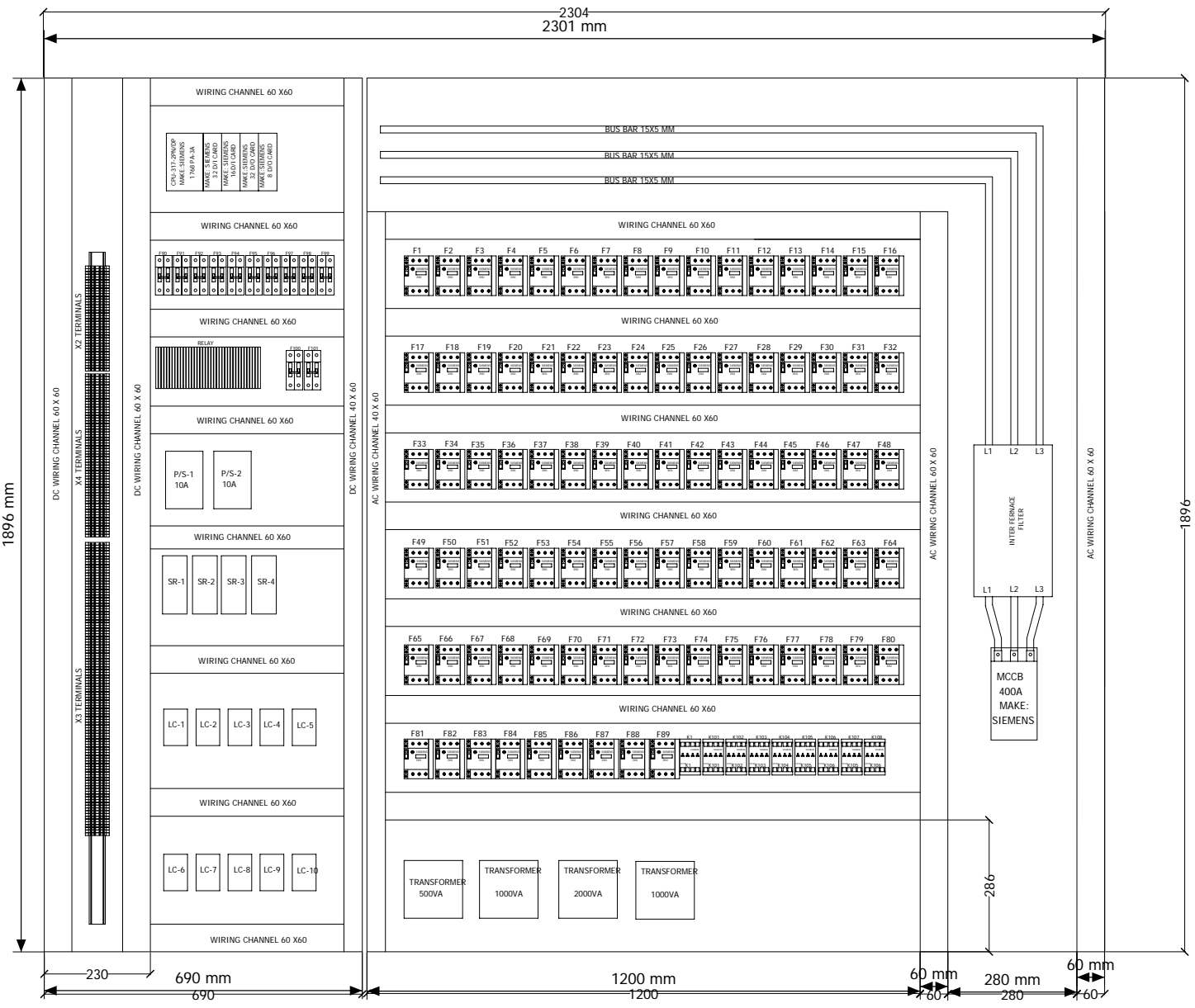

DOCUMENT ID : CY/DD/R/07
REV : 00

CYBERNETIK TECHNOLOGIES
PVT.LTD, PUNE

| | | |
|----------|------|--------|
| Drawn | Date | Name |
| Checked | | SHITAL |
| Approved | | |

| | |
|---------------------|-----------------------|
| PROJECT DESCRIPTION | TITLE |
| HA-382 VOLVO FRANCE | INTERNAL PANEL LAYOUT |

| | |
|-------------------|--------|
| PROJECT CODE :- | HA-382 |
| DRAWING NUMBER :- | |
| Page | 144 |
| Pages | 147 |