

Direct Duct Mount Kit for PointWatch Eclipse

DESCRIPTION

The Direct Duct Mount Kit enables the Model PIRECL PointWatch Eclipse to detect combustible hydrocarbon gases within air handling ductwork. The kit provides the hardware necessary to mount the PointWatch Eclipse directly to the duct wall, eliminating the need for extractive vacuum pumps or aspirators. When used with the Direct Duct Mount kit, the PointWatch Eclipse utilizes the standard, three-layer weather protection baffle to protect its optics from contaminants. A test gas hose with a self-sealing, quick-connect external hose fitting enables response testing without removing the detector from the duct.

The Direct Duct Mount kit provides all necessary detector mounting hardware, but does not include the PIRECL PointWatch Eclipse detector (purchased separately). It is suitable for installation in most duct applications, but is not recommended for use in extremely hot and/or dirty applications. The Direct Duct Mount kit provides optimum protection when used in addition to a properly installed open area gas detection system.

SPECIFICATIONS

MATERIALS—

Assembly:	Stainless Steel (p/n 007525-003) Aluminum (p/n 007525-004).
Plate Seal Gasket:	Closed cell rubber.
Test Gas Hose:	Clear PVC (vinyl) tubing.

OPERATING TEMPERATURE RANGE—

-40°C to +75°C (-40°F to +167°F).

DIMENSIONS—

See Figure 1.

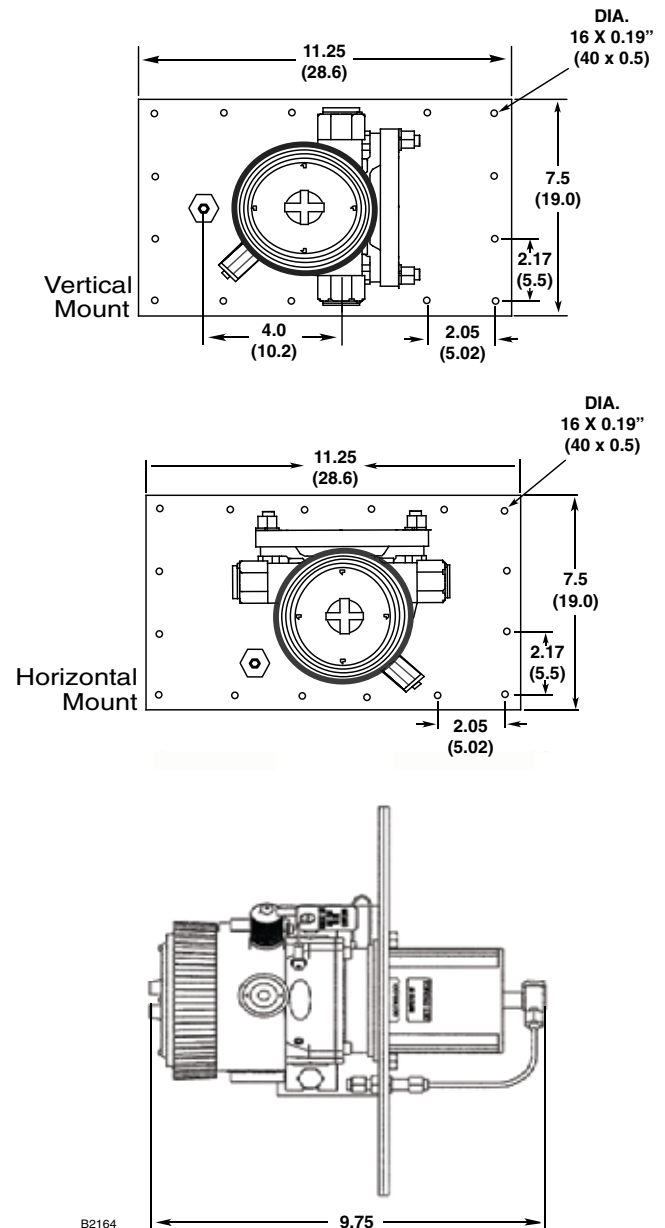

Figure 1—Duct Mount Dimensions in Inches

Detector Electronics Corporation

6901 West 110th Street • Minneapolis, Minnesota 55438 • Operator (952) 941-5665 or (800) 765-FIRE
Customer Service (952) 946-6491 • Fax (952) 829-8750 • www.det-tronics.com • E-mail: det-tronics@det-tronics.com